

CLASS

INTRODUCTION AND BASIC CONCEPTS

Copyright © The McGraw-Hill Companies, Inc. Permission required for reproduction or display.

Objectives

- Identify the unique vocabulary associated with thermofluids through the precise definition of basic concepts to form a sound foundation for the development of the principles of thermofluids.
- Explain the basic concepts of thermofluids.
- Review concepts of temperature, temperature scales, pressure, and absolute and gage pressure.

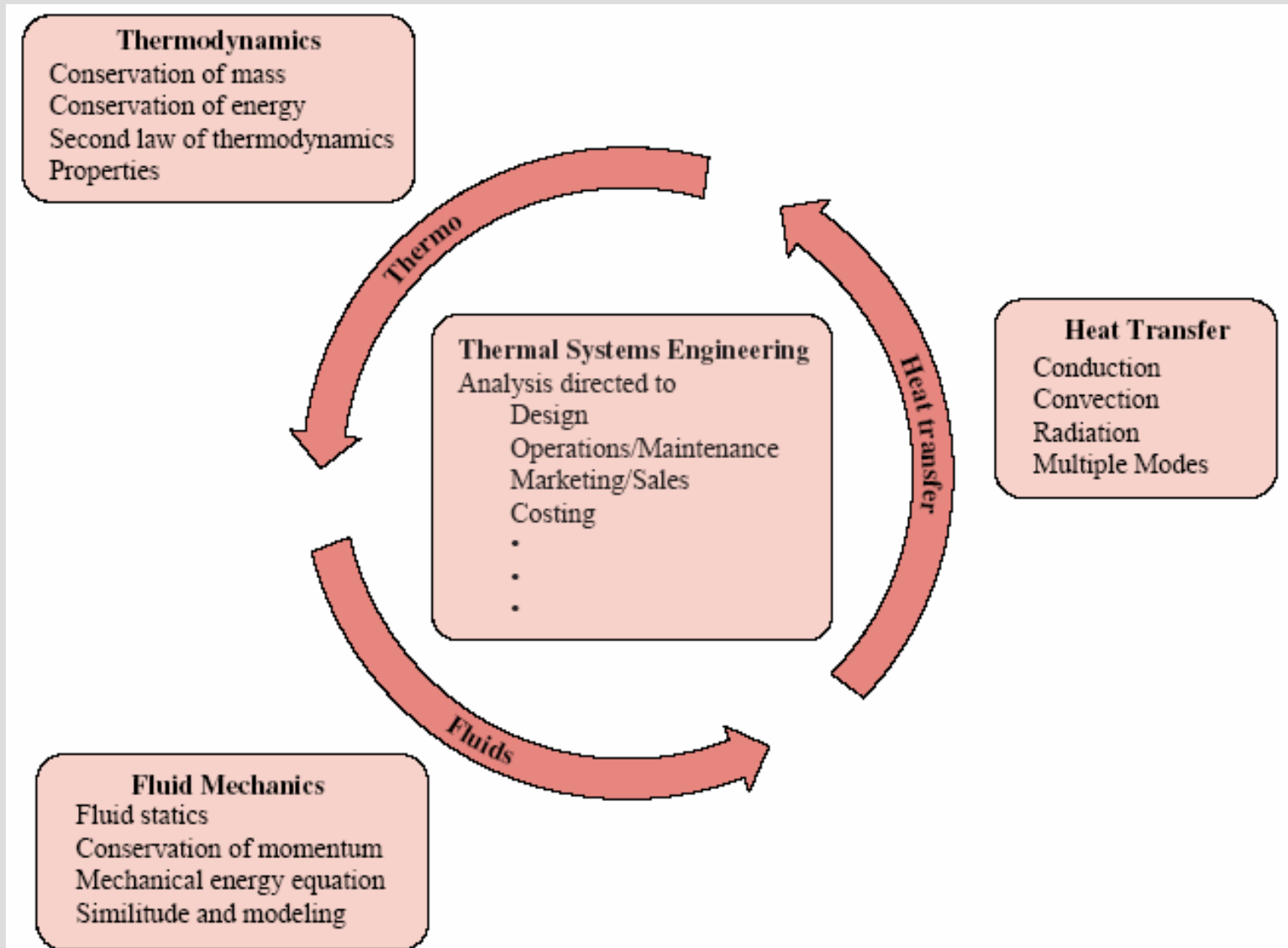

Figure 1.5 The disciplines of thermodynamics, fluid mechanics, and heat transfer involve fundamentals and principles essential for the practice of thermal systems engineering.

FIGURE 1-5

Some application areas of thermodynamics.

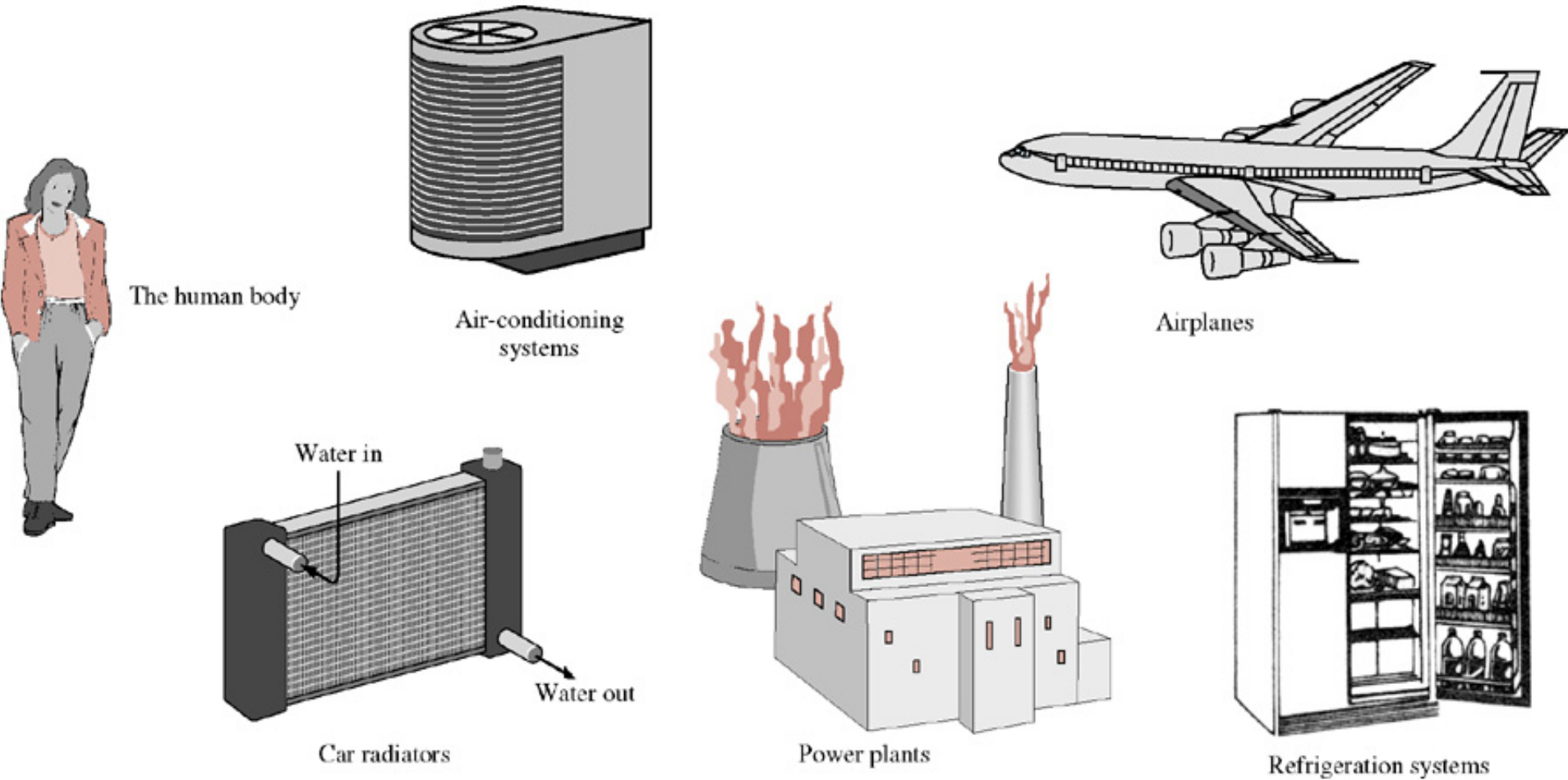
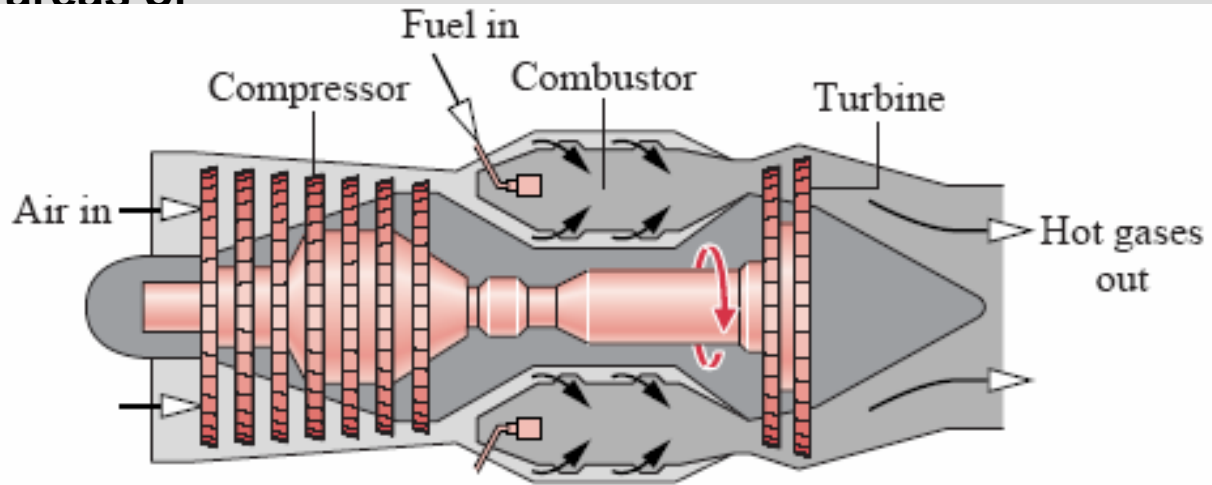
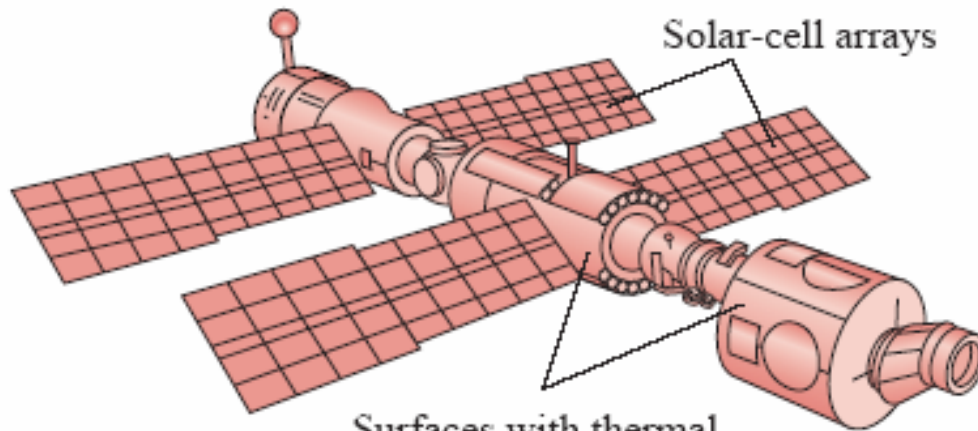

FIGURE 1-5

Some application areas of thermodynamics.



Turbojet engine



Surfaces with thermal control coatings
International Space Station

FIGURE 1-5

Some application areas of thermodynamics.

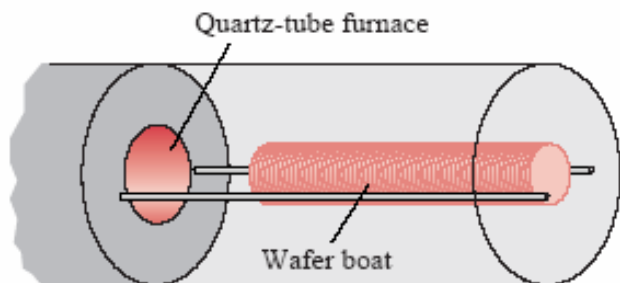

High-temperature annealing of silicon wafers

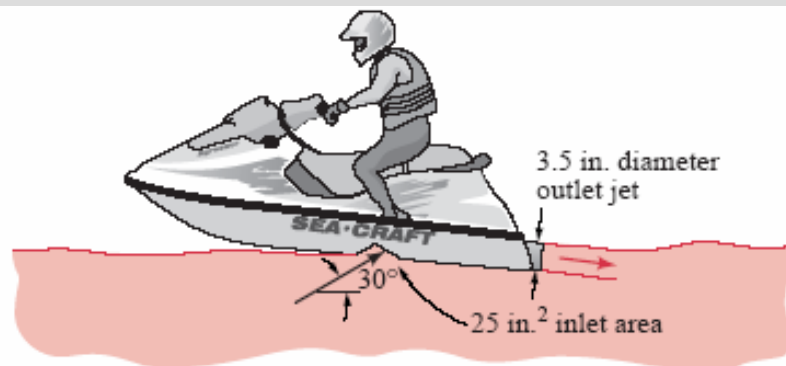

Jet ski water =-pump propulsion

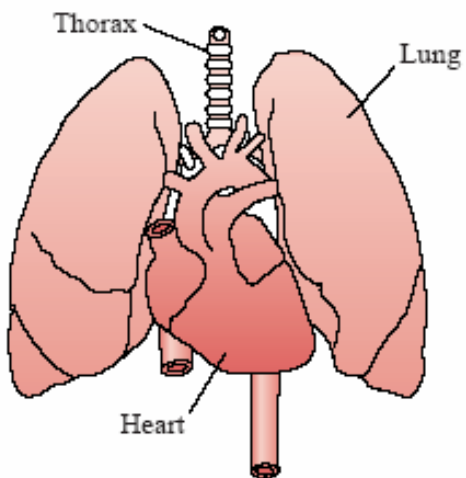

Human cardiovascular system

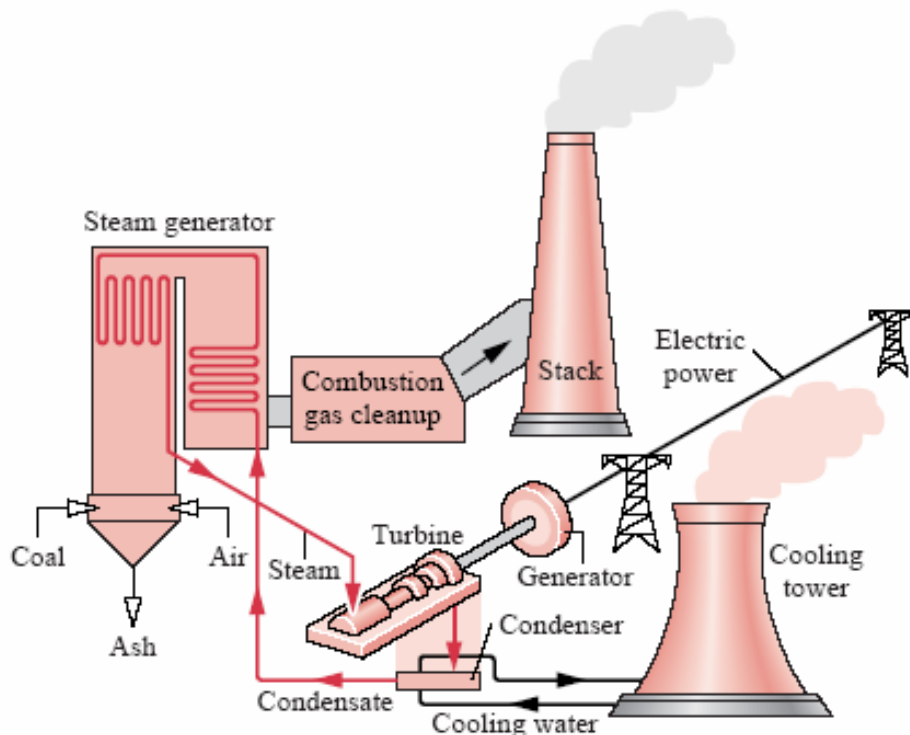

FIGURE 1-5
Some application areas of
thermodynamics.

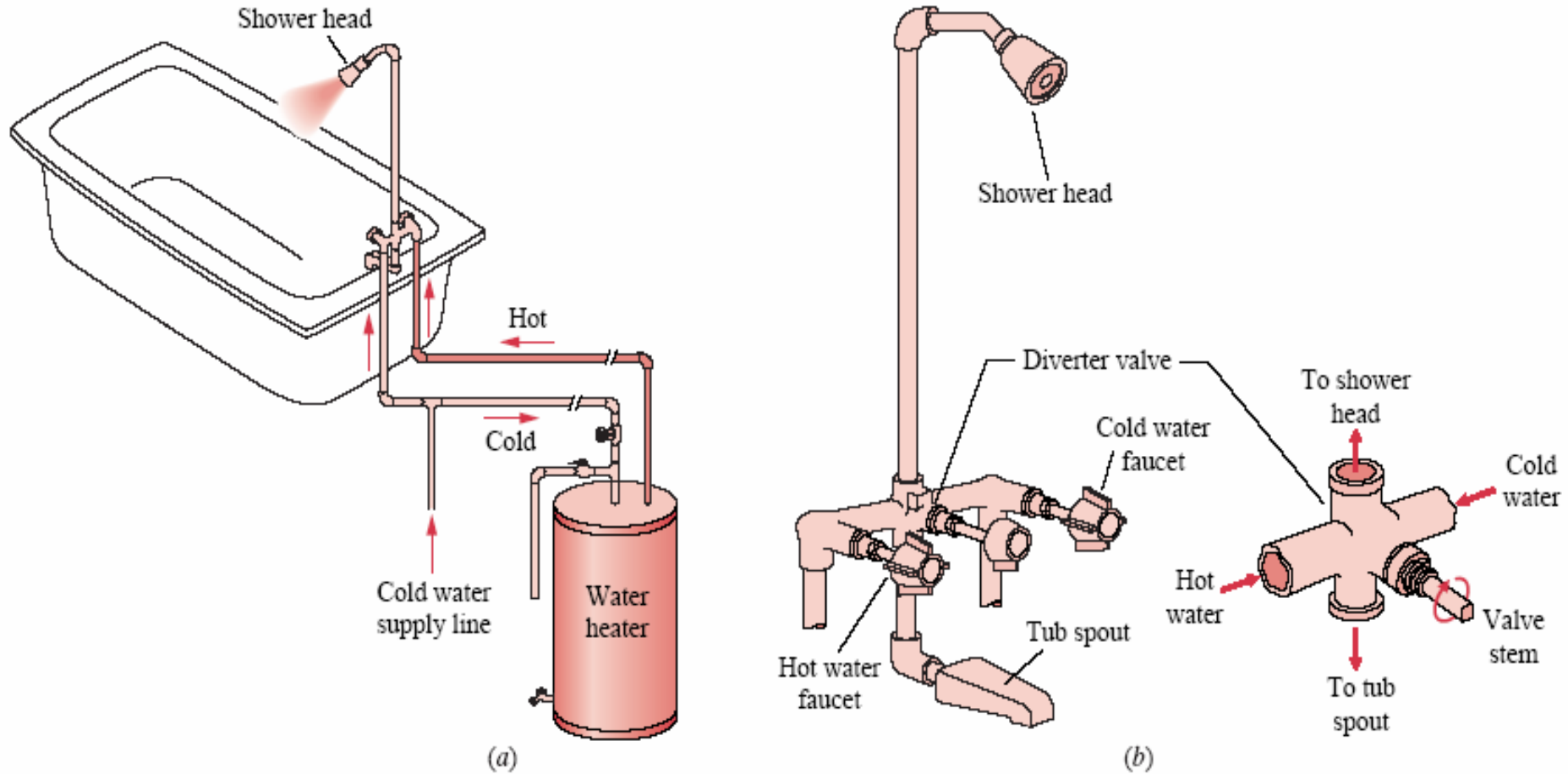

Figure 1.2 Home hot water supply. (a) Overview. (b) Faucet and shower head.

FIGURE 1–5

Some application areas of Fluid Mechanics

- ✓ **Aerodynamics**
- ✓ **Bioengineering and biological systems**
- ✓ **Combustion**
- ✓ **Energy generation**
- ✓ **Geology**
- ✓ **Hydraulics and Hydrology**
- ✓ **Hydrodynamics**
- ✓ **Meteorology**
- ✓ **Ocean and Coastal Engineering**
- ✓ **Water Resources**
- ✓ **...numerous other examples...**

Fluid Mechanics is beautiful

Some application areas of Fluid Mechanics, Aerodynamics



Some application areas of Fluid Mechanics, Bioengineering

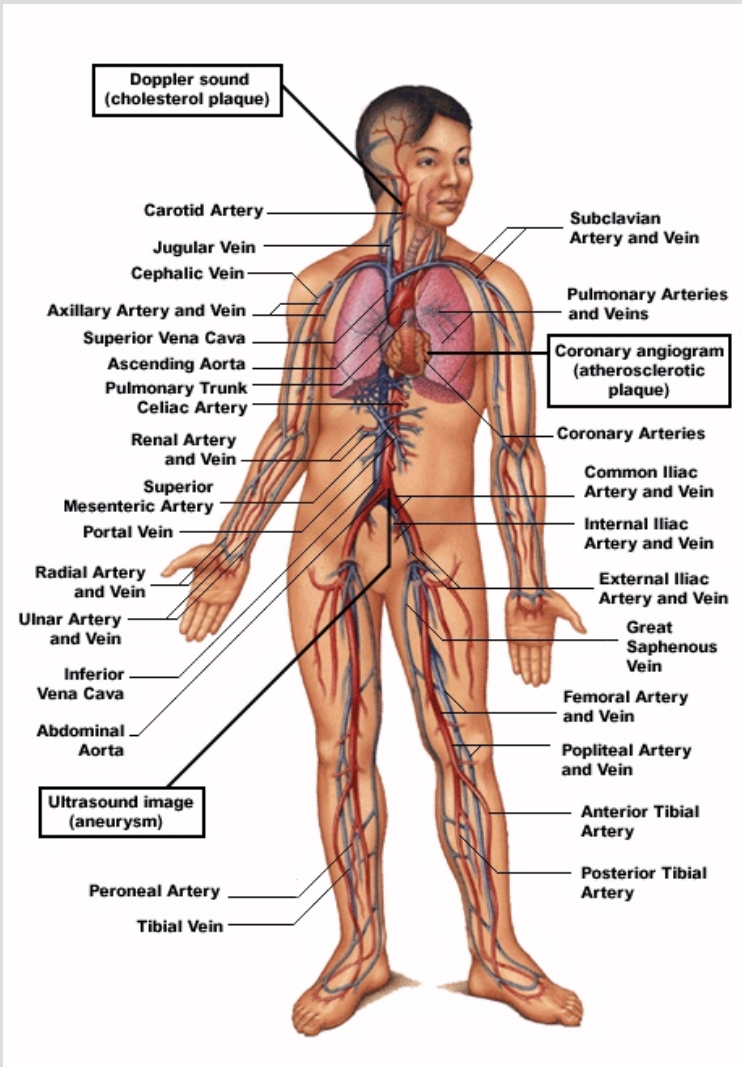

Some application areas of Fluid Mechanics, Energy generation



Some application areas of Fluid Mechanics,



Some application areas of Fluid Mechanics, Geology



Some application areas of Fluid Mechanics, River Hydraulics



Some application areas of Fluid Mechanics, Hydraulic Structures



Some application areas of Fluid Mechanics, Hydrodynamics



Some application areas of Fluid Mechanics, Meteorology

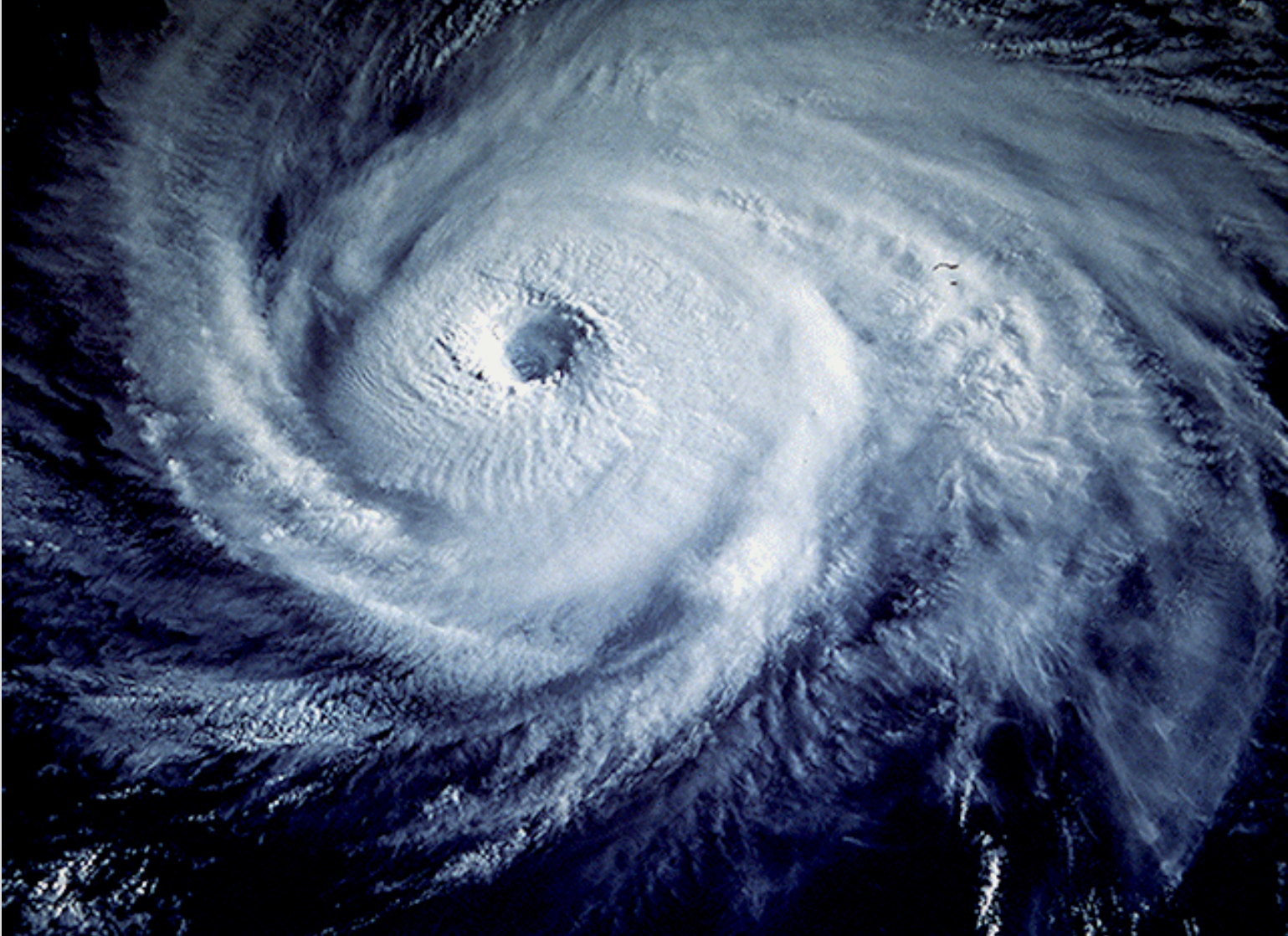

Some application areas of Fluid Mechanics, Fluid Mechanics is beautiful

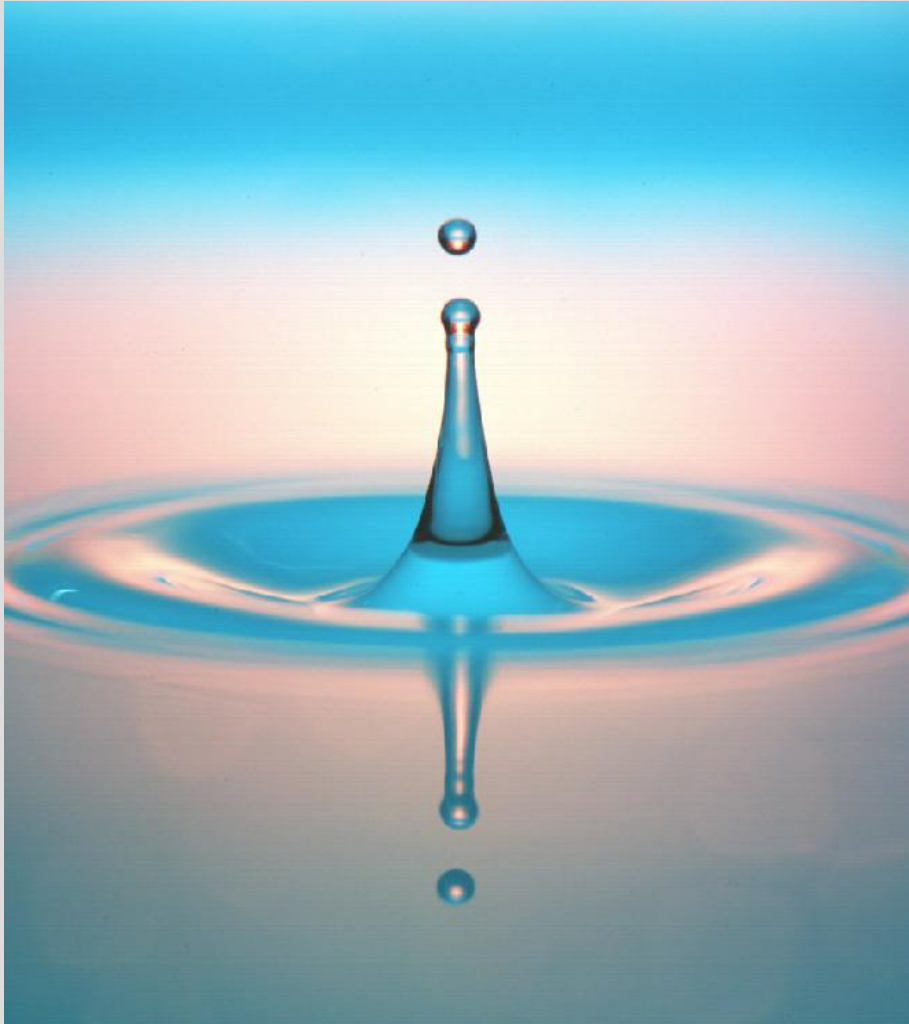

Dimensions and Units

- Any physical quantity can be characterized by **dimensions**.
- The magnitudes assigned to dimensions are called **units**.
- Primary dimensions include: mass m , length L , time t , and temperature T .
- Secondary dimensions can be expressed in terms of primary dimensions and include: velocity V , energy E , and volume V .
- Unit systems include English system and the metric SI (International System). We'll use both.
- **Dimensional homogeneity** is a valuable tool in checking for errors. Make sure every term in an equation has the same units.
- **Unity conversion ratios** are helpful in converting units. Use them.

Dimensions and Units

Table 2.1 SI Units for Mass, Length, Time, and Force

Quantity	Unit	Symbol
mass	kilogram	kg
length	meter	m
time	second	s
force	newton (= 1 kg · m/s ²)	N

Table 2.3 Other Units for Mass, Length, Time, and Force

Quantity	Unit	Symbol
mass	pound mass	lb
	slug	slug
length	foot	ft
time	second	s
force	pound force	lbf
	(= 32.1740 lb · ft/s ²)	
	= 1 slug · ft/s ²)	

Table 2.2 SI Unit Prefixes

Factor	Prefix	Symbol
10 ¹²	tera	T
10 ⁹	giga	G
10 ⁶	mega	M
10 ³	kilo	k
10 ²	hecto	h
10 ⁻²	centi	c
10 ⁻³	milli	m
10 ⁻⁶	micro	μ
10 ⁻⁹	nano	n
10 ⁻¹²	pico	p

Accuracy, Precision, and Significant Digits

Engineers must be aware of three principals that govern the proper use of numbers.

- 1. Accuracy error :** Value of one reading minus the true value. Closeness of the average reading to the true value. Generally associated with repeatable, fixed errors.
- 2. Precision error :** Value of one reading minus the average of readings. Is a measure of the fineness of resolution and repeatability of the instrument. Generally associated with random errors.
- 3. Significant digits :** Digits that are relevant and meaningful. When performing calculations, the final result is only as precise as the least precise parameter in the problem. When the number of significant digits is unknown, the accepted standard is 3. Use 3 in all homework and exams.

Accuracy, Precision, and Significant Digits

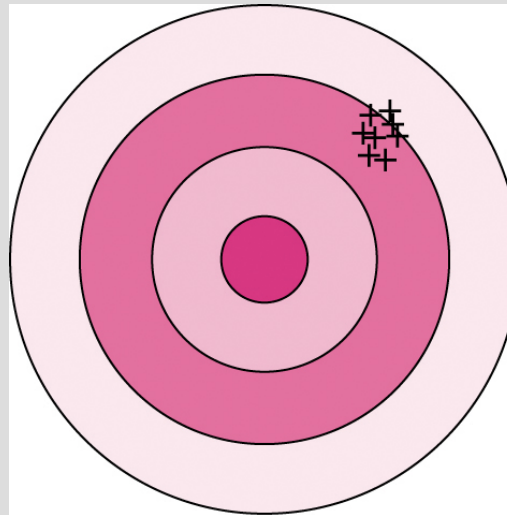

A

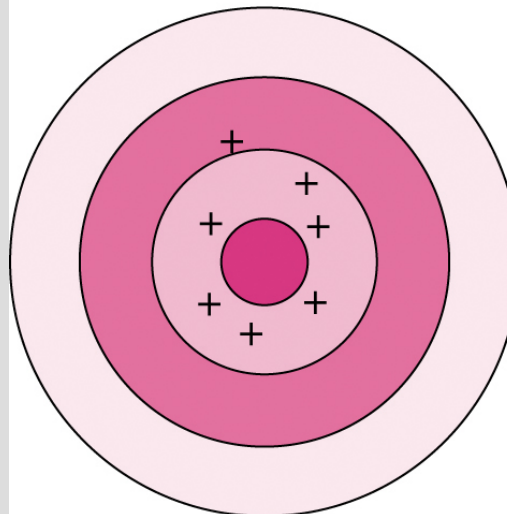

B

SYSTEMS AND CONTROL VOLUMES

- **System:** A quantity of matter or a region in space chosen for study.
- **Surroundings:** The mass or region outside the system
- **Boundary:** The real or imaginary surface that separates the system from its surroundings.
- The boundary of a system can be *fixed* or *movable*.
- Systems may be considered to be *closed* or *open*.

- **Closed system (Control mass):** A fixed amount of mass, and no mass can cross its boundary.

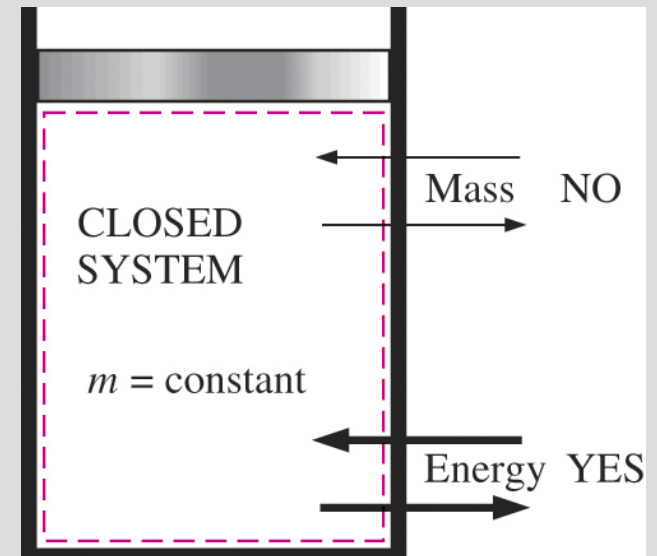
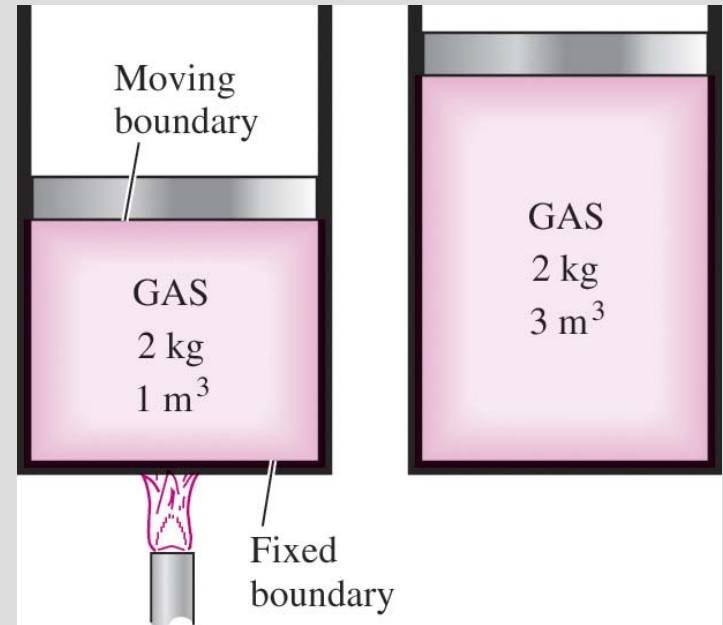
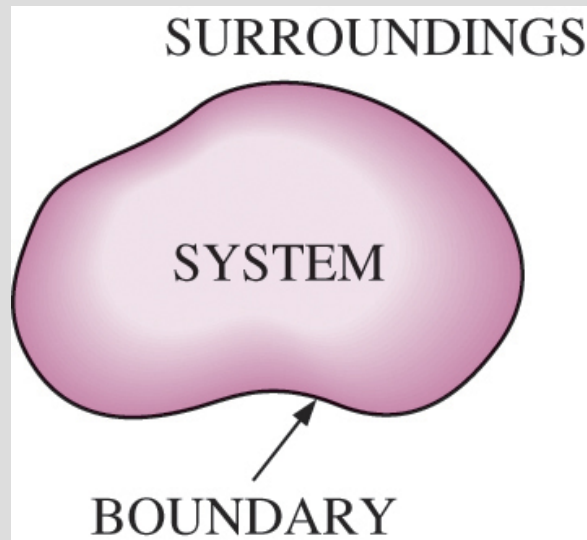

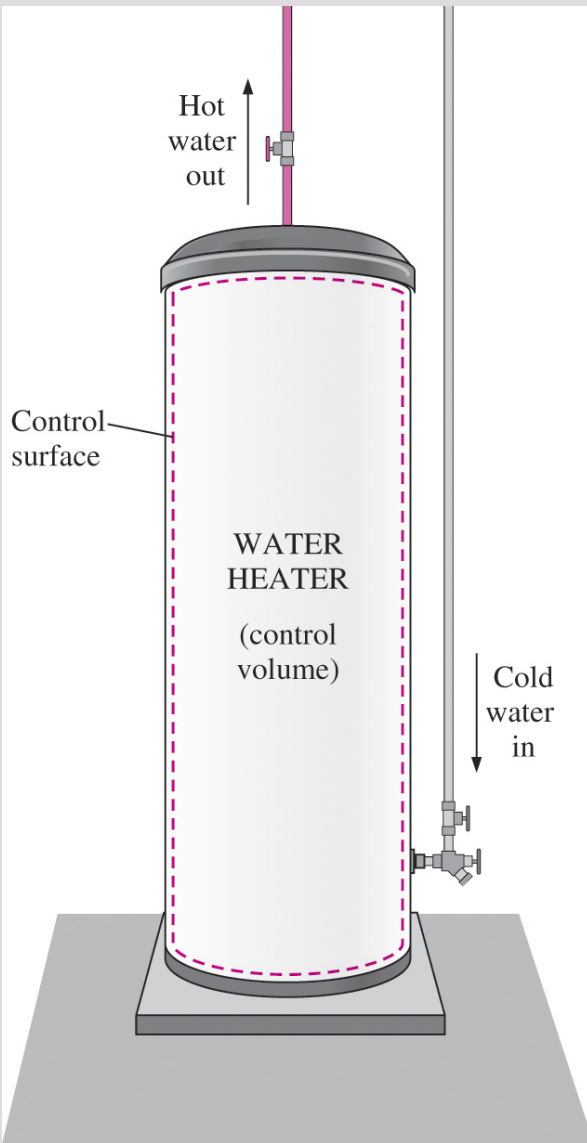

An open system (a control volume) with one inlet and one exit.

- **Open system (control volume):** A properly selected region in space.
- It usually encloses a device that involves mass flow such as a compressor, turbine, or nozzle.
- Both mass and energy can cross the boundary of a control volume.
- **Control surface:** The boundaries of a control volume. It can be real or imaginary.

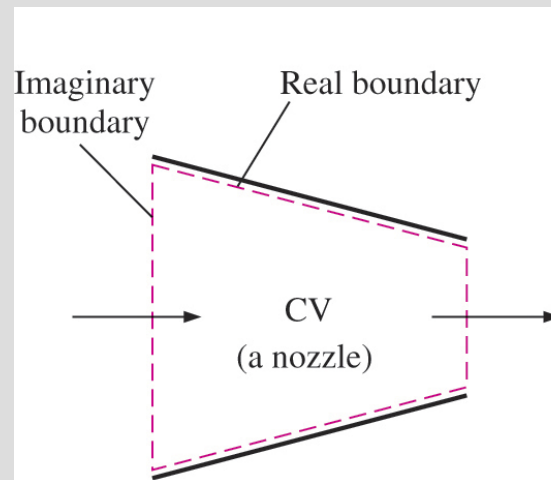

(a) A control volume with real and imaginary boundaries

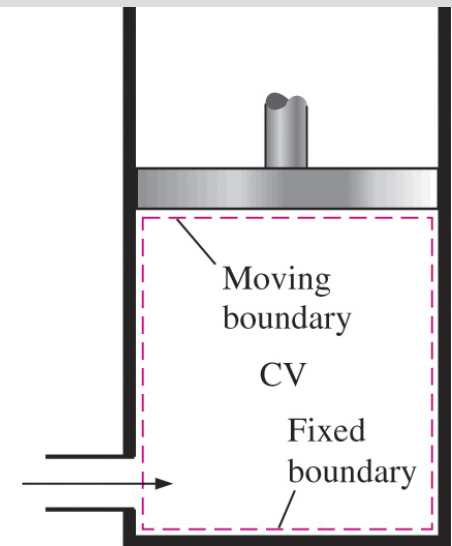

(b) A control volume with fixed and moving boundaries

PROPERTIES OF A SYSTEM

- **Property:** Any characteristic of a system.
- Some familiar properties are pressure P , temperature T , volume V , and mass m .
- Properties are considered to be either *intensive* or *extensive*.
- **Intensive properties:** Those that are independent of the mass of a system, such as temperature, pressure, and density.
- **Extensive properties:** Those whose values depend on the size—or extent—of the system.
- **Specific properties:** Extensive properties per unit mass.

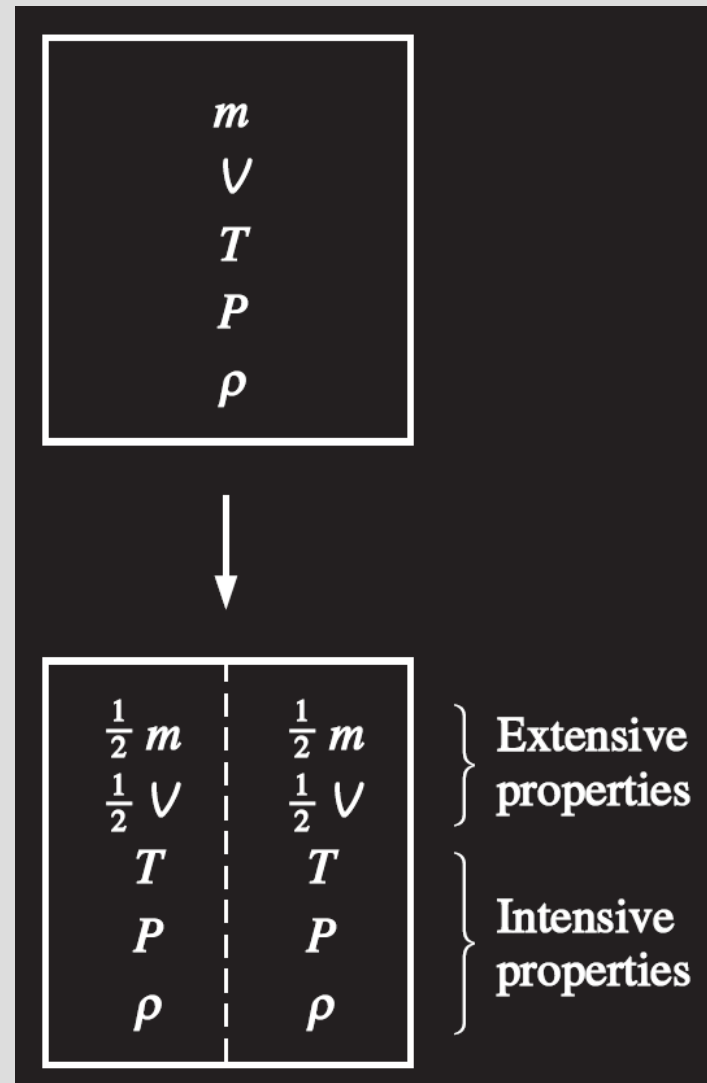

Criterion to differentiate intensive and extensive properties.

Continuum

- Matter is made up of atoms that are widely spaced in the gas phase. Yet it is very convenient to disregard the atomic nature of a substance and view it as a continuous, homogeneous matter with no holes, that is, a **continuum**.
- The continuum idealization allows us to treat properties as point functions and to assume the properties vary continually in space with no jump discontinuities.
- This idealization is valid as long as the size of the system we deal with is large relative to the space between the molecules.
- This is the case in practically all problems.
- In this text we will limit our consideration to substances that can be modeled as a continuum.

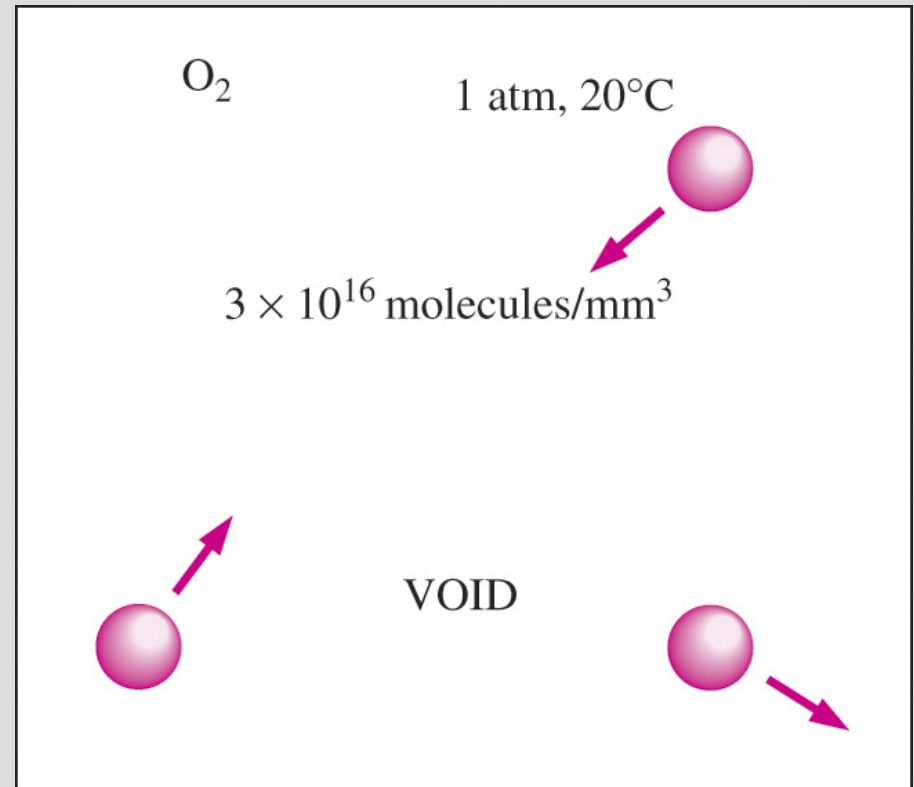

Despite the large gaps between molecules, a substance can be treated as a continuum because of the very large number of molecules even in an extremely small volume.

What is a fluid?

- A fluid is a substance in the gaseous or liquid form
- Distinction between solid and fluid?
 - ✓ Solid: can resist an applied shear by deforming. Stress is proportional to strain
 - ✓ Fluid: deforms continuously under applied shear. Stress is proportional to strain rate

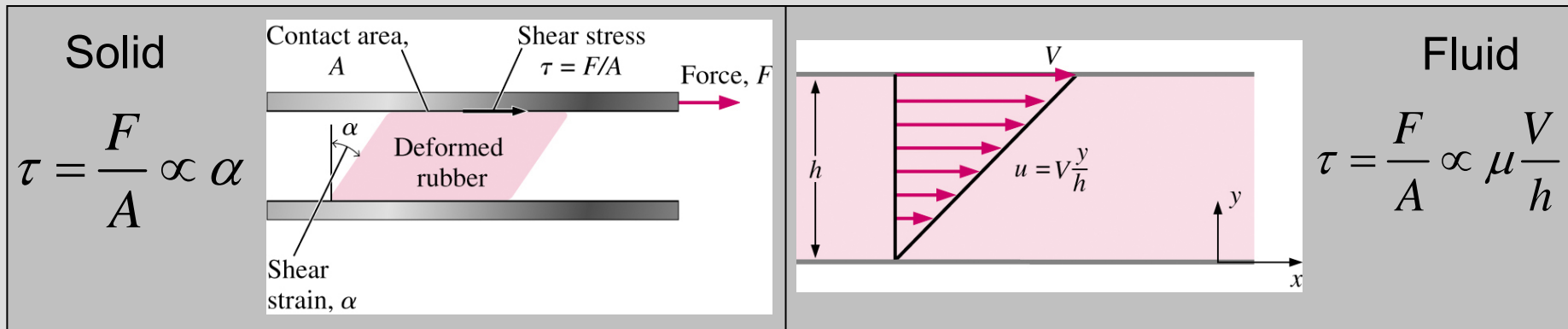

What is a fluid?

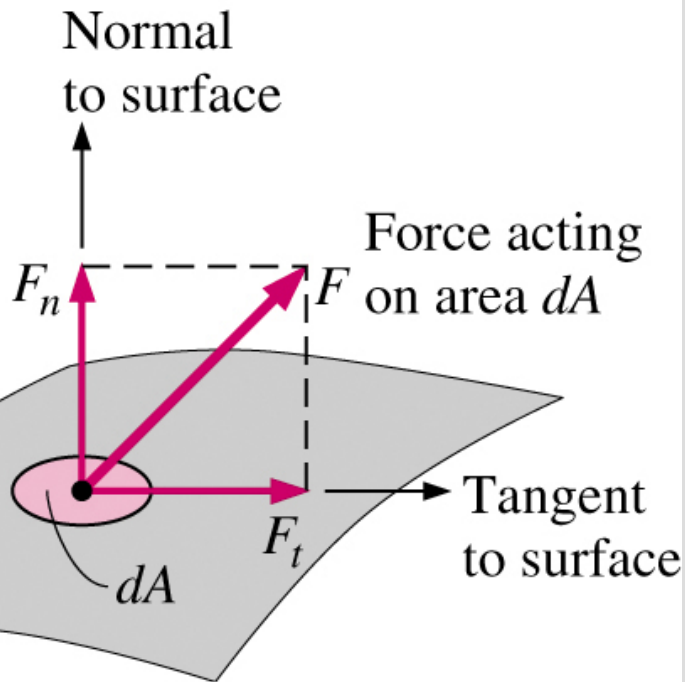

- Stress is defined as the force per unit area.
- Normal component: normal stress
 - ✓ In a fluid at rest, the normal stress is called **pressure**
- Tangential component: shear stress

What is a fluid?

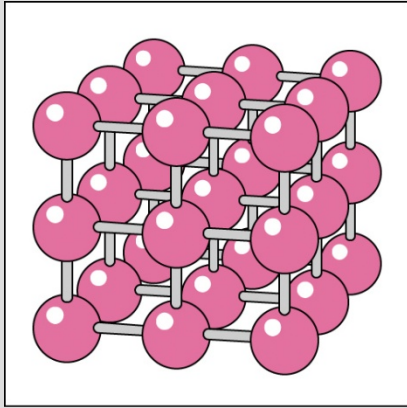

(a)

solid

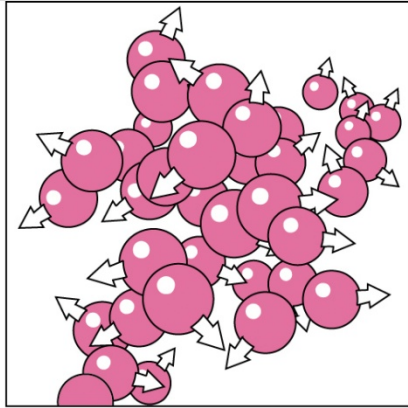

(b)

liquid

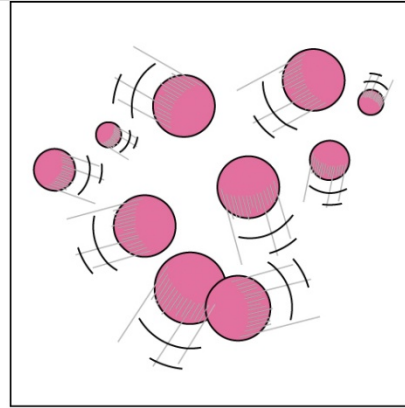

(c)

gas

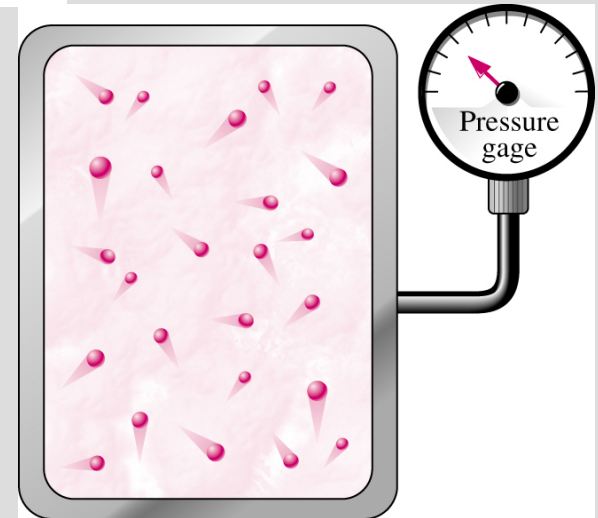

STATE AND EQUILIBRIUM

- Thermodynamics deals with *equilibrium* states.
- **Equilibrium:** A state of balance.
- In an equilibrium state there are no unbalanced potentials (or driving forces) within the system.
- **Thermal equilibrium:** If the temperature is the same throughout the entire system.
- **Mechanical equilibrium:** If there is no change in pressure at any point of the system with time.
- **Phase equilibrium:** If a system involves two phases and when the mass of each phase reaches an equilibrium level and stays there.
- **Chemical equilibrium:** If the chemical composition of a system does not change with time, that is, no chemical reactions occur.

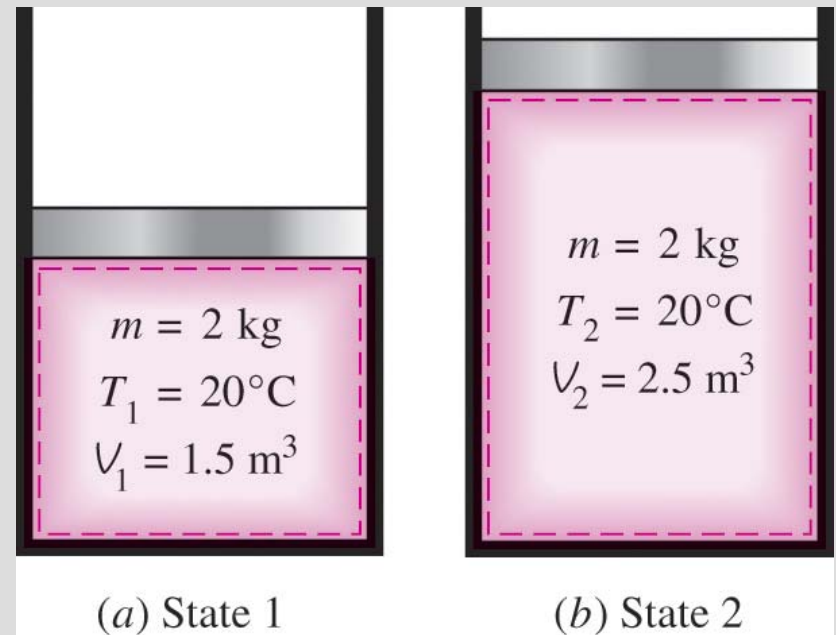

A system at two different states.

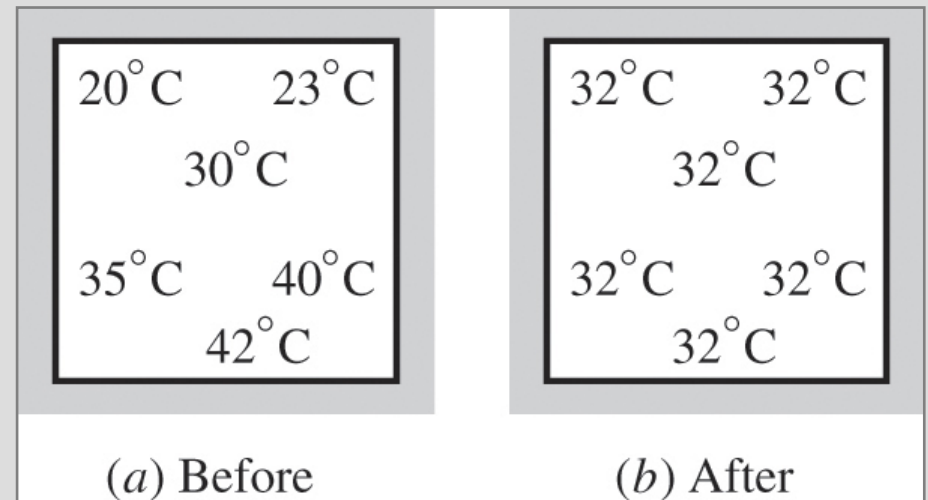

A closed system reaching thermal equilibrium.

The State Postulate

- The number of properties required to fix the state of a system is given by the **state postulate**:
 - ✓ *The state of a simple compressible system is completely specified by two independent, intensive properties.*
- **Simple compressible system**: If a system involves no electrical, magnetic, gravitational, motion, and surface tension effects.



The state of nitrogen is fixed by two independent, intensive properties.

PROCESSES AND CYCLES

Process: Any change that a system undergoes from one equilibrium state to another.

Path: The series of states through which a system passes during a process.

To describe a process completely, one should specify the initial and final states, as well as the path it follows, and the interactions with the surroundings.

Quasistatic or quasi-equilibrium process: When a process proceeds in such a manner that the system remains infinitesimally close to an equilibrium state at all times.

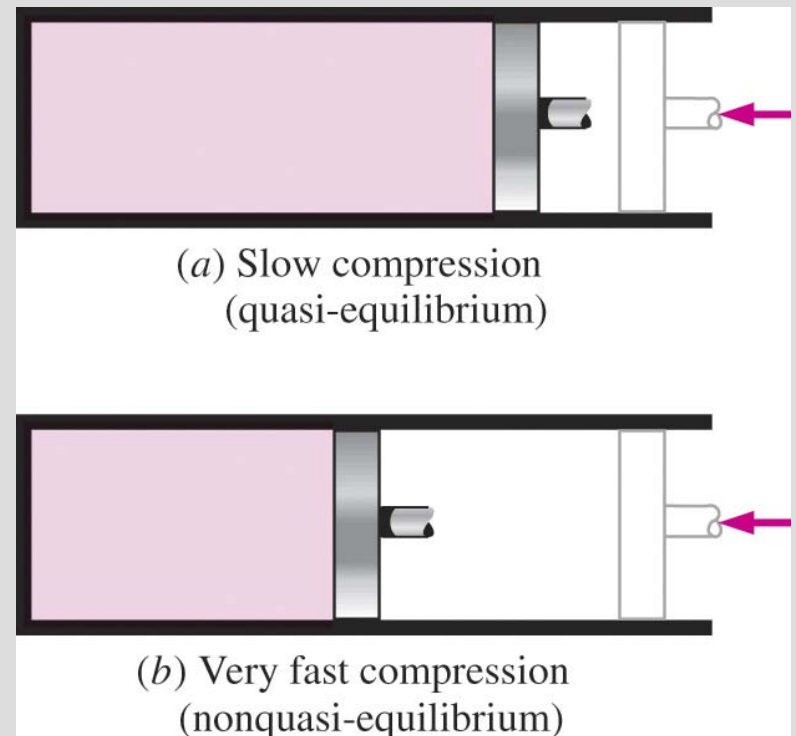
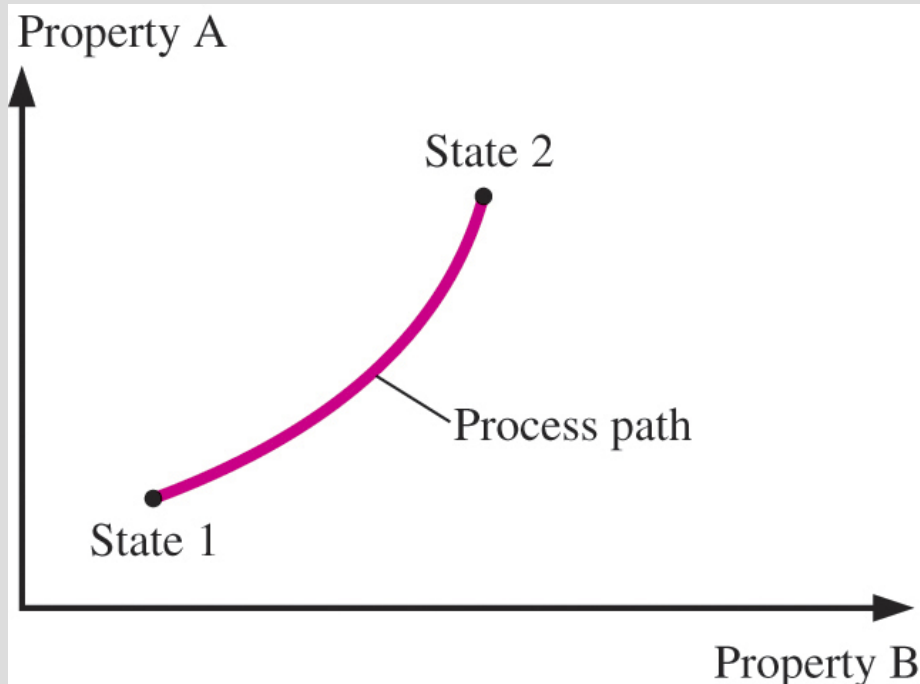

- Process diagrams plotted by employing thermodynamic properties as coordinates are very useful in visualizing the processes.
- Some common properties that are used as coordinates are temperature T , pressure P , and volume V (or specific volume v).
- The prefix *iso-* is often used to designate a process for which a particular property remains constant.
- **Isothermal process:** A process during which the temperature T remains constant.
- **Isobaric process:** A process during which the pressure P remains constant.
- **Isochoric (or isometric) process:** A process during which the specific volume v remains constant.
- **Cycle:** A process during which the initial and final states are identical.

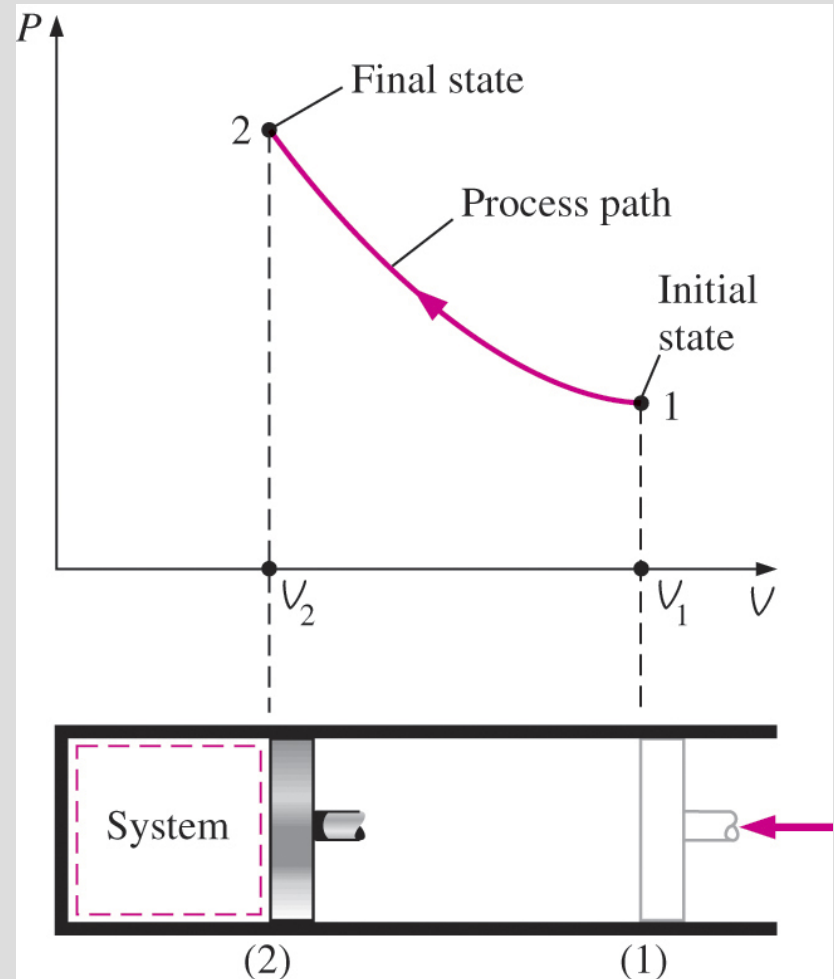

The P - V diagram of a compression process.

The Steady-Flow Process

- The term *steady* implies *no change with time*. The opposite of steady is *unsteady*, or *transient*.
- A large number of engineering devices operate for long periods of time under the same conditions, and they are classified as *steady-flow devices*.
- **Steady-flow process:** A process during which a fluid flows through a control volume steadily.
- Steady-flow conditions can be closely approximated by devices that are intended for continuous operation such as *turbines, pumps, boilers, condensers, and heat exchangers or power plants or refrigeration systems*.

During a steady-flow process, fluid properties within the control volume may change with position but not with time.

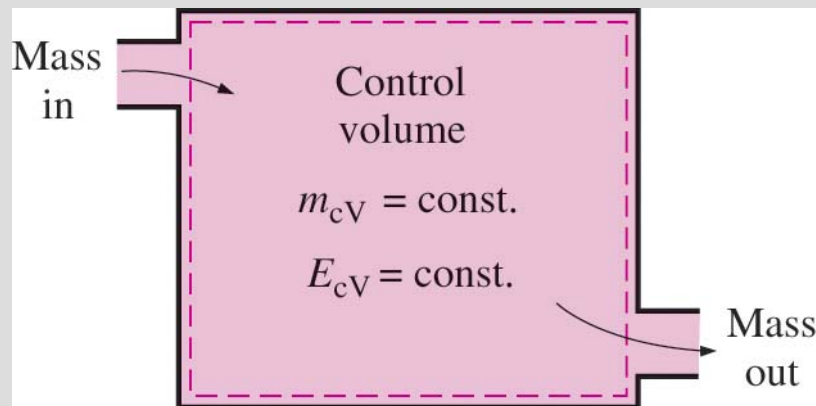
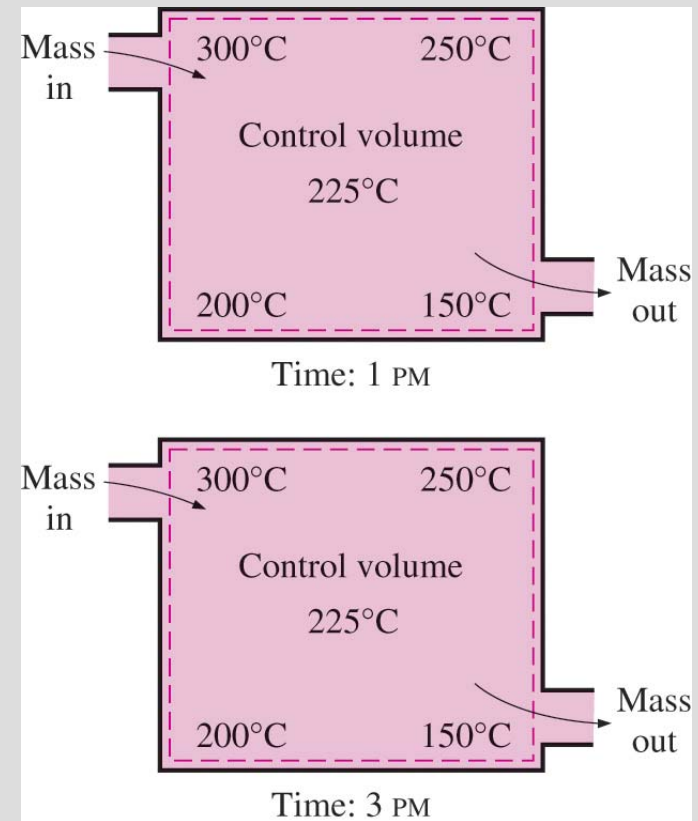

Under steady-flow conditions, the mass and energy contents of a control volume remain constant.

CLASE
PROPERTIES OF FLUIDS

Density

The density of a fluid, denoted by ρ , is its mass per unit volume. Density is highly variable in gases and increases nearly proportionally to the pressure level. Density in liquids is nearly constant; the density of water (about 1000 kg/m³) increases only 1 percent if the pressure is increased by a factor of 220. Thus most liquid flows are treated analytically as nearly incompressible.

$$\rho = \frac{m}{V} \quad (\text{kg}/\text{m}^3)$$

$$m = \text{masa, kg}$$

$$V = \text{volumen, m}^3$$

Specific volume

$$v = \frac{V}{m} = \frac{1}{\rho}$$

Density of Ideal Gases

- **Equation of State:** equation for the relationship between pressure, temperature, and density.
- The simplest and best-known equation of state is the ideal-gas equation.

$$P v = R T \quad \text{or} \quad P = \rho R T$$

- Ideal-gas equation holds for most gases.
- However, dense gases such as water vapor and refrigerant vapor should not be treated as ideal gases.

Specific weight

The specific weight of a fluid, denoted by γ , is its weight per unit volume. Just as a mass a weight $W = mg$, density and specific weight are simply related by gravity

$$\gamma = \rho g \quad (N/m^3)$$

$$\rho = \text{densidad, } kg / m^3$$

$$g = \text{aceleración de la gravedad, } m / s^2$$

$$\gamma_{air} = (1,205 \text{ kg} / m^3) (9,807 \text{ m} / s^2) = 11,8 \text{ N} / m^3 = 0,0752 \text{ lbf} / ft^3$$

$$\gamma_{water} = (998 \text{ kg} / m^3) (9,807 \text{ m} / s^2) = 9790 \text{ N} / m^3 = 62,4 \text{ lbf} / ft^3$$

Specific gravity

The specific gravity, denoted by SG, is the ratio of a fluid density to a standard reference fluid, water (for liquids), and air (for gases)

$$SG_{gas} = \frac{\rho_{gas}}{\rho_{air}} = \frac{\rho_{gas}}{1,205 \text{ kg/m}^3}$$

$$SG_{liquid} = \frac{\rho_{liquid}}{\rho_{water}} = \frac{\rho_{liquid}}{998 \text{ kg/m}^3}$$

For example, the specific gravity of mercury (Hg) is $SG_{Hg} = 13580/998 \approx 13,6$. These dimensionless ratios are easier to remember than the actual numerical values of density of a variety of fluids

Specific gravity

Specific gravities of some substances at 0°C

Substance	SG
Water	1.0
Blood	1.05
Seawater	1.025
Gasoline	0.7
Ethyl alcohol	0.79
Mercury	13.6
Wood	0.3–0.9
Gold	19.2
Bones	1.7–2.0
Ice	0.92
Air (at 1 atm)	0.0013

Vapor Pressure and Cavitation

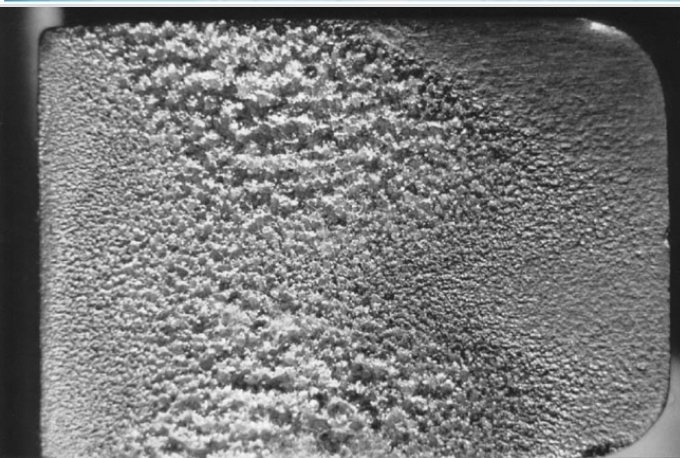
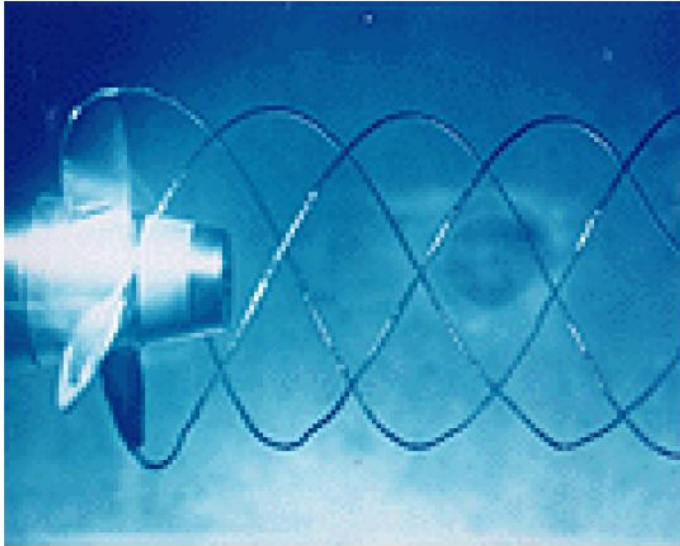

- **Vapor Pressure** P_v is defined as *the pressure exerted by its vapor in phase equilibrium with its liquid at a given temperature*
- If P drops below P_v , liquid is locally vaporized, creating cavities of vapor.
- Vapor cavities collapse when local P rises above P_v .
- Collapse of cavities is a violent process which can damage machinery.
- Cavitation is noisy, and can cause structural vibrations.

Energy and Specific Heats

- Total energy E is comprised of numerous forms: thermal, mechanical, kinetic, potential, electrical, magnetic, chemical, and nuclear.
- Units of energy are *joule (J)* or *British thermal unit (BTU)*.
- Microscopic energy
 - ✓ Internal energy u is for a non-flowing fluid and is due to molecular activity.
 - ✓ Enthalpy $h=u+Pv$ is for a flowing fluid and includes flow energy (Pv).
- Macroscopic energy
 - ✓ Kinetic energy $ke=V^2/2$
 - ✓ Potential energy $pe=gz$
- In the absence of electrical, magnetic, chemical, and nuclear energy, the total energy is $e_{flowing}=h+V^2/2+gz$.

Compressibility and expansion

- How does fluid volume change with P and T ?
- Fluids expand as $T \uparrow$ or $P \downarrow$
- Fluids contract as $T \downarrow$ or $P \uparrow$
- Need fluid properties that relate volume changes to changes in P and T .
 - ✓ Coefficient of compressibility

$$\kappa = -v \left(\frac{\partial P}{\partial v} \right)_T = \rho \left(\frac{\partial P}{\partial \rho} \right)_T$$

- ✓ Coefficient of volume expansion

$$\beta = \frac{1}{v} \left(\frac{\partial v}{\partial T} \right)_P = -\frac{1}{\rho} \left(\frac{\partial \rho}{\partial T} \right)_P$$

- Combined effects of P and T can be written as

$$dv = \left(\frac{\partial v}{\partial T} \right)_P dT + \left(\frac{\partial v}{\partial P} \right)_T dP$$

Coefficient of Compressibility

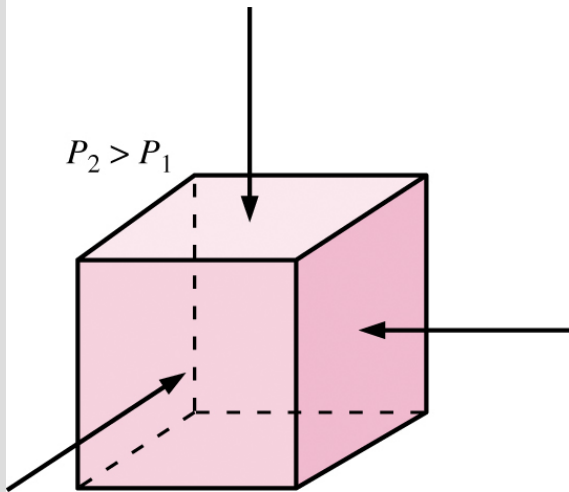
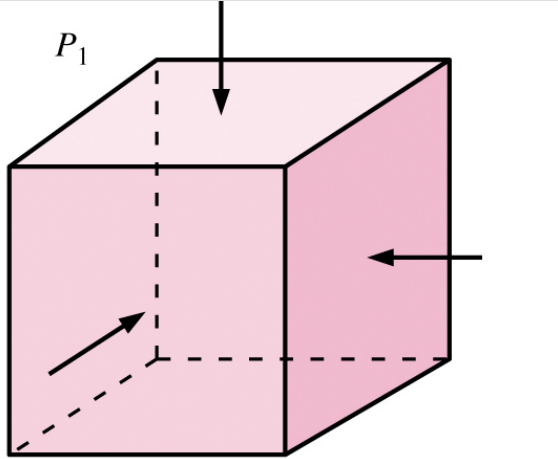

$$k = -v \left(\frac{\partial P}{\partial v} \right)_T = \rho \left(\frac{\partial P}{\partial \rho} \right)_T \quad (\text{Pa, psi})$$

in terms of finite changes as

$$k \cong \frac{\Delta P}{\Delta v/v} \cong \frac{\Delta P}{\Delta \rho/\rho} \quad (\text{Pa, psi})$$

Coefficient of Compressibility

The density of seawater at a free surface where the pressure is 98 kPa is approximately 1030 kg/m^3 . Taking the bulk modulus of elasticity of seawater to be $2.34 \times 10^9 \text{ N/m}^2$ and expressing variation of pressure with depth z as $dP = \rho g dz$ determine the density and pressure at a depth of 2500 m. Disregard the effect of temperature

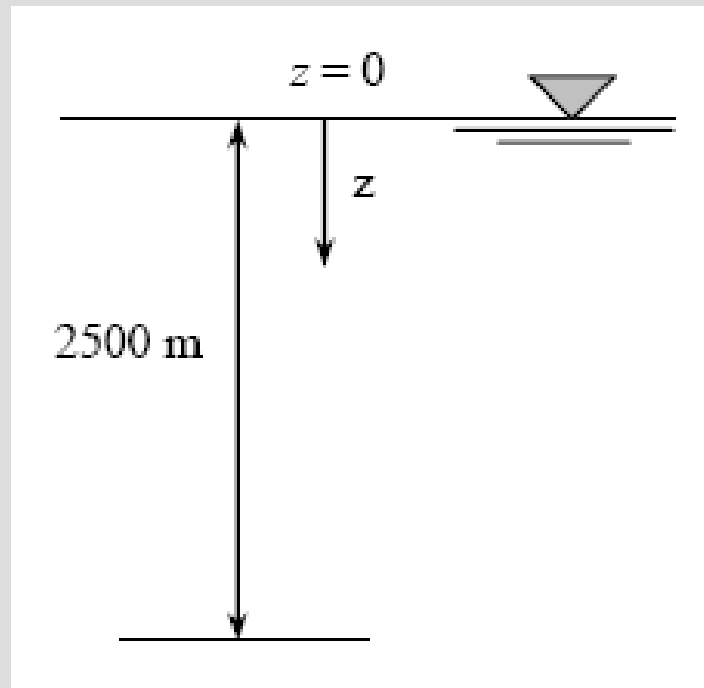

Coefficient of Volume Expansion

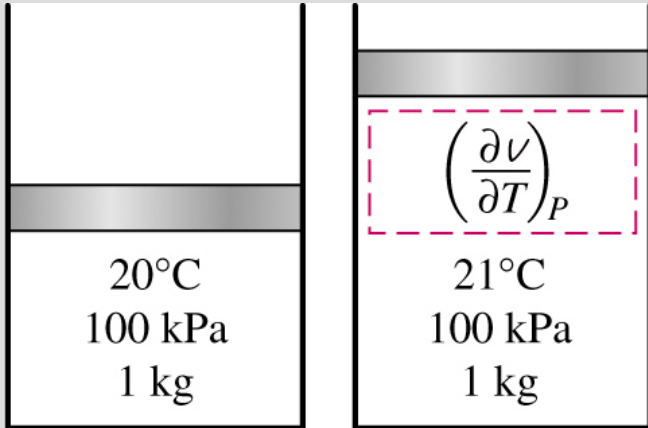

(a) A substance with a large β

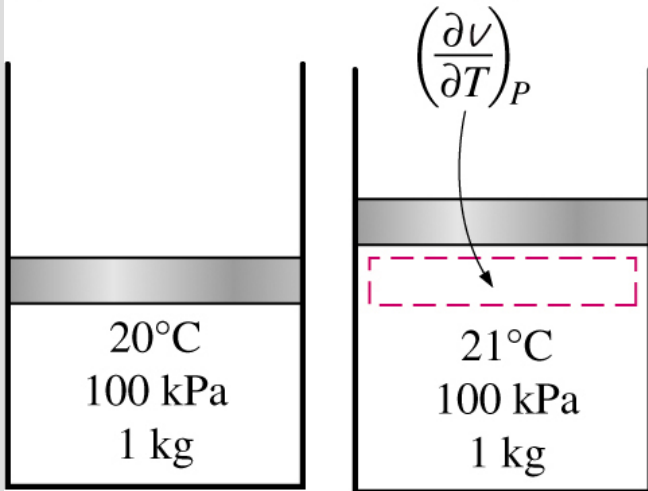

(b) A substance with a small β

$$\beta = \frac{1}{v} \left(\frac{\partial v}{\partial T} \right)_P = -\frac{1}{\rho} \left(\frac{\partial \rho}{\partial T} \right)_P \quad \left(\frac{1}{\text{K}} \right)$$

in terms of finite changes as

$$\beta \cong \frac{\Delta v/v}{\Delta T} \cong -\frac{\Delta \rho/\rho}{\Delta T} \quad \left(\frac{1}{\text{K}} \right)$$

$$\beta_{\text{ideal gas}} = \frac{1}{T} \quad \left(\frac{1}{\text{K}} \right)$$

Coefficient of Volume Expansion

The combined effects of pressure and temperature changes on the volume change of a fluid can be determined by taking the specific volume to be a function of T and P

$$dv = \left(\frac{\partial v}{\partial T} \right)_P dT + \left(\frac{\partial v}{\partial P} \right)_T dP = (\beta dT - \alpha dP)v$$

Then the change in volume (or density) due to changes in pressure and temperature can be expressed approximately as

$$\frac{\Delta v}{v} = -\frac{\Delta \rho}{\rho} \cong \beta \Delta T - \alpha \Delta P$$

Coefficient of Volume Expansion

A water tank is completely filled with liquid water at 20°C . The tank material is such that it can withstand tension caused by a volume expansion of 2 percent. Determine the maximum temperature rise allowed without jeopardizing safety.

Surface Tension

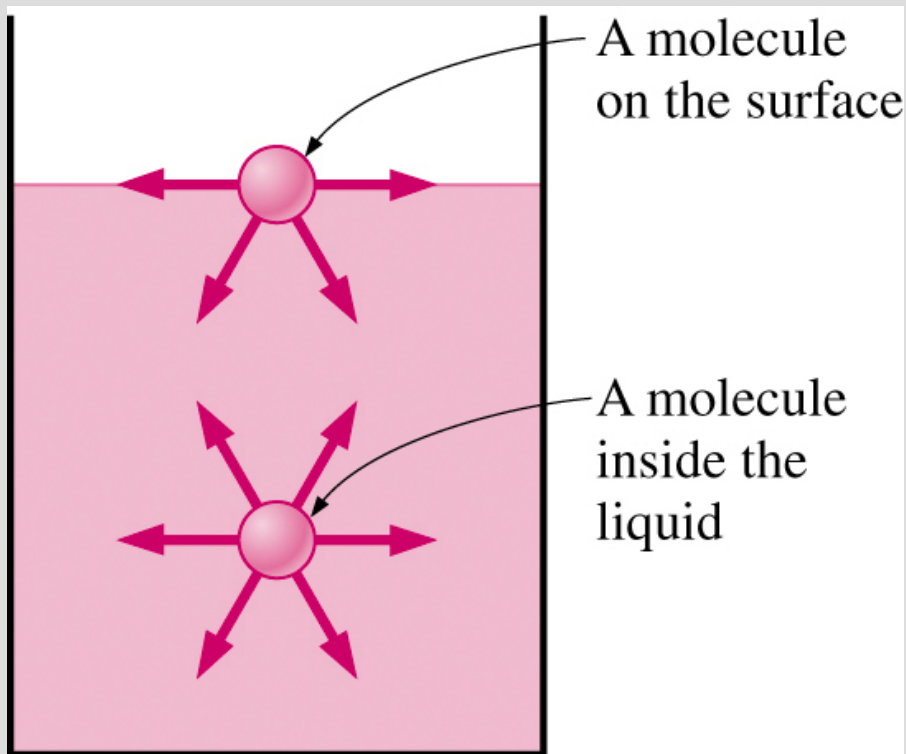

- Liquid droplets behave like small spherical balloons filled with liquid, and the surface of the liquid acts like a stretched elastic membrane under tension.
- The pulling force that causes this is
 - ✓ due to the attractive forces between molecules
 - ✓ called **surface tension** σ_s .
- Attractive force on surface molecule is not symmetric.
- Repulsive forces from interior molecules causes the liquid to minimize its surface area and attain a spherical shape.

Capillary Effect

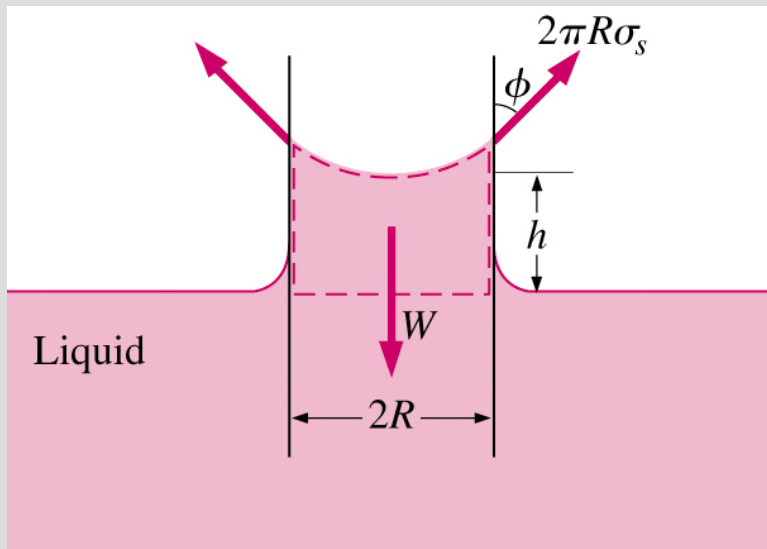
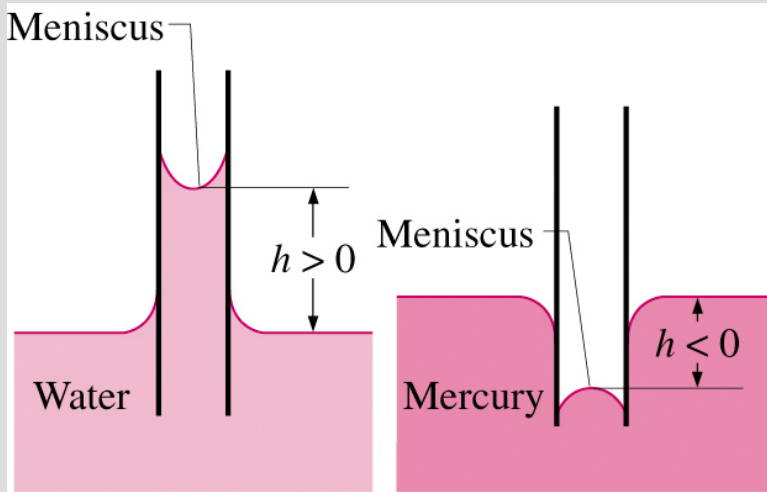

- **Capillary effect** is the rise or fall of a liquid in a small-diameter tube.
- The curved free surface in the tube is called the **meniscus**.
- Water meniscus curves up because water is a *wetting fluid*.
- Mercury meniscus curves down because mercury is a *nonwetting fluid*.
- Force balance can describe magnitude of capillary rise.

Viscosity

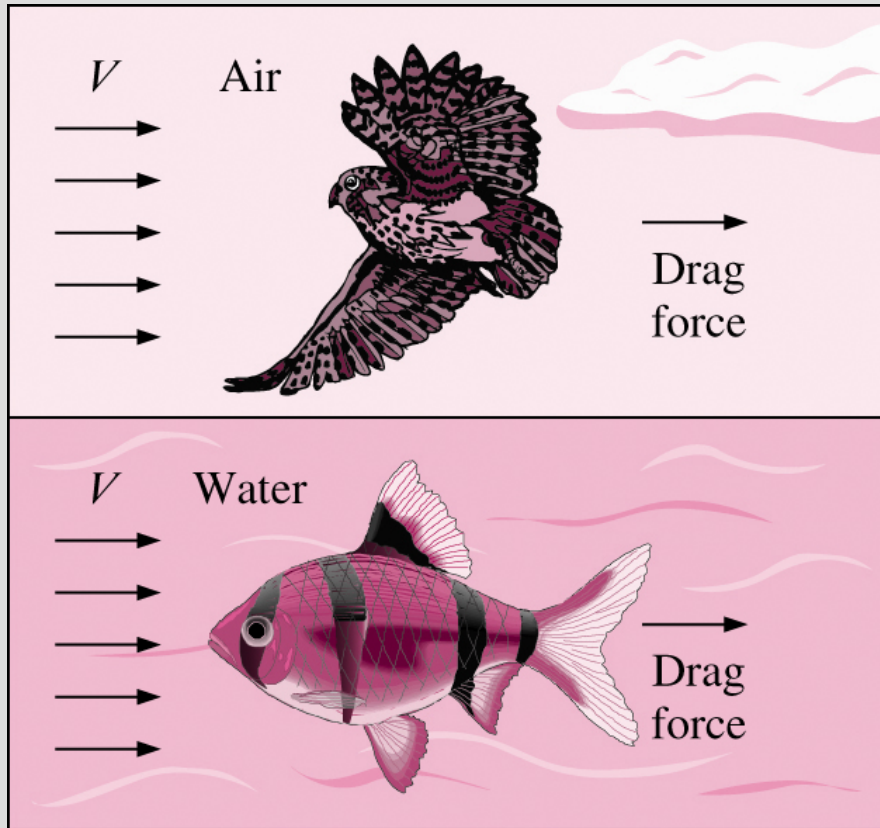

- **Viscosity** is a property that represents the internal resistance of a fluid to motion.
- The force a flowing fluid exerts on a body in the flow direction is called the **drag force**, and the magnitude of this force depends, in part, on viscosity.

Viscosity

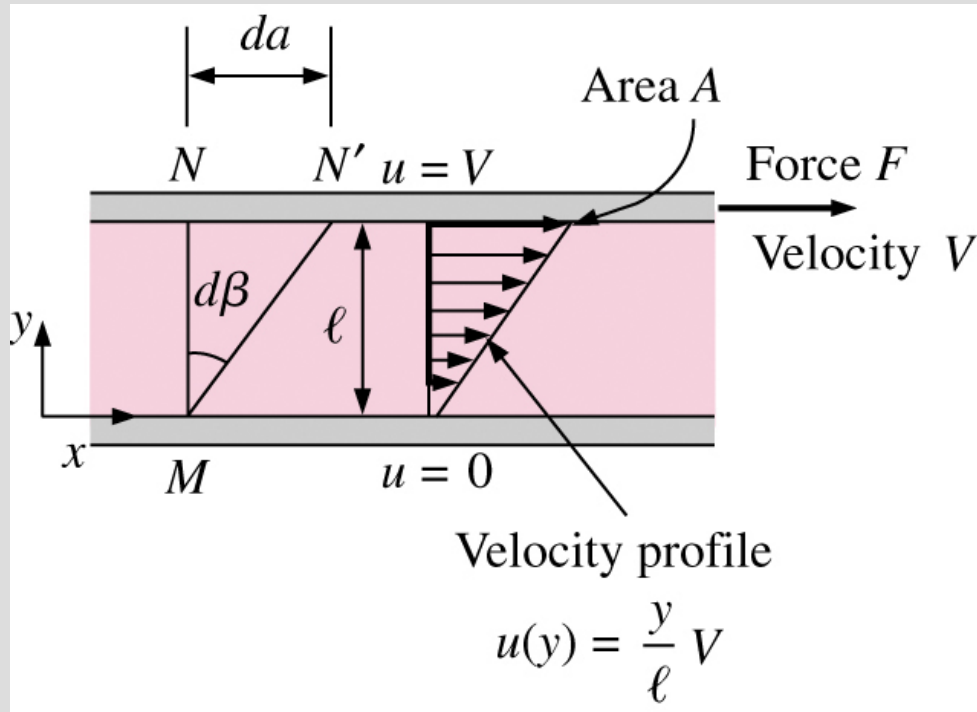

The behavior of a fluid in laminar flow between two parallel plates when the upper plate moves with a constant velocity.

Shear stress

$$\tau = \mu \frac{du}{dy} \quad (\text{N/m}^2)$$

Shear force

$$F = \tau A = \mu A \frac{du}{dy} \quad (\text{N})$$

μ dynamic viscosity

$\text{kg/m} \cdot \text{s}$ or $\text{N} \cdot \text{s/m}^2$ or $\text{Pa} \cdot \text{s}$

1 poise = 0.1 Pa · s

$$\tau \propto \frac{d(d\beta)}{dt} \quad \text{or} \quad \tau \propto \frac{du}{dy}$$

Fluids for which the rate of deformation is proportional to the shear stress are called **Newtonian fluids**.

Viscosity

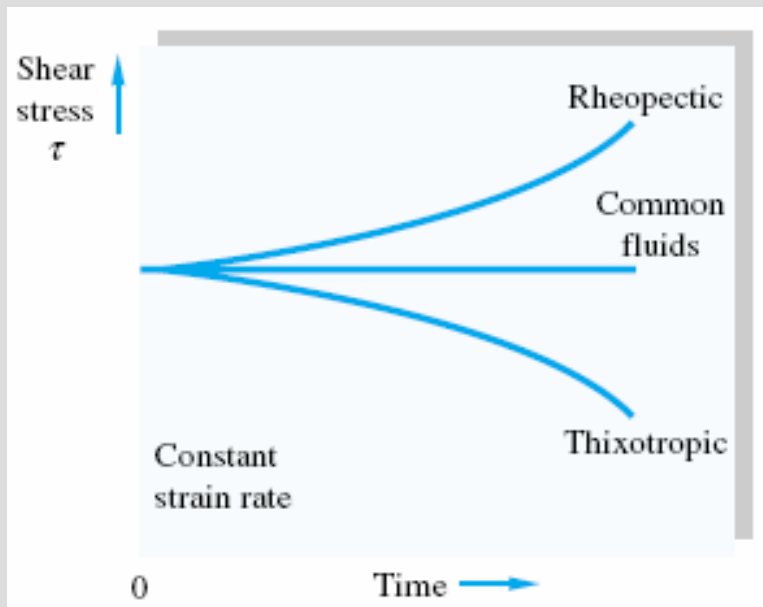
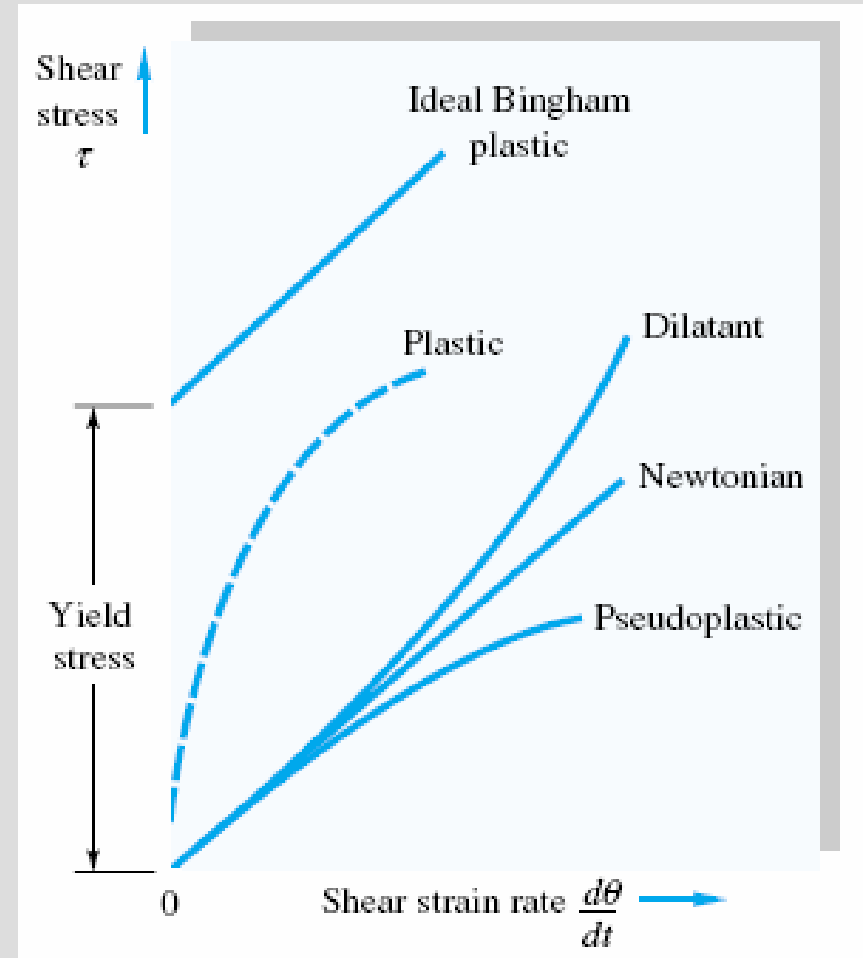
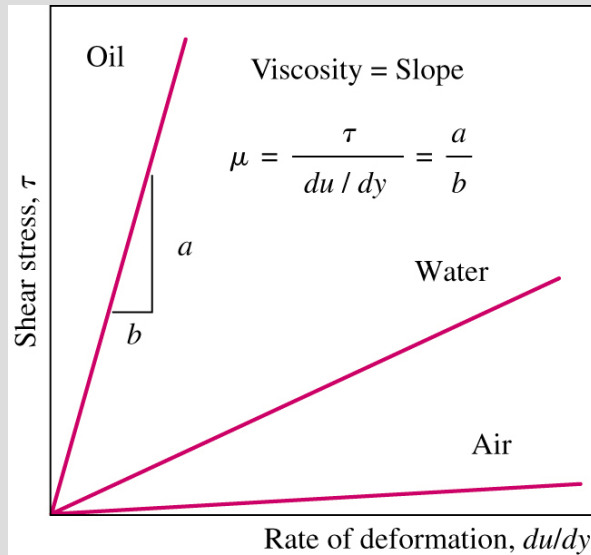

Viscosity

Air at 20°C and 1 atm:

$$\mu = 1.83 \times 10^{-5} \text{ kg/m} \cdot \text{s}$$

$$\nu = 1.52 \times 10^{-5} \text{ m}^2/\text{s}$$

Air at 20°C and 4 atm:

$$\mu = 1.83 \times 10^{-5} \text{ kg/m} \cdot \text{s}$$

$$\nu = 0.380 \times 10^{-5} \text{ m}^2/\text{s}$$

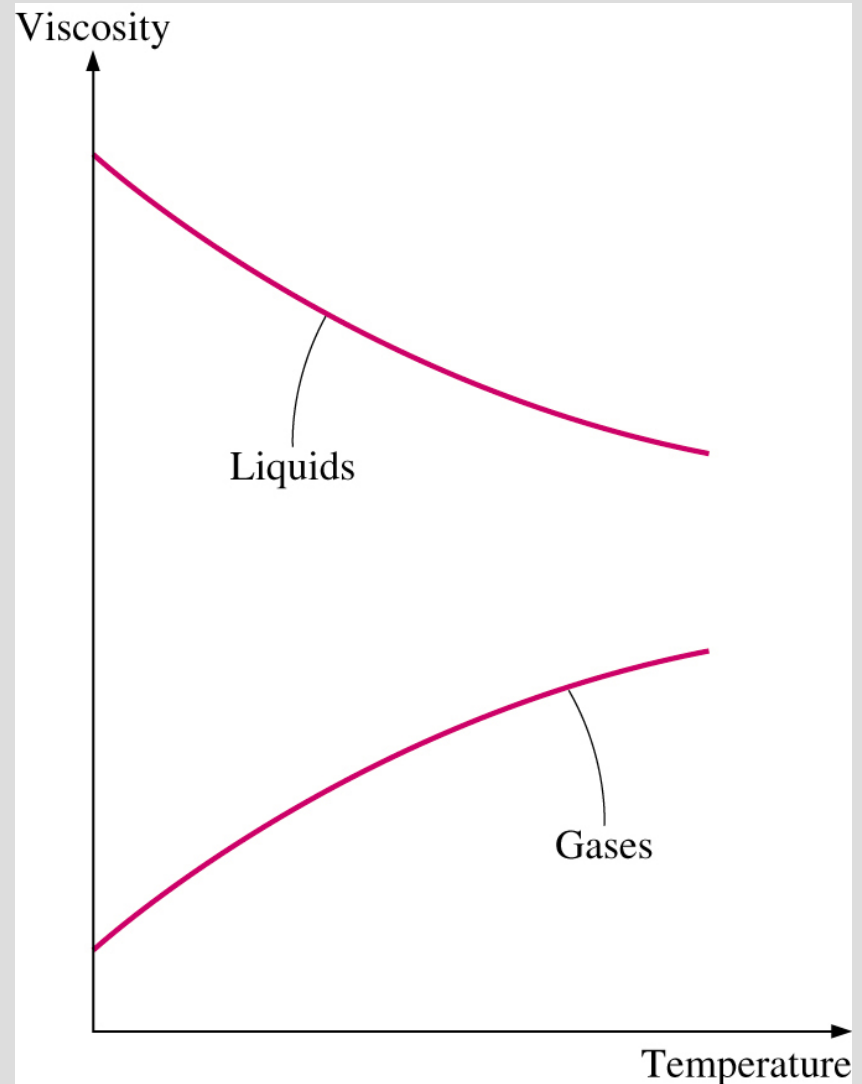

Viscosity

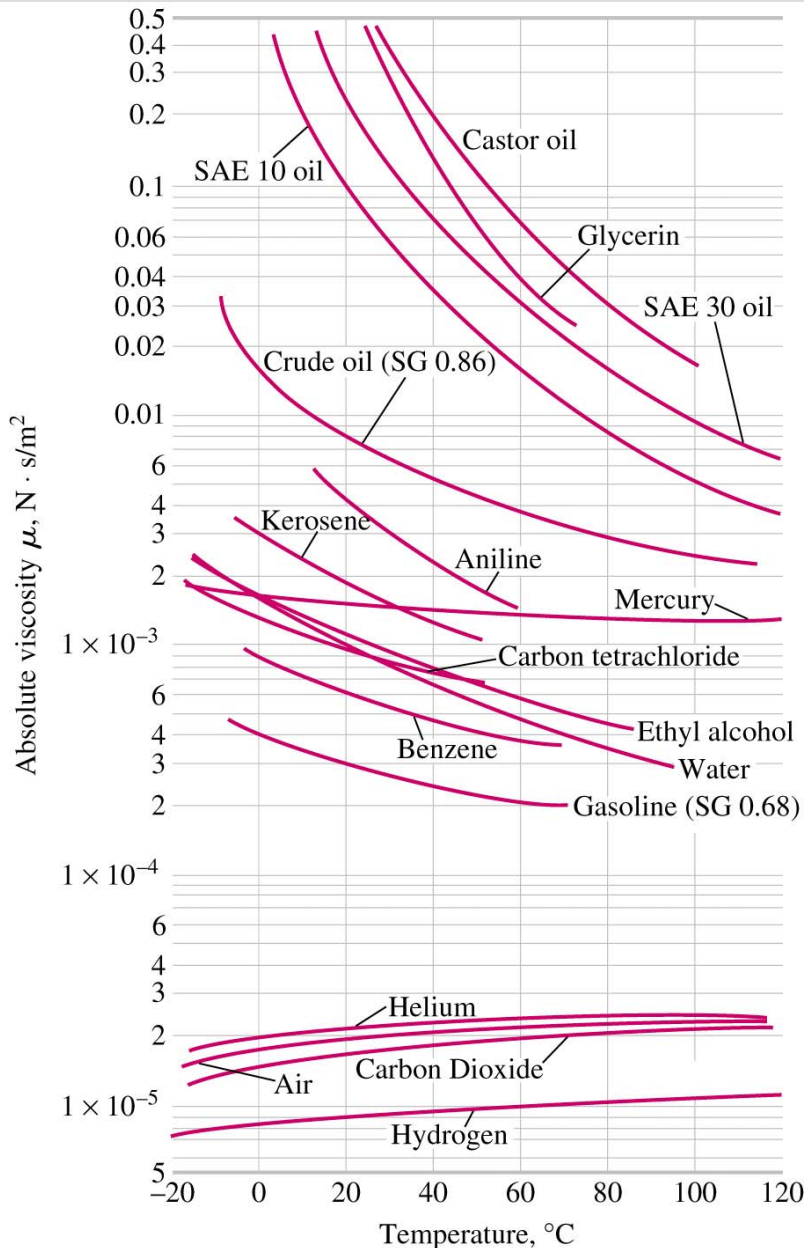

Dynamic viscosities of some fluids at 1 atm and 20°C (unless otherwise stated)

Fluid	Dynamic Viscosity μ , $\text{kg}/\text{m}\cdot\text{s}$
Glycerin:	
-20°C	134.0
0°C	10.5
20°C	1.52
40°C	0.31
Engine oil:	
SAE 10W	0.10
SAE 10W30	0.17
SAE 30	0.29
SAE 50	0.86
Mercury	0.0015
Ethyl alcohol	0.0012
Water:	
0°C	0.0018
20°C	0.0010
100°C (liquid)	0.00028
100°C (vapor)	0.000012
Blood, 37°C	0.00040
Gasoline	0.00029
Ammonia	0.00015
Air	0.000018
Hydrogen, 0°C	0.0000088

Viscosity

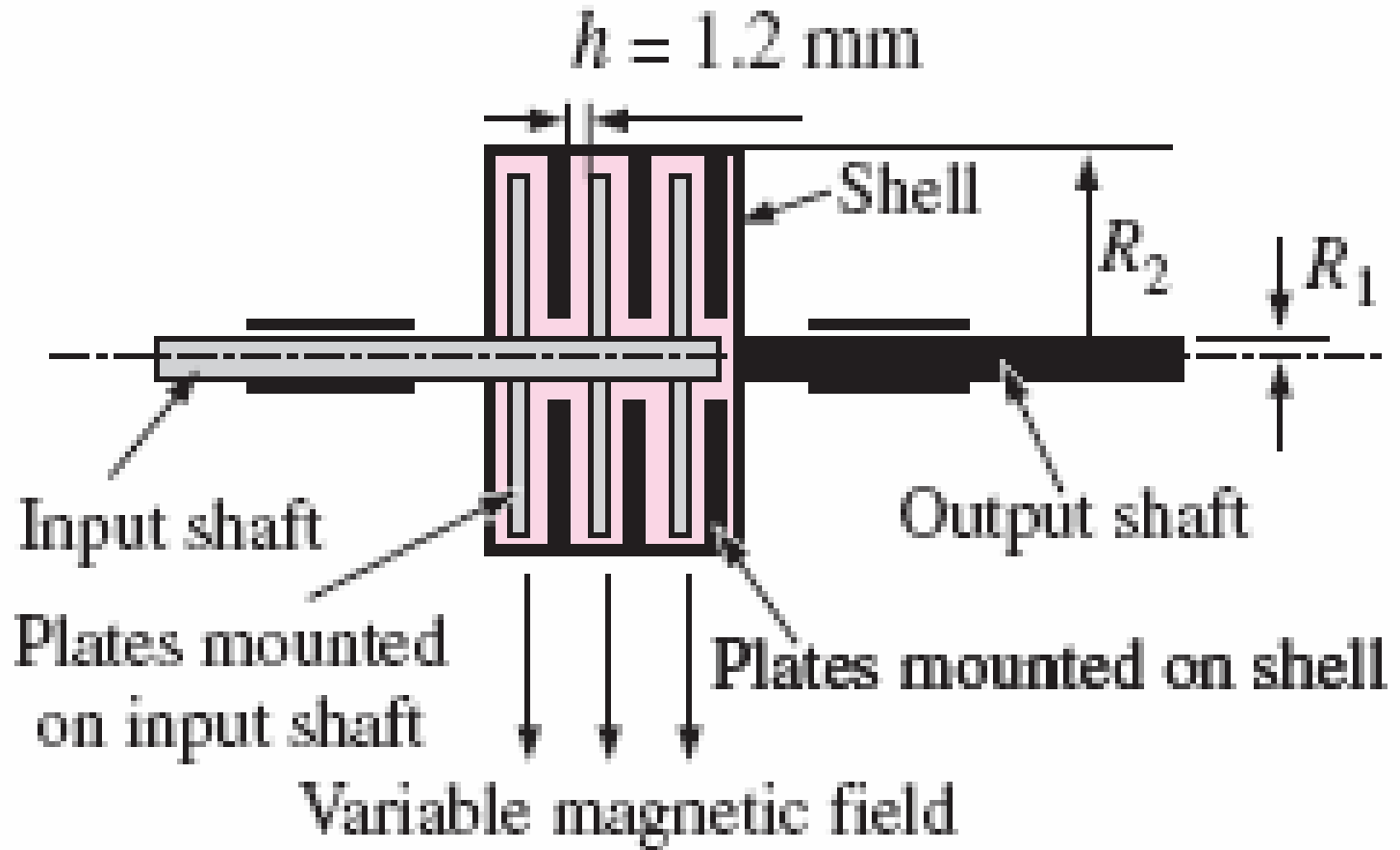

Viscosity

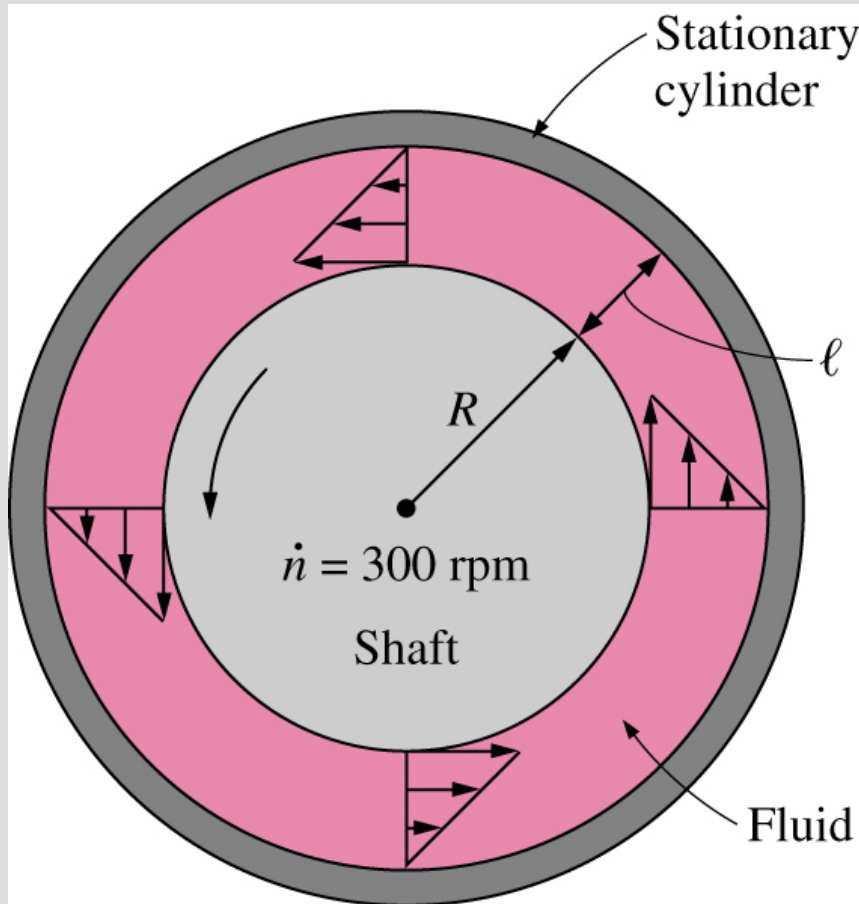

L length of the cylinder

\dot{n} number of revolutions per unit time

This equation can be used to calculate the viscosity of a fluid by measuring torque at a specified angular velocity.

Therefore, two concentric cylinders can be used as a **viscometer**, a device that measures viscosity.

$$T = FR = \mu \frac{2\pi R^3 \omega L}{\ell} = \mu \frac{4\pi^2 R^3 \dot{n} L}{\ell}$$

TEMPERATURE AND THE ZEROth LAW OF THERMODYNAMICS

- **The zeroth law of thermodynamics:** If two bodies are in thermal equilibrium with a third body, they are also in thermal equilibrium with each other.
- By replacing the third body with a thermometer, the zeroth law can be restated as *two bodies are in thermal equilibrium if both have the same temperature reading even if they are not in contact.*

Two bodies reaching thermal equilibrium after being brought into contact in an isolated enclosure.

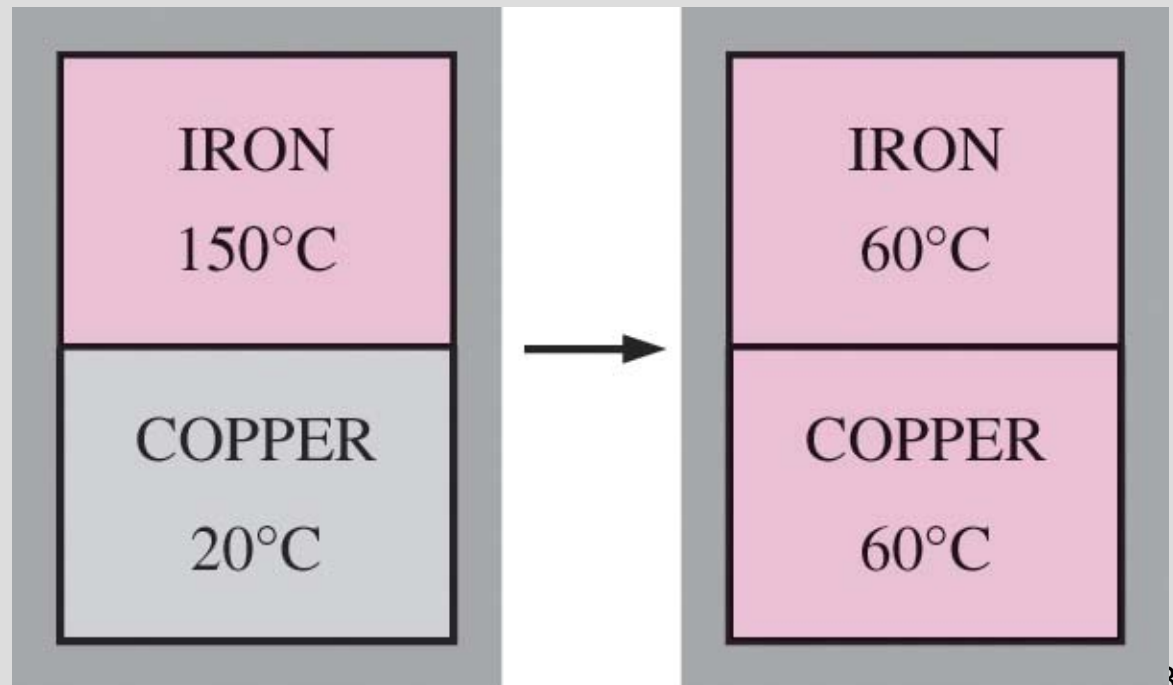

Temperature Scales

- All temperature scales are based on some easily reproducible states such as the freezing and boiling points of water: the *ice point* and the *steam point*.
- **Ice point:** A mixture of ice and water that is in equilibrium with air saturated with vapor at 1 atm pressure (0°C or 32°F).
- **Steam point:** A mixture of liquid water and water vapor (with no air) in equilibrium at 1 atm pressure (100°C or 212°F).
- **Celsius scale:** in SI unit system
- **Fahrenheit scale:** in English unit system
- **Thermodynamic temperature scale:** A temperature scale that is independent of the properties of any substance.
- **Kelvin scale** (SI) **Rankine scale** (E)
- A temperature scale nearly identical to the Kelvin scale is the **ideal-gas temperature scale**. The temperatures on this scale are measured using a **constant-volume gas thermometer**.

P versus T plots of the experimental data obtained from a constant-volume gas thermometer using four different gases at different (but low) pressures.

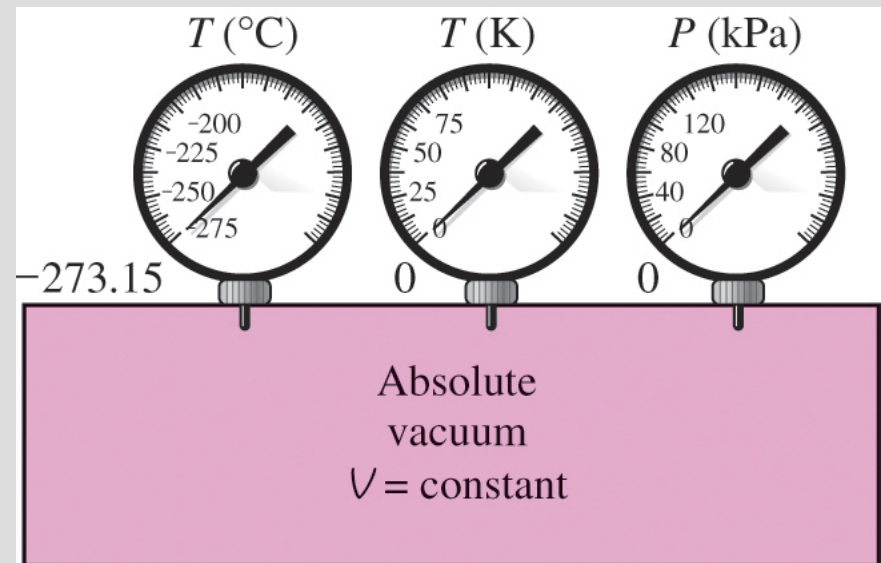
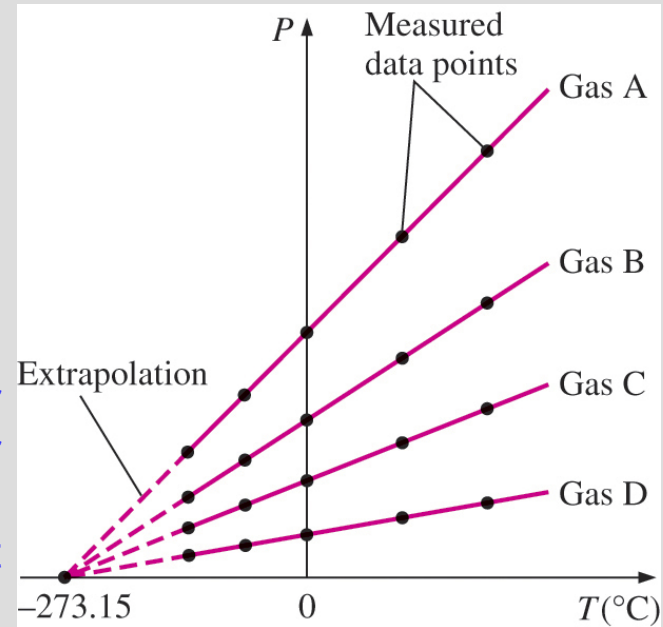

A constant-volume gas thermometer would read 273.15°C at absolute zero pressure. 59

$$T(\text{K}) = T(^{\circ}\text{C}) + 273.15$$

$$T(\text{R}) = T(^{\circ}\text{F}) + 459.67$$

$$T(\text{R}) = 1.8T(\text{K})$$

$$T(^{\circ}\text{F}) = 1.8T(^{\circ}\text{C}) + 32$$

$$\Delta T(\text{K}) = \Delta T(^{\circ}\text{C})$$

$$\Delta T(\text{R}) = \Delta T(^{\circ}\text{F})$$

Comparison of temperature scales.

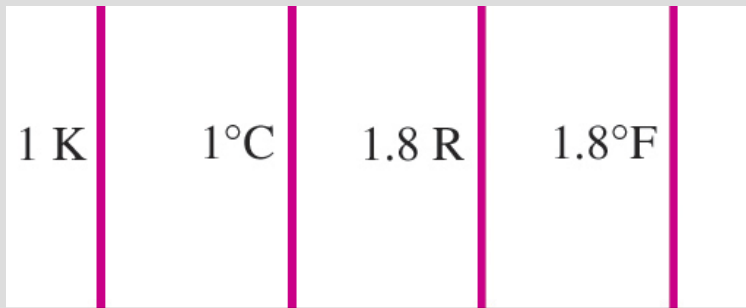

Comparison of magnitudes of various temperature units.

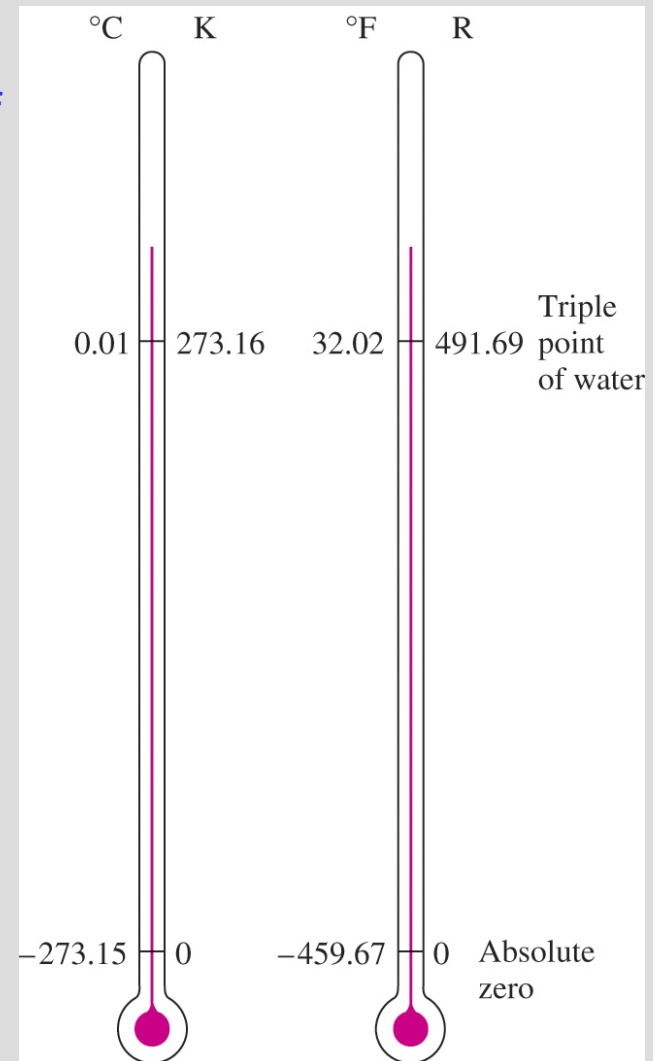

- The reference temperature in the original Kelvin scale was the *ice point*, 273.15 K, which is the temperature at which water freezes (or ice melts).
- The reference point was changed to a much more precisely reproducible point, the *triple point* of water (the state at which all three phases of water coexist in equilibrium), which is assigned the value 273.16 K.