

CLASS
HIDROSTATIC
Pressure, Manometers

Copyright © The McGraw-Hill Companies, Inc. Permission required for reproduction or display.

PRESSURE

Pressure: A normal force exerted by a fluid per unit area

$$1 \text{ Pa} = 1 \text{ N/m}^2$$

$$1 \text{ bar} = 10^5 \text{ Pa} = 0.1 \text{ MPa} = 100 \text{ kPa}$$

$$1 \text{ atm} = 101,325 \text{ Pa} = 101.325 \text{ kPa} = 1.01325 \text{ bars}$$

$$1 \text{ kgf/cm}^2 = 9.807 \text{ N/cm}^2 = 9.807 \times 10^4 \text{ N/m}^2 = 9.807 \times 10^4 \text{ Pa}$$

$$= 0.9807 \text{ bar}$$

$$= 0.9679 \text{ atm}$$

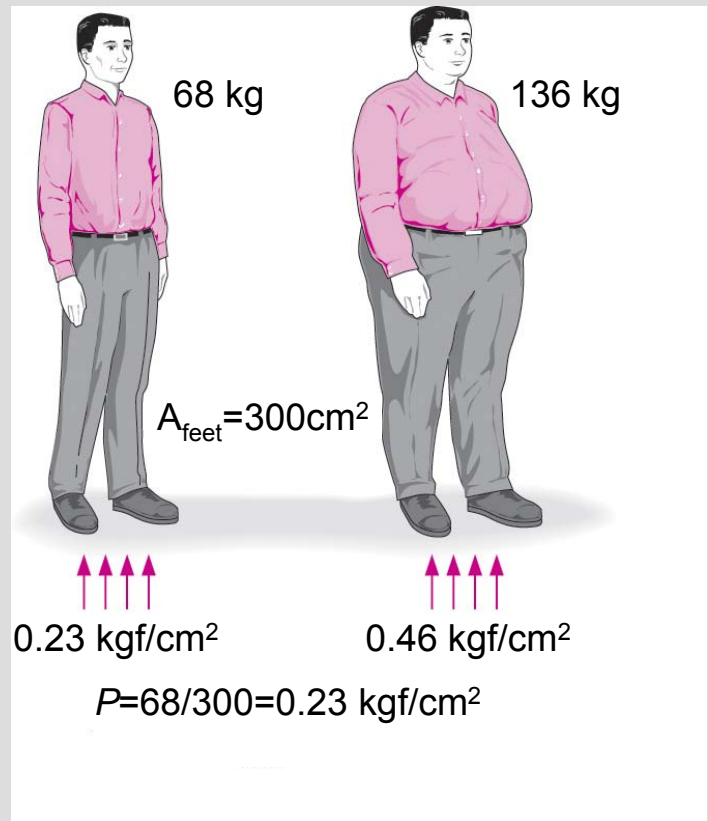

The normal stress (or “pressure”) on the feet of a chubby person is much greater than on the feet of a slim person.



Some basic pressure gages.

- **Absolute pressure:** The actual pressure at a given position. It is measured relative to absolute vacuum (i.e., absolute zero pressure).
- **Gage pressure:** The difference between the absolute pressure and the local atmospheric pressure. Most pressure-measuring devices are calibrated to read zero in the atmosphere, and so they indicate gage pressure.
- **Vacuum pressures:** Pressures below atmospheric pressure.

Throughout this text, the pressure P will denote **absolute pressure** unless specified otherwise.

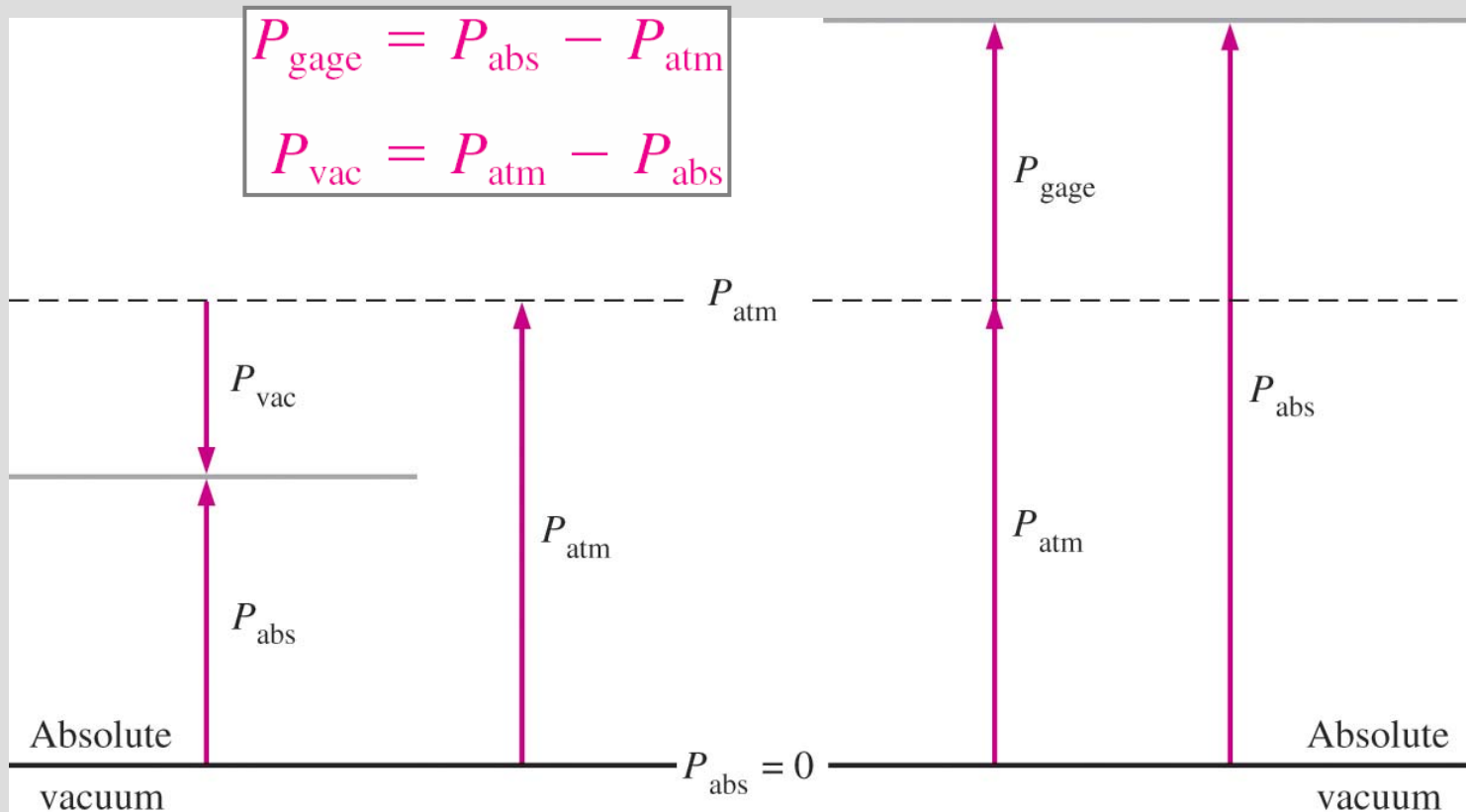

Other Pressure Measurement Devices

- **Bourdon tube:** Consists of a hollow metal tube bent like a hook whose end is closed and connected to a dial indicator needle.
- **Pressure transducers:** Use various techniques to convert the pressure effect to an electrical effect such as a change in voltage, resistance, or capacitance.
- Pressure transducers are smaller and faster, and they can be more sensitive, reliable, and precise than their mechanical counterparts.
- **Strain-gage pressure transducers:** Work by having a diaphragm deflect between two chambers open to the pressure inputs.
- **Piezoelectric transducers:** Also called **solid-state pressure transducers**, work on the principle that an electric potential is generated in a crystalline substance when it is subjected to mechanical pressure.

Various types of Bourdon tubes used to measure pressure.

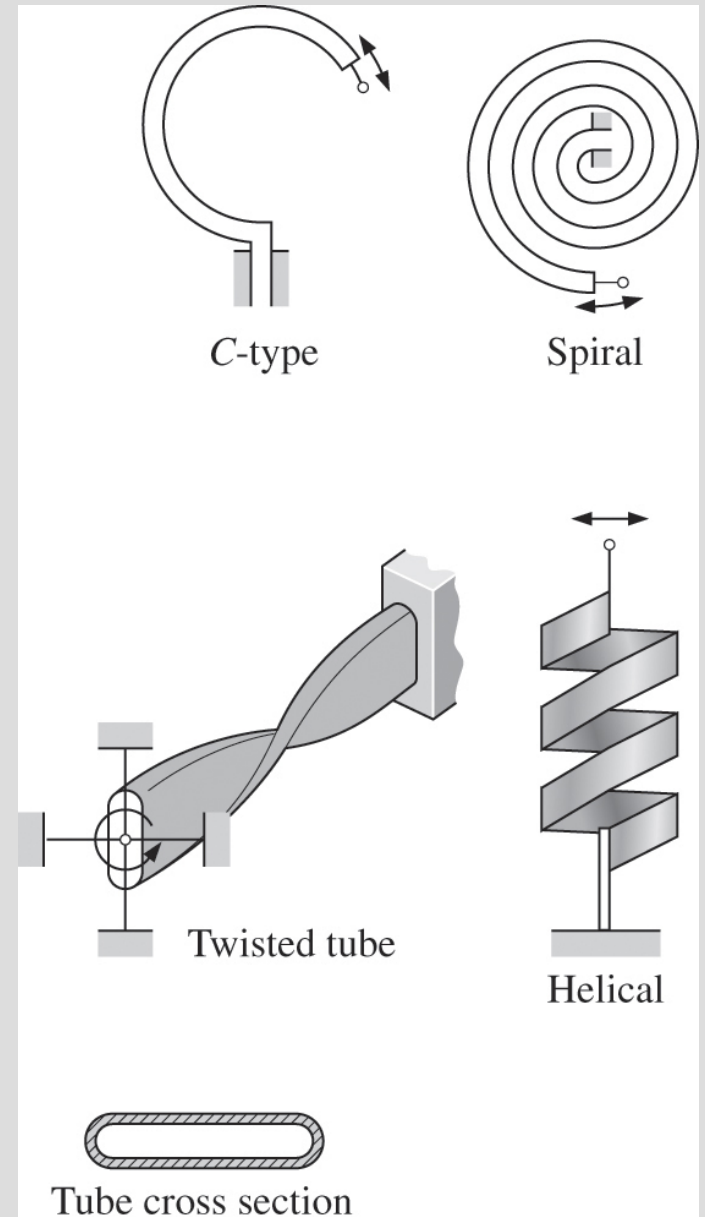

THE BAROMETER AND ATMOSPHERIC PRESSURE

- Atmospheric pressure is measured by a device called a **barometer**; thus, the atmospheric pressure is often referred to as the **barometric pressure**.
- A frequently used pressure unit is the **standard atmosphere**, which is defined as the pressure produced by a column of mercury 760 mm in height at 0°C ($\rho_{\text{Hg}} = 13,595 \text{ kg/m}^3$) under standard gravitational acceleration ($g = 9.807 \text{ m/s}^2$).

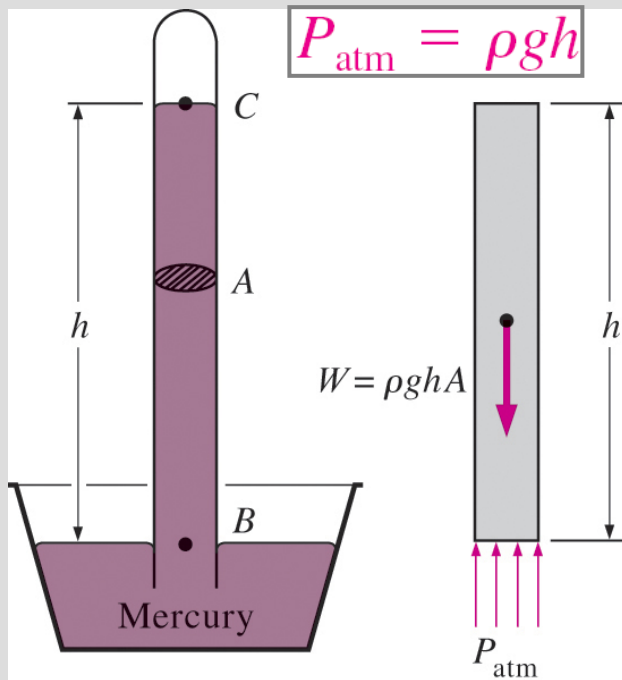

The basic barometer.

The length or the cross-sectional area of the tube has no effect on the height of the fluid column of a barometer, provided that the tube diameter is large enough to avoid surface tension (capillary) effects.

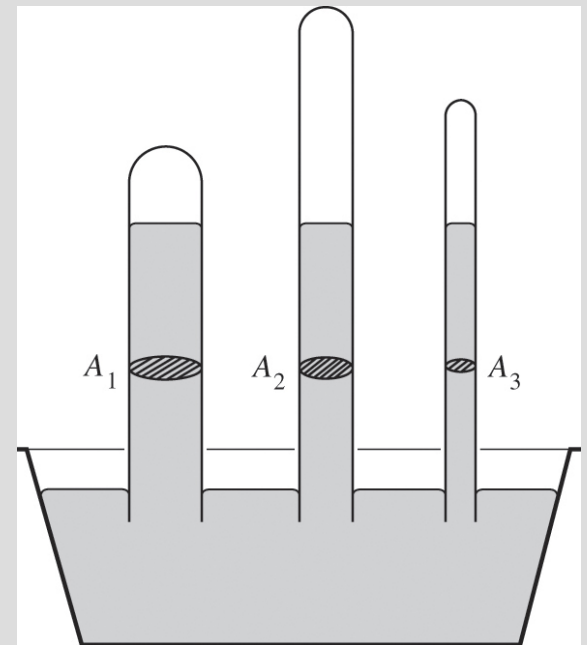

Scuba Diving and Hydrostatic Pressure



Scuba Diving and Hydrostatic Pressure

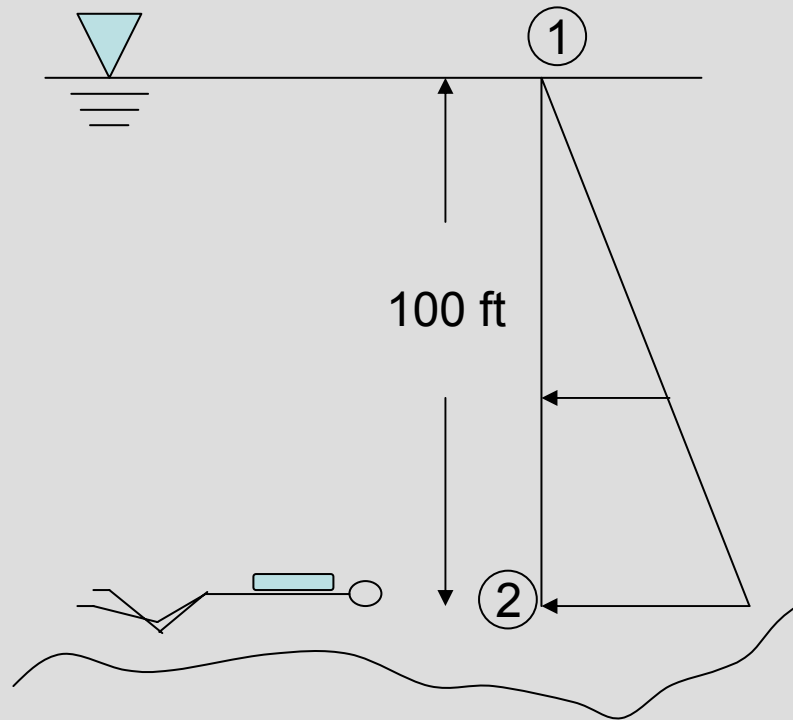

If you hold your breath on ascent, your lung volume would increase by a factor of 4, which would result in embolism and/or death.

- Pressure on diver at 100 ft?

$$P_{gage,2} = \rho g z = \left(998 \frac{kg}{m^3}\right) \left(9.81 \frac{m}{s^2}\right) (100 ft) \left(\frac{1m}{3.28 ft}\right)$$
$$= 298.5 kPa \left(\frac{1 atm}{101.325 kPa}\right) = 2.95 atm$$

$$P_{abs,2} = P_{gage,2} + P_{atm} = 2.95 atm + 1 atm = 3.95 atm$$

- Danger of emergency ascent? Boyle's law

$$P_1 V_1 = P_2 V_2$$

$$\frac{V_1}{V_2} = \frac{P_2}{P_1} = \frac{3.95 atm}{1 atm} \approx 4$$

Variation of Pressure with Depth

$$\Delta P = P_2 - P_1 = \rho g \Delta z = \gamma_s \Delta z$$

$$P = P_{\text{atm}} + \rho g h \quad \text{or} \quad P_{\text{gage}} = \rho g h$$

When the variation of density with elevation is known

$$\Delta P = P_2 - P_1 = - \int_1^2 \rho g dz$$

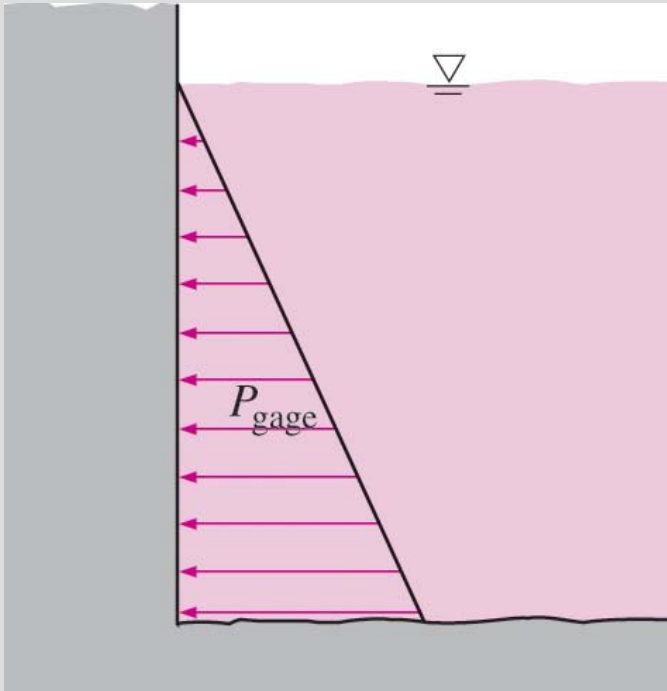

The pressure of a fluid at rest increases with depth (as a result of added weight).

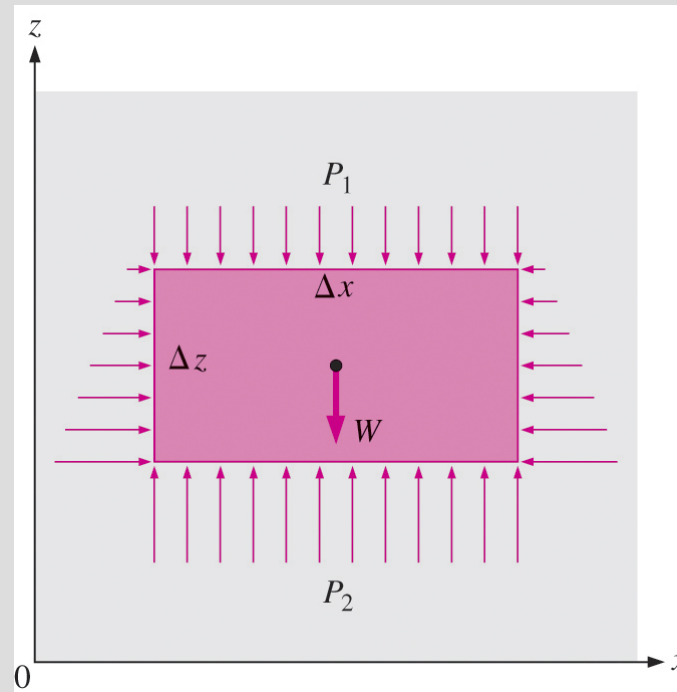

Free-body diagram of a rectangular fluid element in equilibrium.

In a room filled with a gas, the variation of pressure with height is negligible.

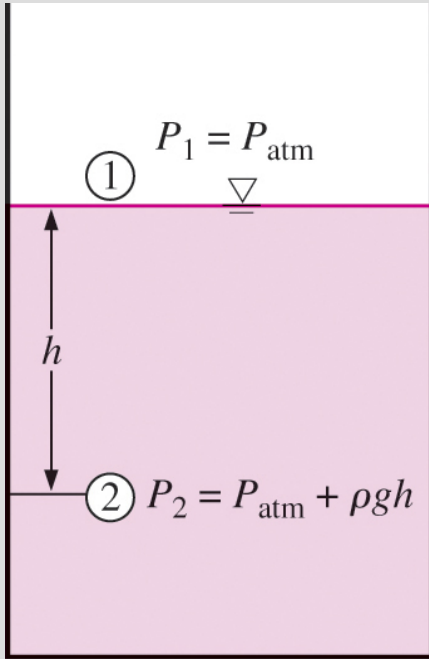
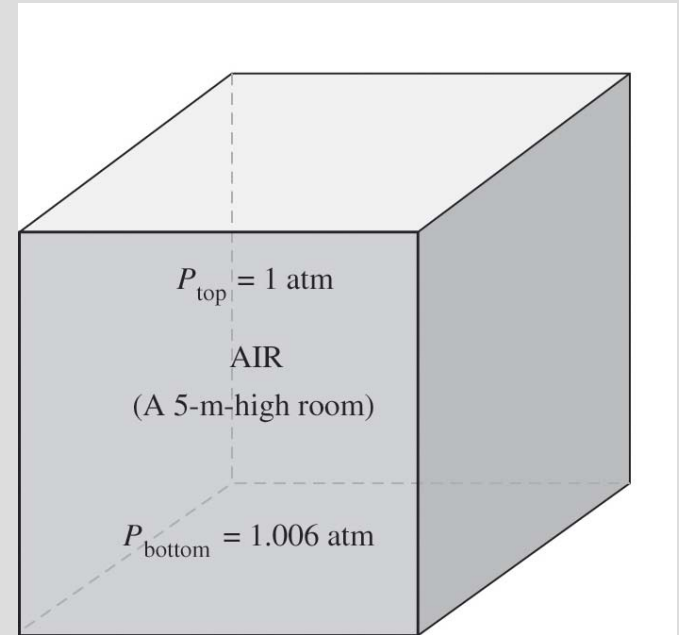

Pressure in a liquid at rest increases linearly with distance from the free surface.

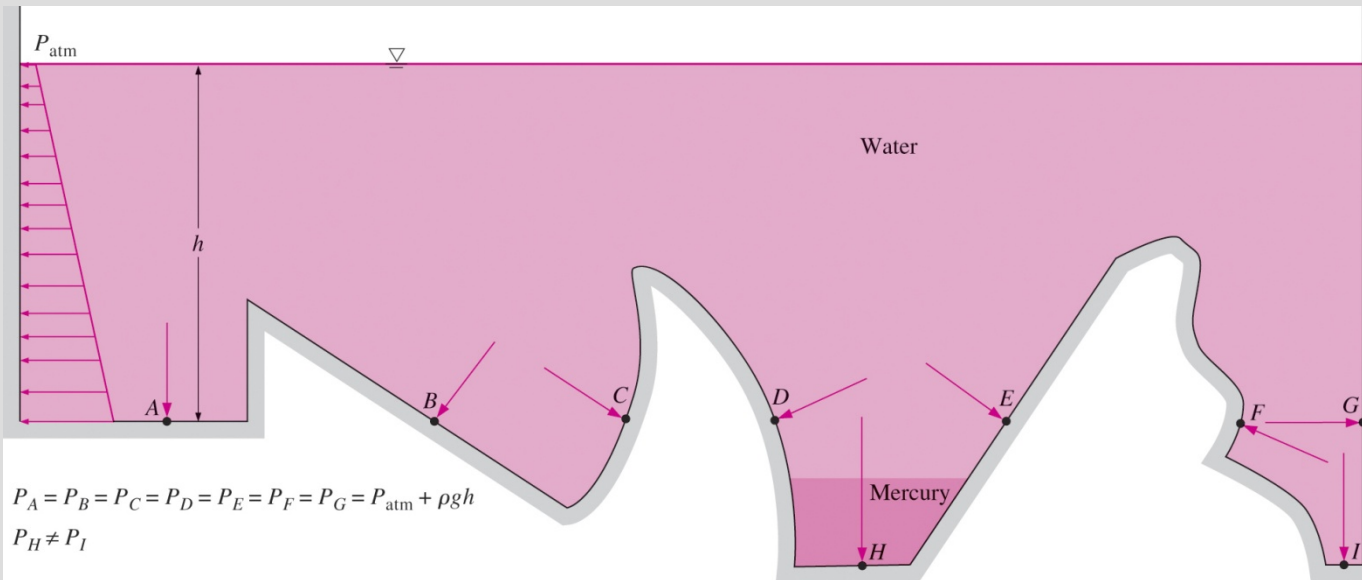

The pressure is the same at all points on a horizontal plane in a given fluid regardless of geometry, provided that the points are interconnected by the same fluid.

Pascal's law: The pressure applied to a confined fluid increases the pressure throughout by the same amount.

$$P_1 = P_2 \quad \rightarrow \quad \frac{F_1}{A_1} = \frac{F_2}{A_2} \quad \rightarrow \quad \frac{F_2}{F_1} = \frac{A_2}{A_1}$$

The area ratio A_2/A_1 is called the *ideal mechanical advantage* of the hydraulic lift.

Lifting of a large weight by a small force by the application of Pascal's law.

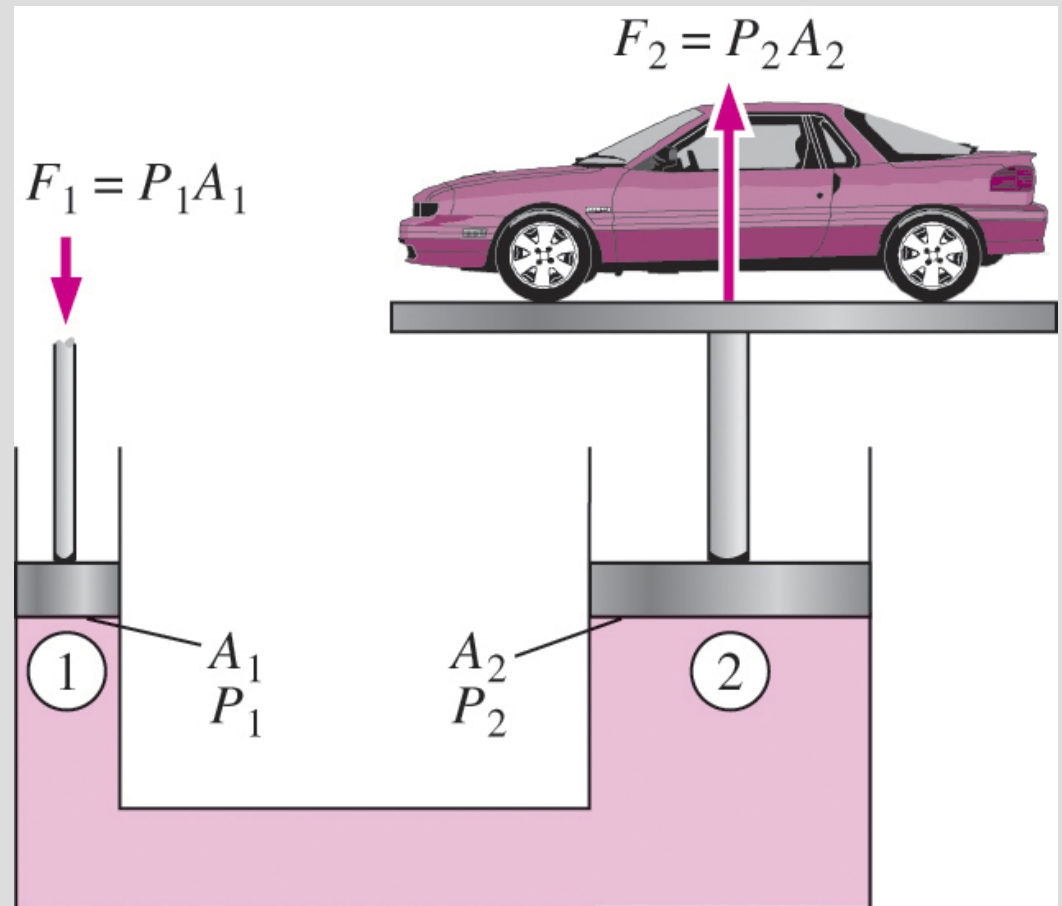

The Manometer

It is commonly used to measure small and moderate pressure differences. A manometer contains one or more fluids such as mercury, water, alcohol, or oil.

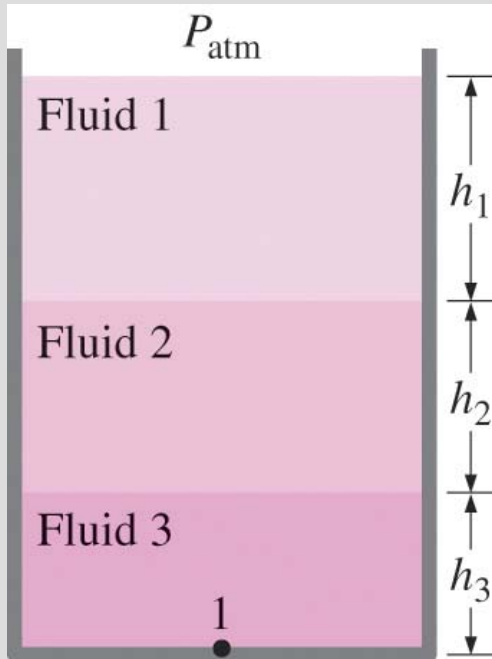

$$P_{\text{atm}} + \rho_1 g h_1 + \rho_2 g h_2 + \rho_3 g h_3 = P_1$$

In stacked-up fluid layers, the pressure change across a fluid layer of density ρ and height h is $\rho g h$.

Measuring the pressure drop across a flow section or a flow device by a differential manometer.

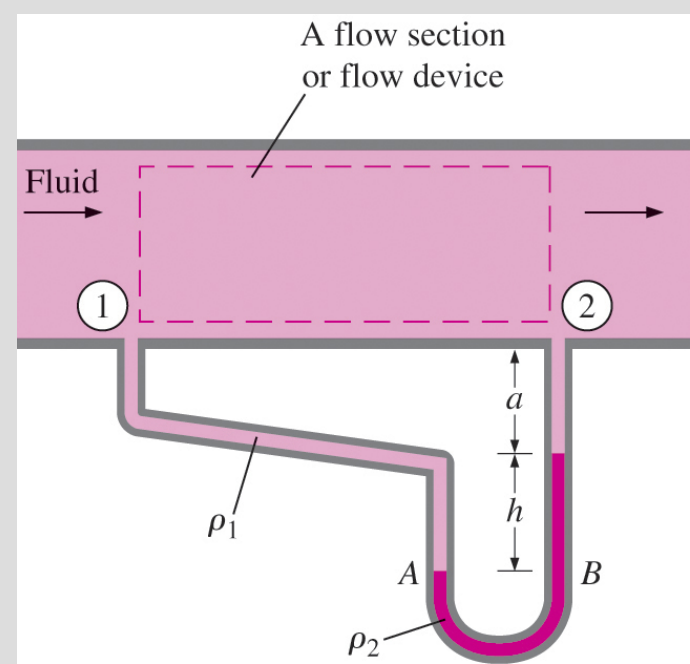

$$P_1 + \rho_1 g (a + h) - \rho_2 g h - \rho_1 g a = P_2$$

$$P_1 - P_2 = (\rho_2 - \rho_1) g h$$

The basic manometer.

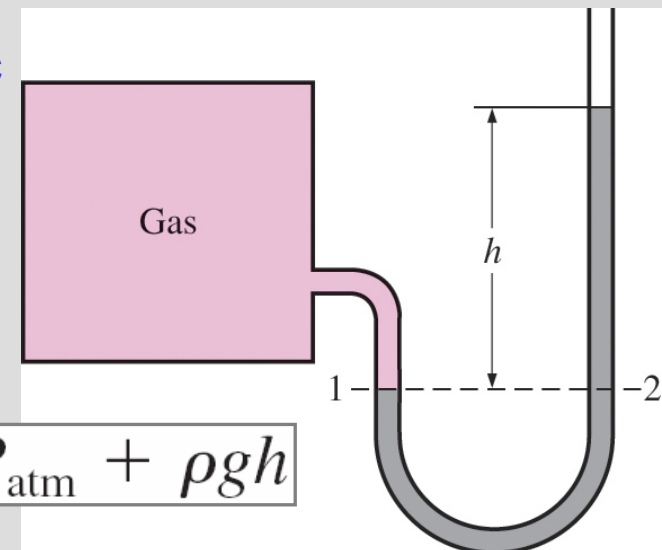

$$P_2 = P_{\text{atm}} + \rho g h$$

Quiz

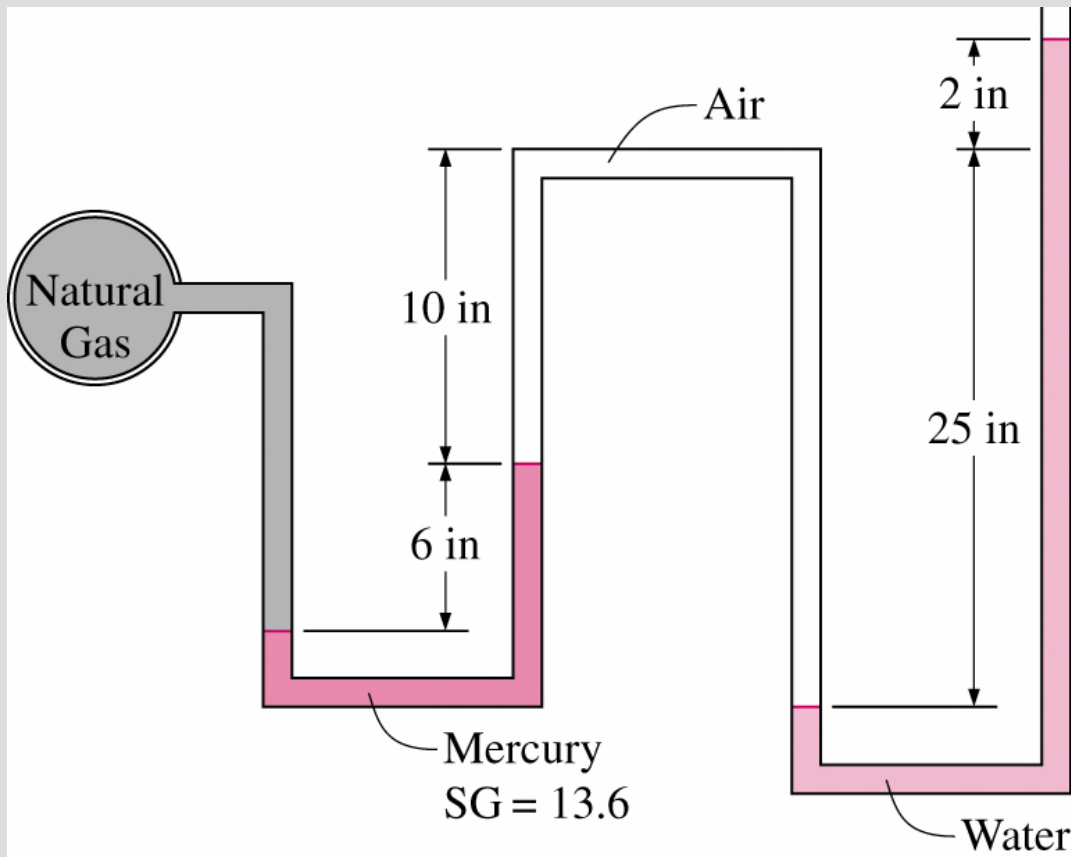

The pressure in a natural gas pipeline is measured by the manometer shown in figure with one of the arms open to the atmosphere where the local atmospheric pressure is 14.2 psia. Determine the absolute pressure in the pipeline

CLASE
HIDROSTATIC
Force on submerged surfaces

Copyright © The McGraw-Hill Companies, Inc. Permission required for reproduction or display.

Hoover Dam



Hoover Dam



- Example of elevation head z converted to velocity head $V^2/2g$. We'll discuss this in more detail in Chapter 5 (Bernoulli equation).

Hydrostatic Forces on Plane Surfaces

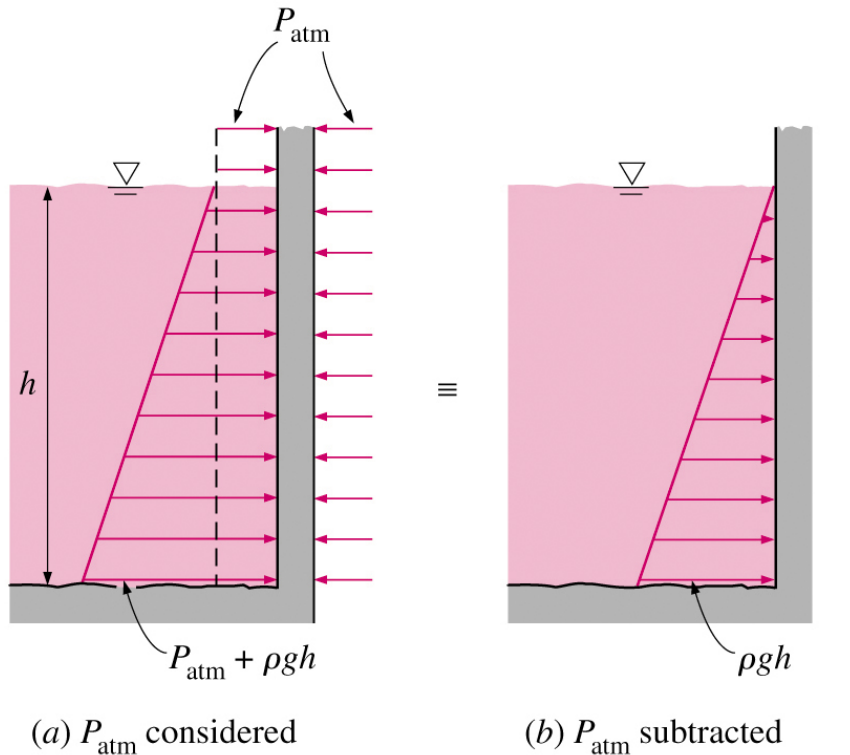

- On a *plane* surface, the hydrostatic forces form a system of parallel forces
- For many applications, magnitude and location of application, which is called **center of pressure**, must be determined.
- Atmospheric pressure P_{atm} can be neglected when it acts on both sides of the surface.

Resultant Force

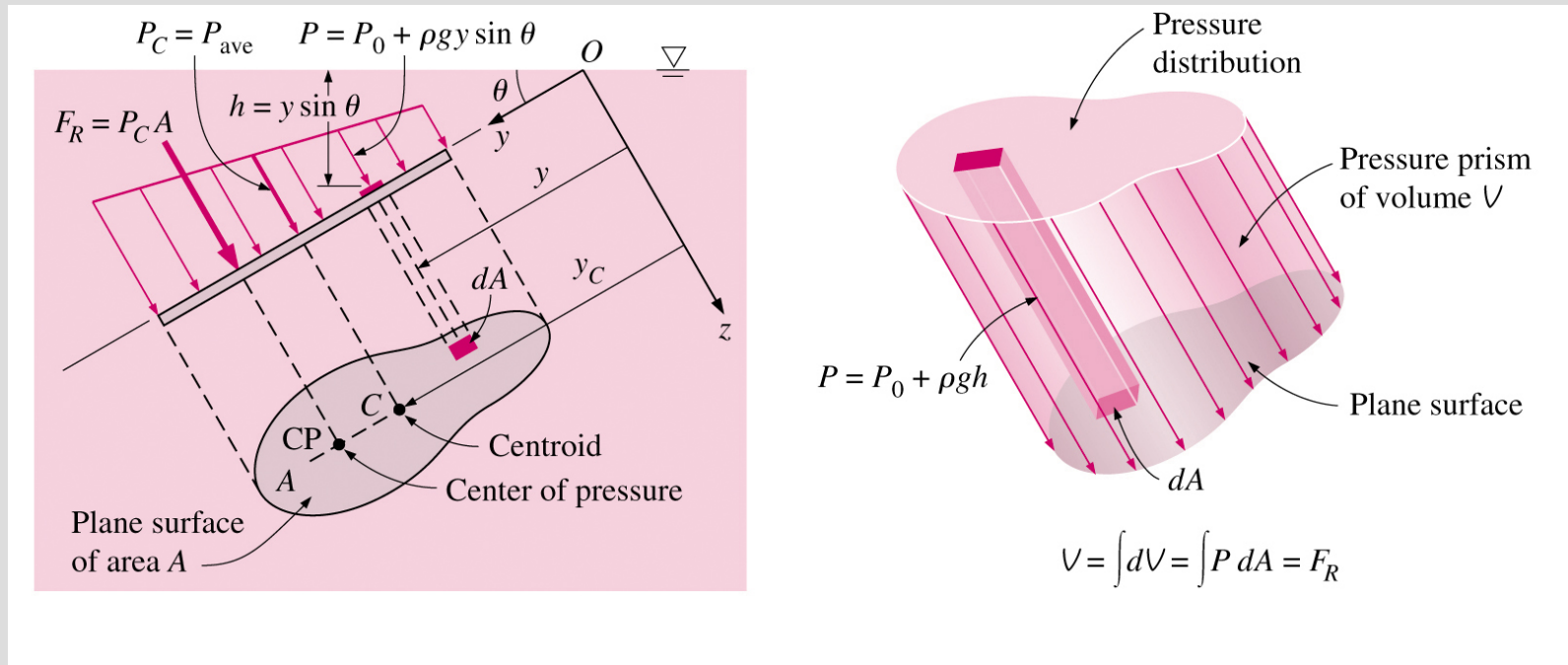

The magnitude of F_R acting on a plane surface of a completely submerged plate in a homogenous fluid is equal to the product of the pressure P_C at the centroid of the surface and the area A of the surface

Resultant Force

$$F_R = (P_0 + \rho g y_C \sin \theta)A = (P_0 + \rho g h_C)A = P_C A = P_{\text{avg}} A$$

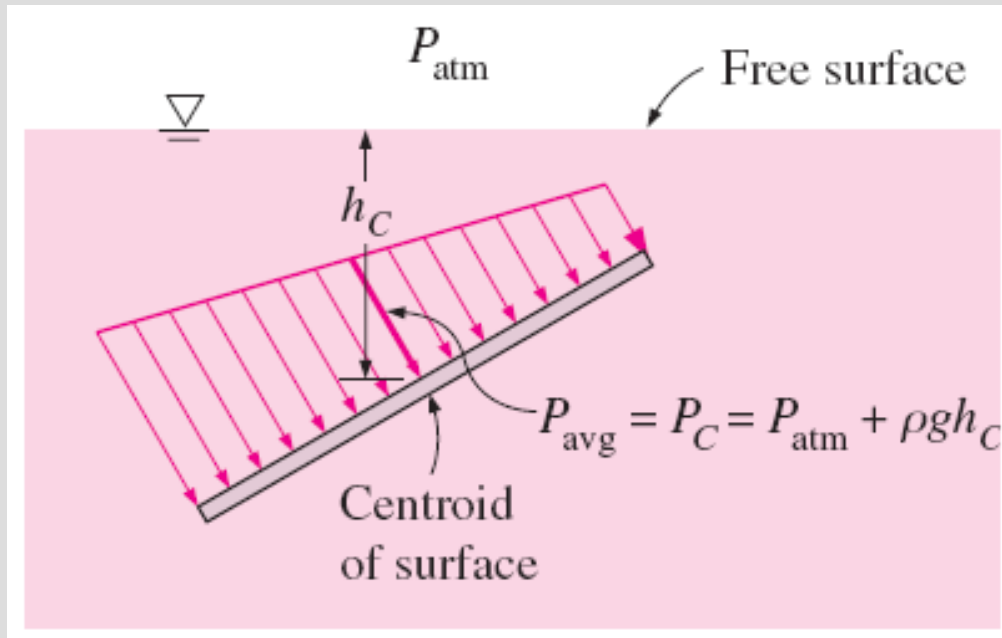

The pressure at the centroid of a surface is equivalent to the *average* pressure on the surface

Center of Pressure

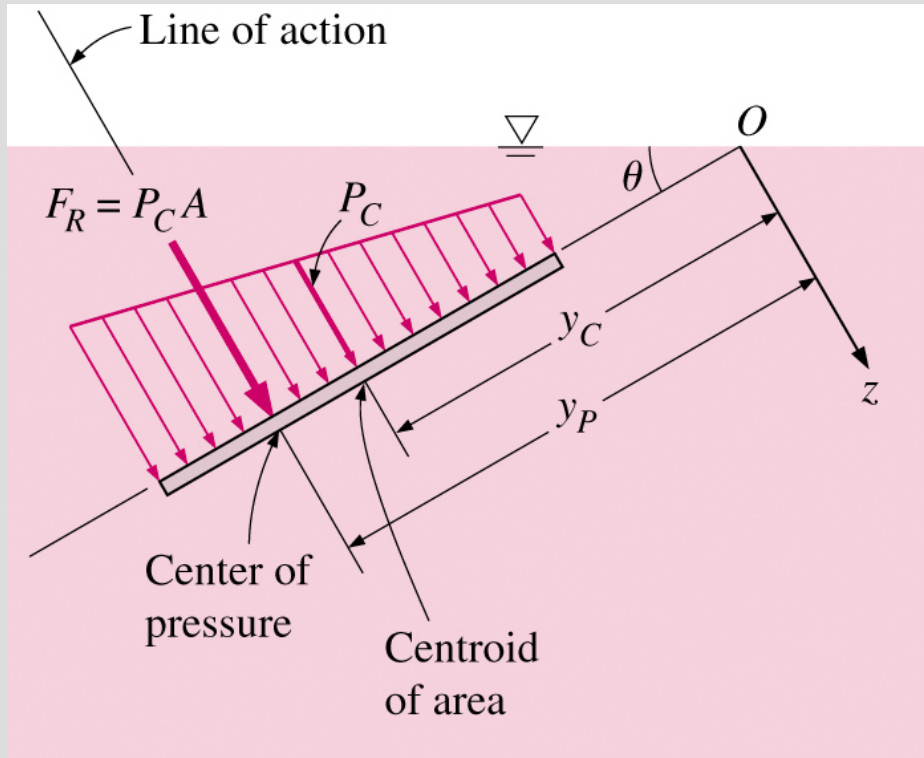

- Line of action of resultant force $F_R = P_C A$ does not pass through the centroid of the surface. In general, it lies underneath where the pressure is higher.
- Vertical location of **Center of Pressure** is determined by equating the moment of the resultant force to the moment of the distributed pressure force.

$$y_p = y_C + \frac{I_{xx,C}}{y_c A}$$

- $I_{xx,C}$ is tabulated for simple geometries.

Centroide y momento centroidal

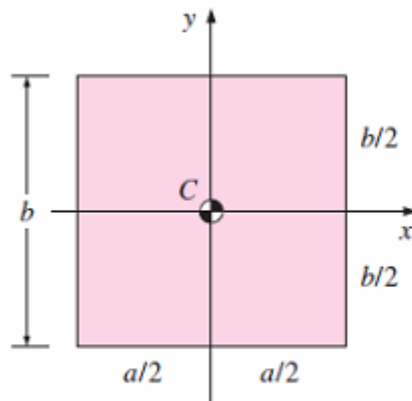

$$A = ab, I_{xx, C} = ab^3/12$$

(a) Rectangle

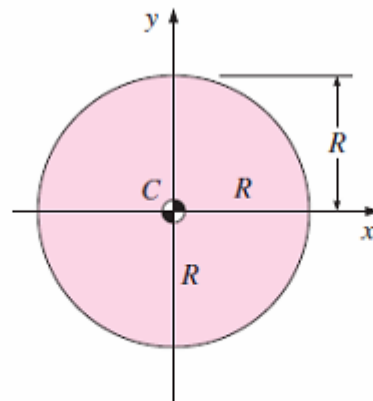

$$A = \pi R^2, I_{xx, C} = \pi R^4/4$$

(b) Circle

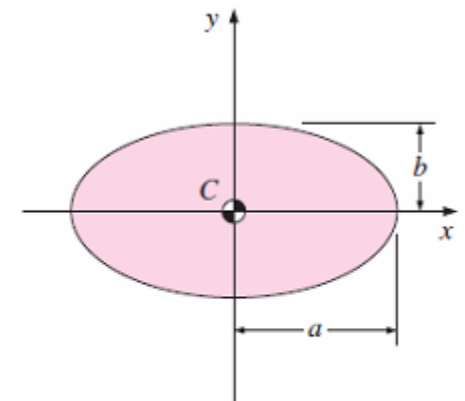

$$A = \pi ab, I_{xx, C} = \pi ab^3/4$$

(c) Ellipse

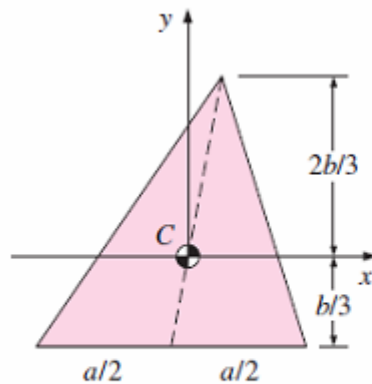

$$A = ab/2, I_{xx, C} = ab^3/36$$

(d) Triangle

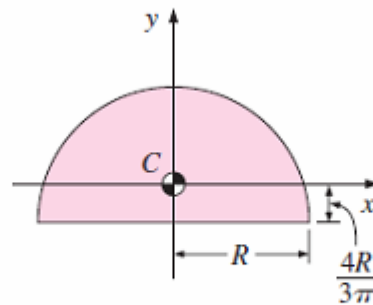

$$A = \pi R^2/2, I_{xx, C} = 0.109757R^4$$

(e) Semicircle

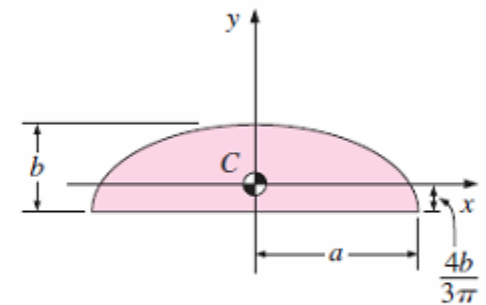

$$A = \pi ab/2, I_{xx, C} = 0.109757ab^3$$

(f) Semiellipse

Special Case: Submerged Rectangular Plate

Hydrostatic force acting on the top surface of a submerged tilted rectangular plate.

$$y_P = s + \frac{b}{2} + \frac{ab^3/12}{[s + b/2 + P_0/(\rho g \sin \theta)]ab}$$

$$= s + \frac{b}{2} + \frac{b^2}{12[s + b/2 + P_0/(\rho g \sin \theta)]}$$

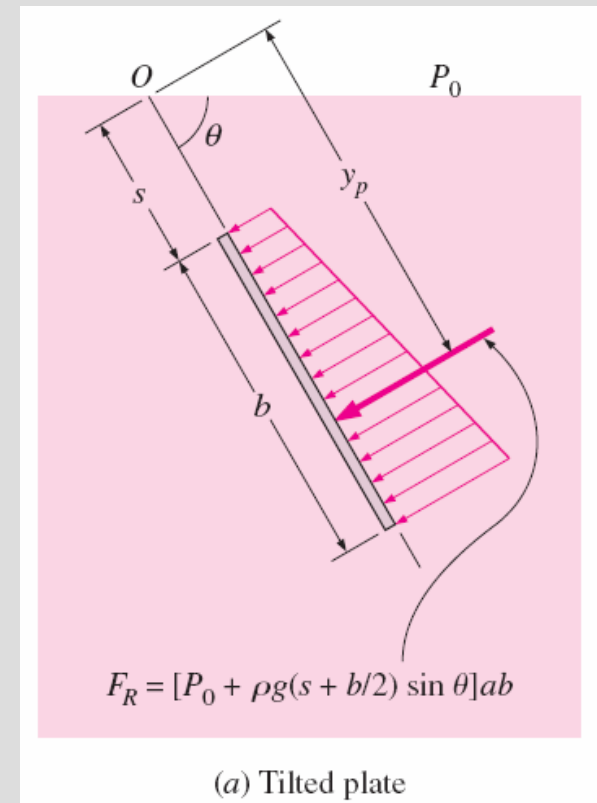

Tilted rectangular plate: $F_R = P_C A = [P_0 + \rho g(s + b/2) \sin \theta]ab$

Tilted rectangular plate ($s = 0$): $F_R = [P_0 + \rho g(b \sin \theta)/2]ab$

Special Case: Submerged Rectangular Plate

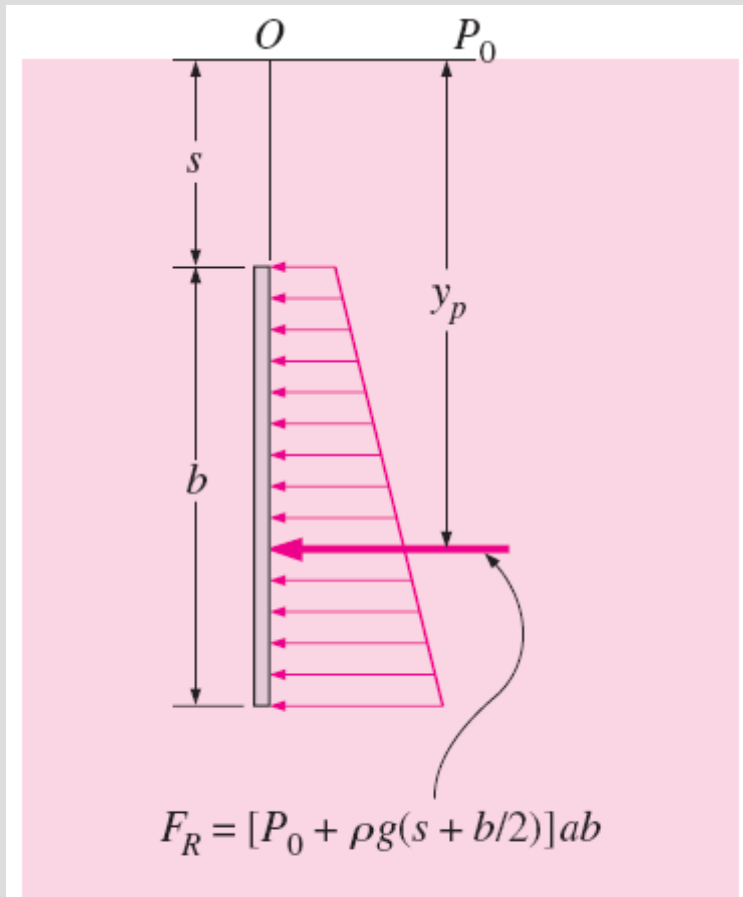

(b) Vertical plate

Hydrostatic force acting on the top surface of a submerged vertical rectangular plate.

Vertical rectangular plate:

$$F_R = [P_0 + \rho g(s + b/2)]ab$$

Vertical rectangular plate ($s = 0$):

$$F_R = (P_0 + \rho gb/2)ab$$

Special Case: Submerged Rectangular Plate

Hydrostatic force acting on the top surface of a submerged horizontal rectangular plate.

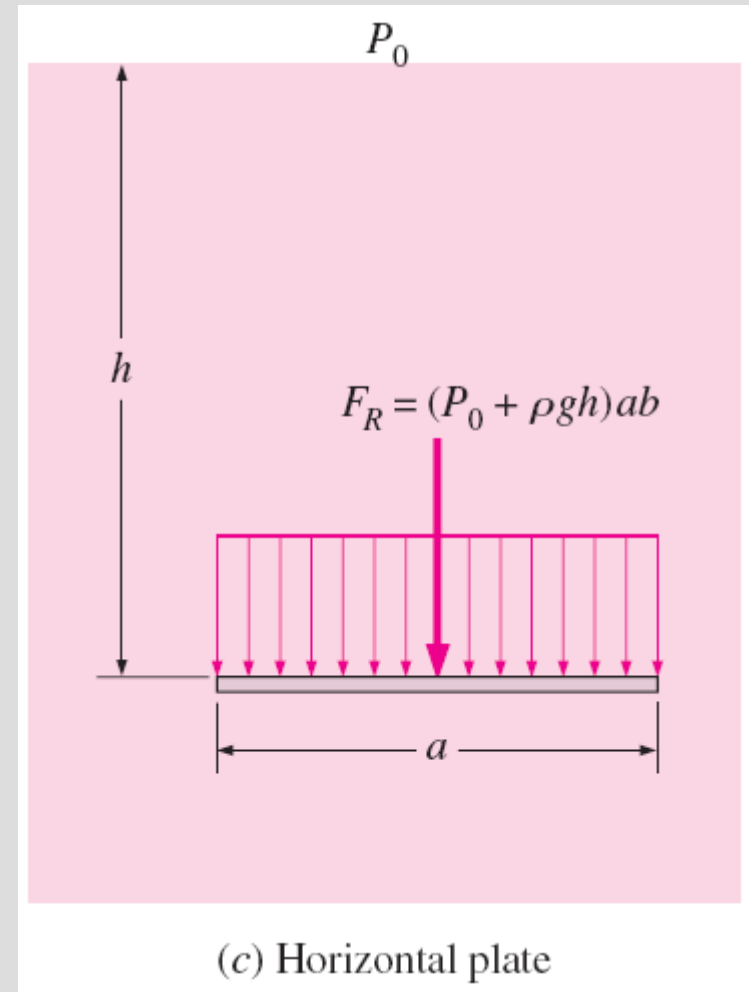

Horizontal rectangular plate: $F_R = (P_0 + \rho gh)ab$

example

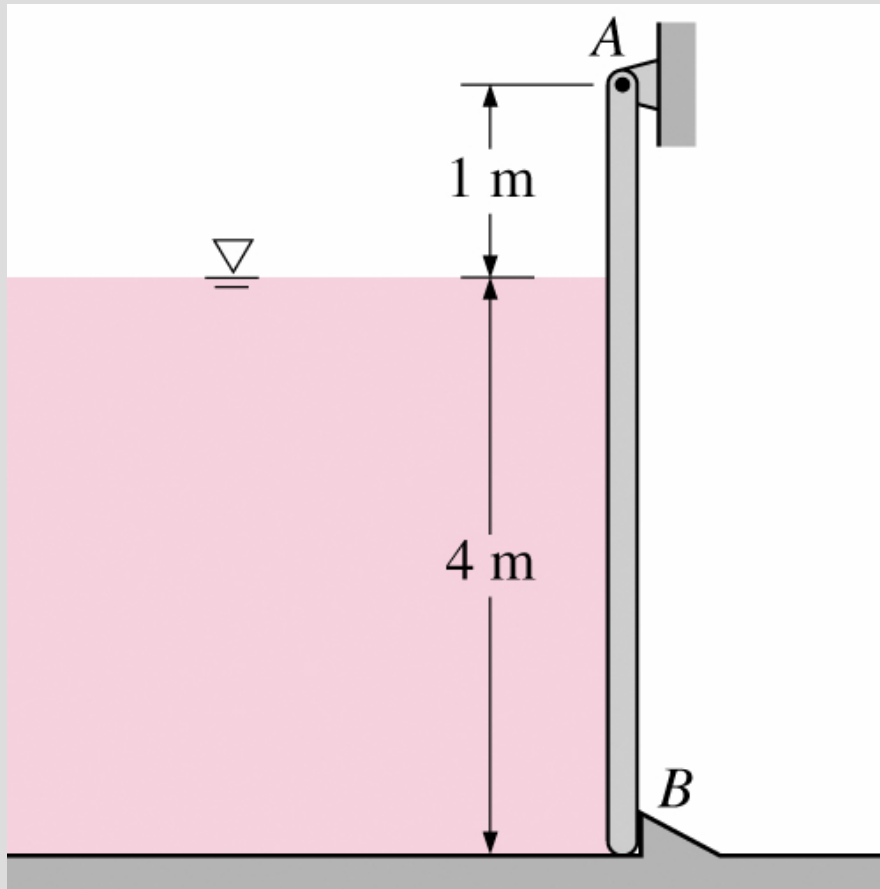

A 4 m high, 5 m wide rectangular plate blocks the end of a 4 m deep freshwater channel. The plate is hinged about a horizontal axis along its upper edge through a point A and is restrained from opening by a fixed ridge at point B. Determine the force exerted on the plate by the ridge.

Hydrostatic Forces on Curved Surfaces

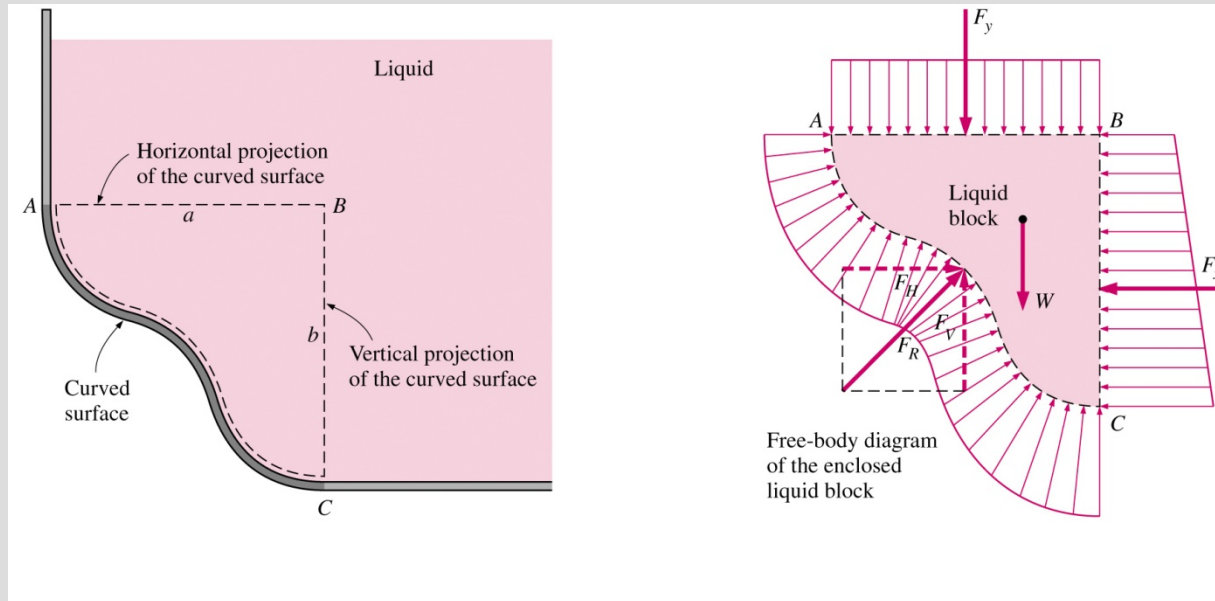

- F_R on a curved surface is more involved since it requires integration of the pressure forces that change direction along the surface.
- Easiest approach: determine horizontal and vertical components F_H and F_V separately.

Hydrostatic Forces on Curved Surfaces, example

A semicircular 30 ft diameter tunnel is to be built under a 150 ft deep, 800 ft long lake, as shown in Figure. Determine the total hydrostatic force acting on the roof of the tunnel.

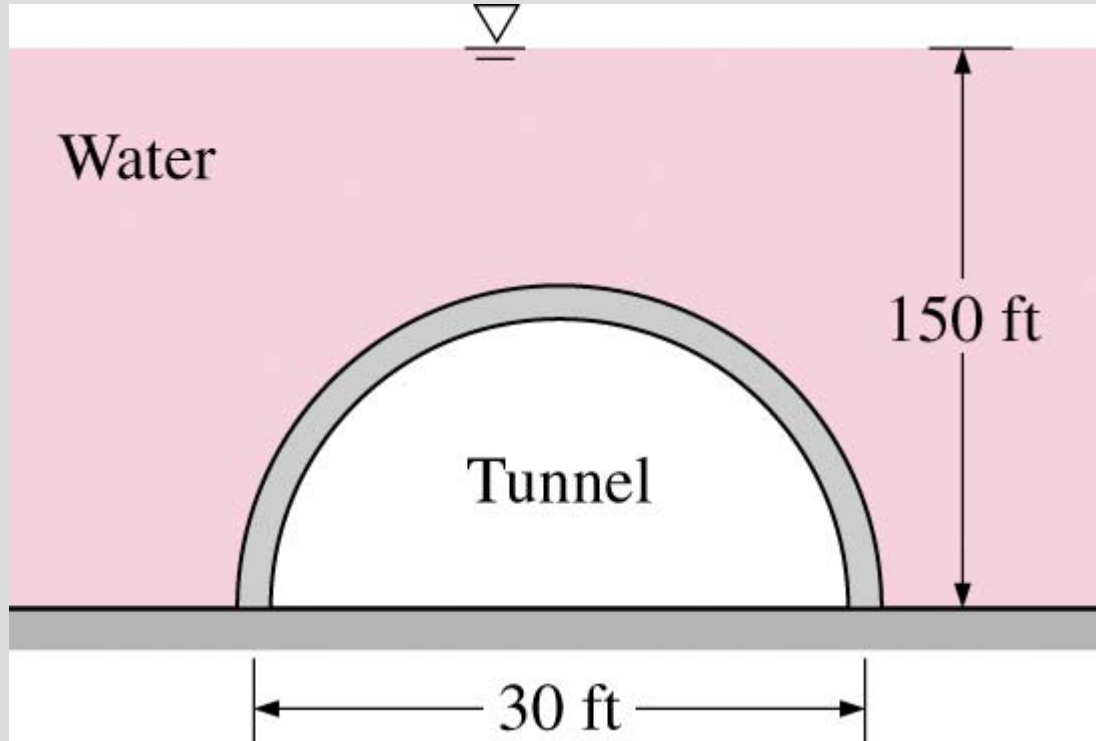

Hydrostatic Forces on Curved Surfaces, example

A semicircular 30 ft diameter tunnel is to be built under a 150 ft deep, 800 ft long lake, as shown in Figure. Determine the total hydrostatic force acting on the roof of the tunnel.

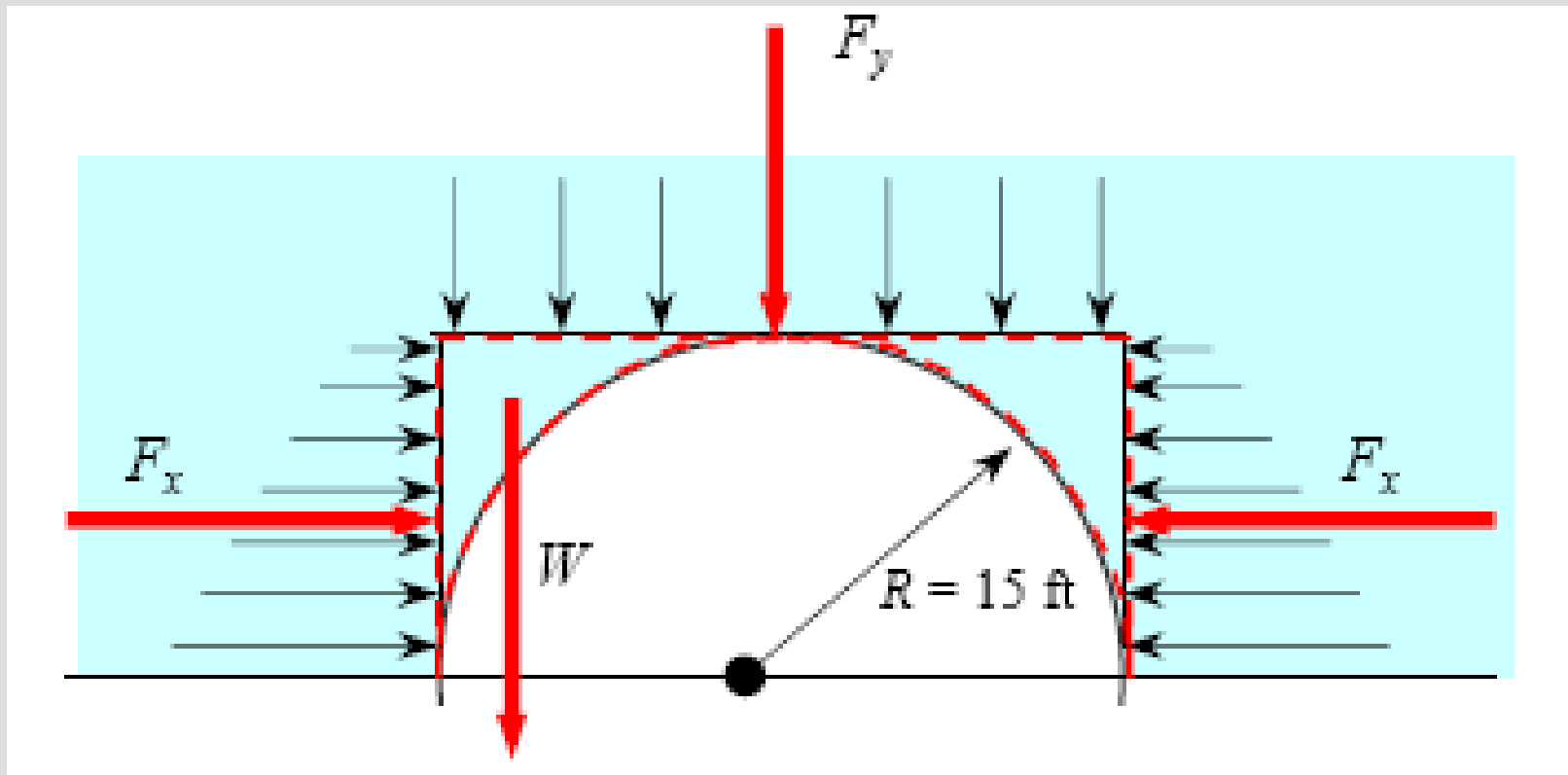

Hydrostatic Forces on Curved Surfaces

- Horizontal force component on curved surface: $F_H = F_x$.
Line of action on vertical plane gives y coordinate of center of pressure on curved surface.
- Vertical force component on curved surface: $F_V = F_y + W$,
where W is the weight of the liquid in the enclosed block
 $W = \rho g V$. x coordinate of the center of pressure is a
combination of line of action on horizontal plane
(centroid of area) and line of action through volume
(centroid of volume).
- Magnitude of force $F_R = (F_H^2 + F_V^2)^{1/2}$
- Angle of force is $\alpha = \tan^{-1}(F_V/F_H)$

CLASE

HIDROSTATIC

Buoyancy and rigid-body motion

Buoyancy and Stability

- Buoyancy is due to the fluid displaced by a body. $F_B = \rho_f g V$.
- **Archimedes principal** : The buoyant force acting on a body immersed in a fluid is equal to the weight of the fluid displaced by the body, and it acts upward through the centroid of the displaced volume.

Buoyancy and Stability

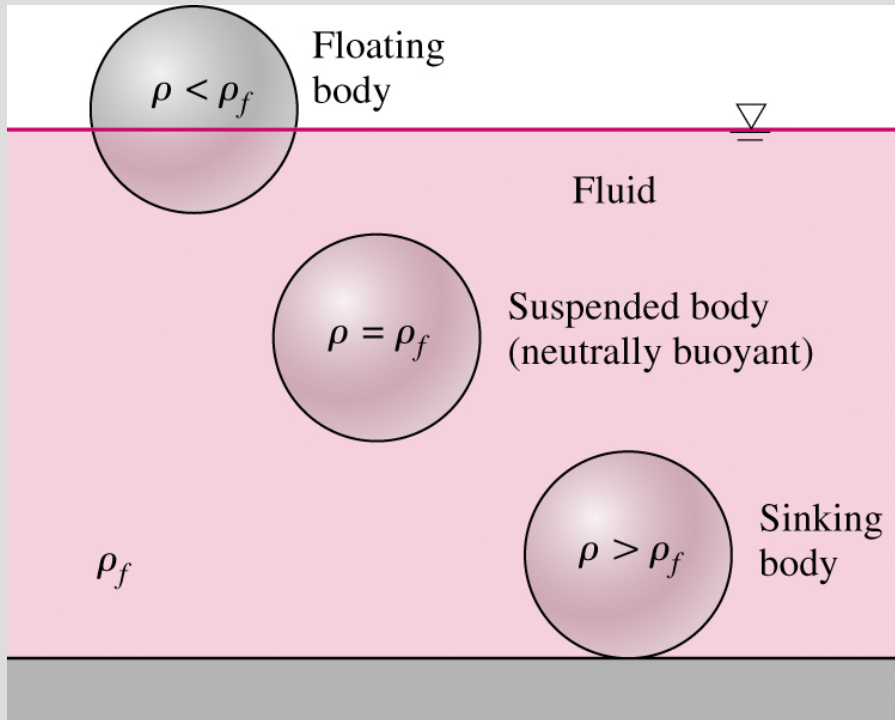

- Buoyancy force F_B is equal only to the displaced volume $\rho_f g V_{displaced}$.
- Three scenarios possible
 1. $\rho_{body} < \rho_{fluid}$: Floating body
 2. $\rho_{body} = \rho_{fluid}$: Neutrally buoyant
 3. $\rho_{body} > \rho_{fluid}$: Sinking body

Example: Galilean Thermometer

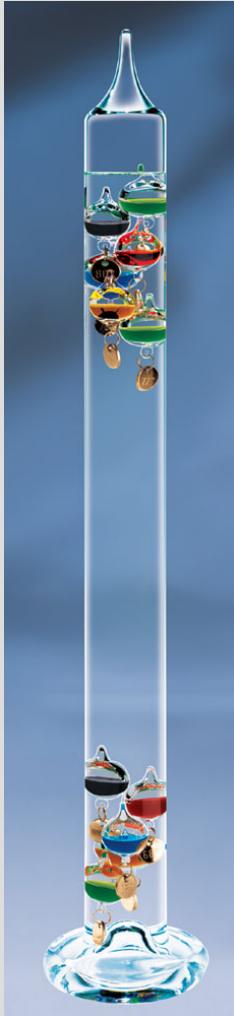

- Galileo's thermometer is made of a sealed glass cylinder containing a clear liquid.
- Suspended in the liquid are a number of weights, which are sealed glass containers with colored liquid for an attractive effect.
- As the liquid changes temperature it changes density and the suspended weights rise and fall to stay at the position where their density is equal to that of the surrounding liquid.
- If the weights differ by a very small amount and ordered such that the least dense is at the top and most dense at the bottom they can form a temperature scale.

Example: Floating Drydock

Auxiliary Floating Dry Dock Resolute (AFDM-10) partially submerged



Submarine undergoing repair work on board the AFDM-10



Using buoyancy, a submarine with a displacement of 6,000 tons can be lifted!

Example: Submarine Buoyancy and Ballast

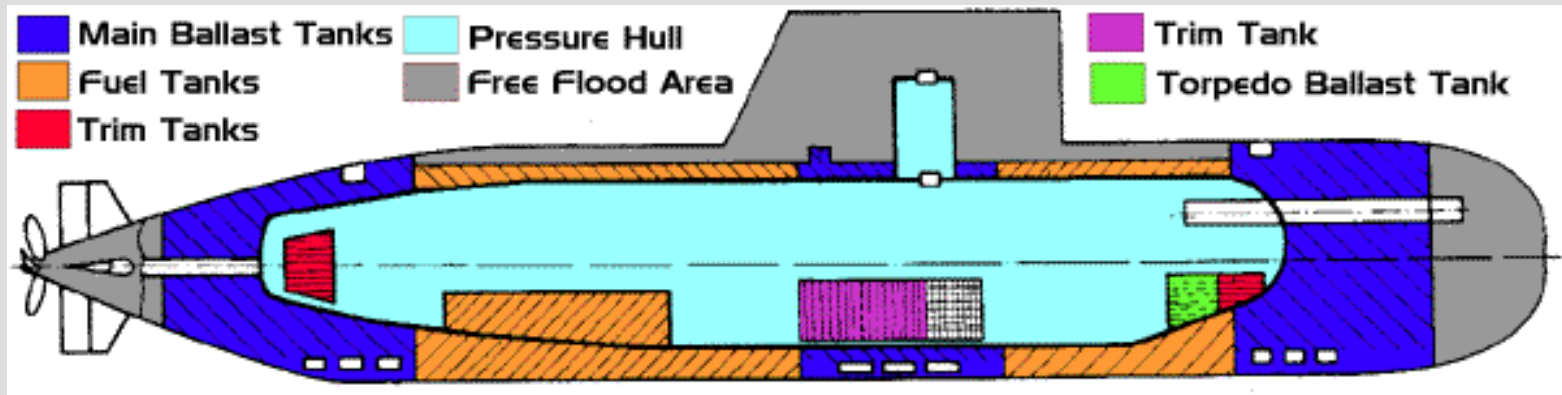

- Submarines use both static and dynamic depth control. Static control uses ballast tanks between the pressure hull and the outer hull. Dynamic control uses the bow and stern planes to generate trim forces.

Example: Submarine Buoyancy and Ballast

Normal surface trim



SSN 711 nose down after accident which damaged fore ballast tanks



Example: Submarine Buoyancy and Ballast



Damage to SSN 711 (USS San Francisco) after running aground on 8 January 2005.

Example: Submarine Buoyancy and Ballast

Ballast Control Panel: Important station for controlling depth of submarine



Stability of Immersed Bodies

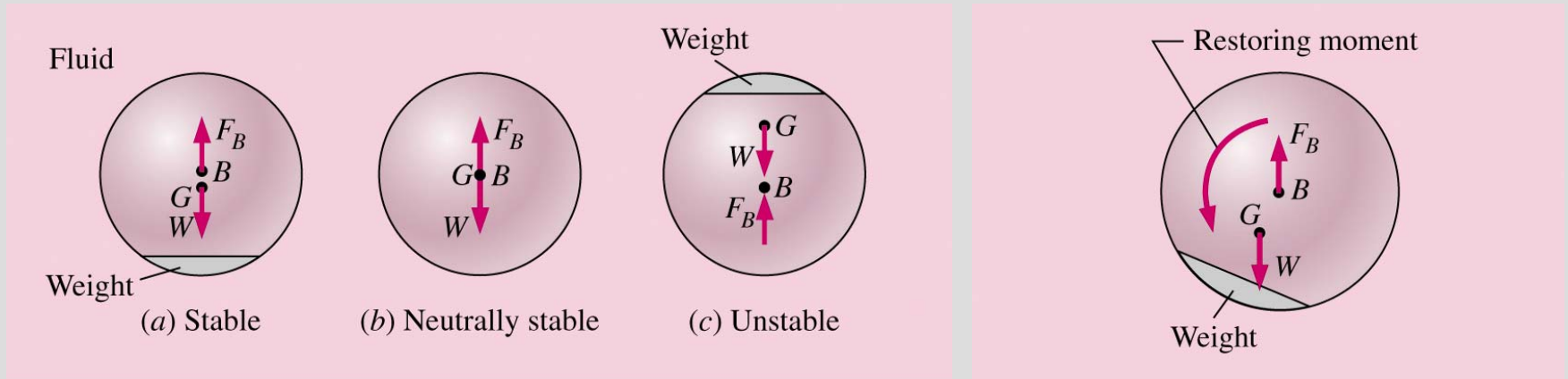

- Rotational stability of immersed bodies depends upon relative location of *center of gravity* G and *center of buoyancy* B .
 - ✓ G below B : stable
 - ✓ G above B : unstable
 - ✓ G coincides with B : neutrally stable.

Stability of Floating Bodies

- If body is bottom heavy (G lower than B), it is always stable.
- Floating bodies can be stable when G is higher than B due to shift in location of center buoyancy and creation of restoring moment.
- Measure of stability is the metacentric height GM . If $GM > 0$, ship is stable.

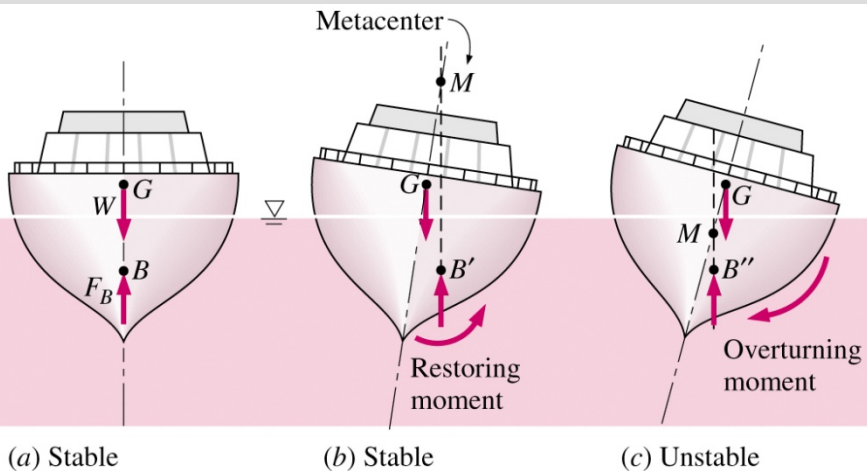

Rigid-Body Motion

- There are special cases where a body of fluid can undergo rigid-body motion: linear acceleration, and rotation of a cylindrical container.

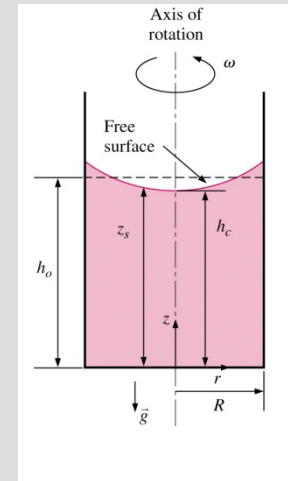
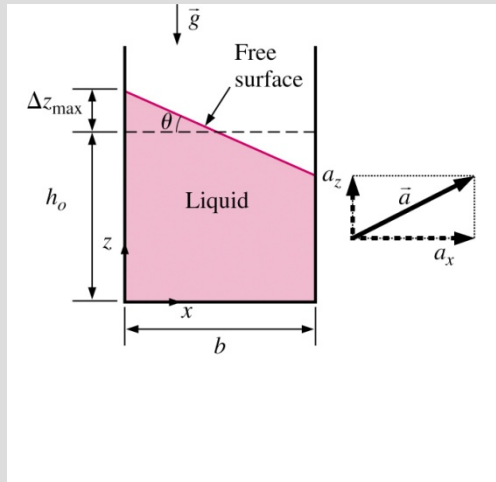

- In these cases, no shear is developed.
- Newton's 2nd law of motion can be used to derive an **equation of motion** for a fluid that acts as a rigid body

$$\nabla P + \rho g \vec{k} = -\rho \vec{a}$$

- In Cartesian coordinates: $\frac{\partial P}{\partial x} = -\rho a_x, \frac{\partial P}{\partial y} = -\rho a_y, \frac{\partial P}{\partial z} = -\rho(g + a_z)$

Linear Acceleration



Container is moving on a straight path

$$a_x \neq 0, a_y = a_z = 0$$

$$\frac{\partial P}{\partial x} = \rho a_x, \frac{\partial P}{\partial y} = 0, \frac{\partial P}{\partial z} = -\rho g$$

Total differential of P

$$dP = -\rho a_x dx - \rho g dz$$

Pressure difference between 2 points

$$P_2 - P_1 = -\rho a_x (x_2 - x_1) - \rho g (z_2 - z_1)$$

Find the rise by selecting 2 points on free surface $P_2 = P_1$

$$\Delta z_s = z_{s2} - z_{s1} = -\frac{a_x}{g} (x_2 - x_1)$$

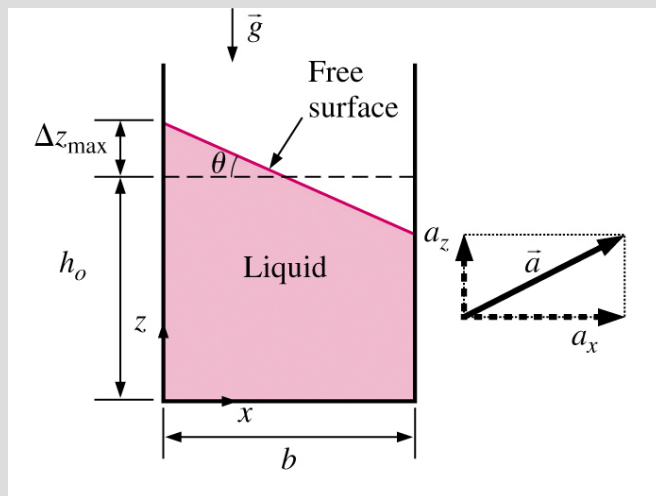

Rotation in a Cylindrical Container

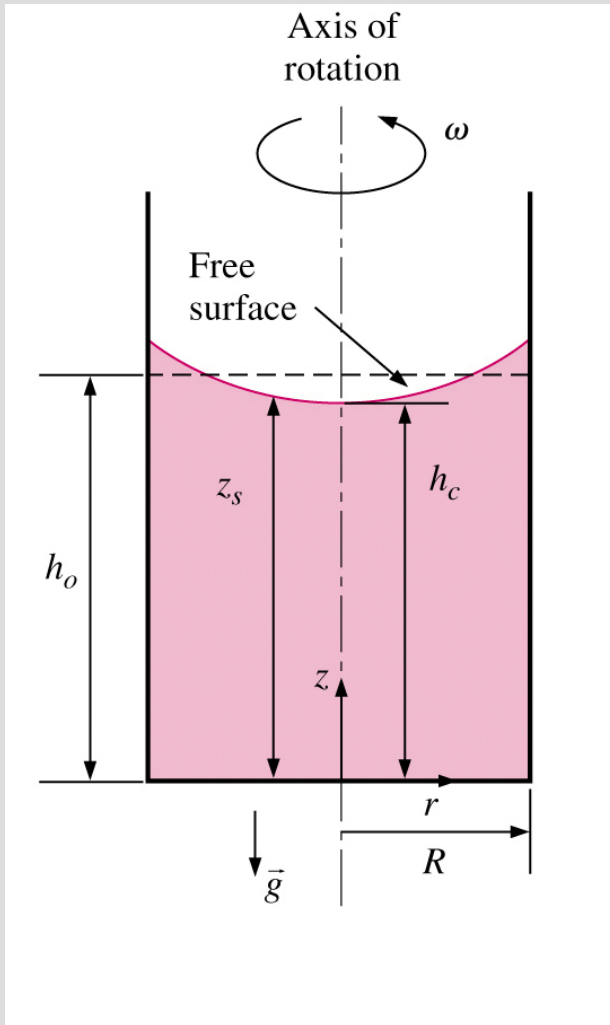

Container is rotating about the z-axis

$$a_r = -r\omega^2, a_\theta = a_z = 0$$

$$\frac{\partial P}{\partial r} = \rho r\omega^2, \frac{\partial P}{\partial \theta} = 0, \frac{\partial P}{\partial z} = -\rho g$$

Total differential of P

$$dP = \rho r\omega^2 dr - \rho g dz$$

On an isobar, $dP = 0$

$$\frac{dz_{isobar}}{dr} = \frac{r\omega^2}{g} \rightarrow z_{isobar} = \frac{\omega^2}{2g} r^2 + C_1$$

Equation of the free surface

$$z_s = h_0 - \frac{\omega^2}{4g} (R^2 - 2r^2)$$

Examples of Archimedes Principle

The Golden Crown of Hiero II, King of Syracuse

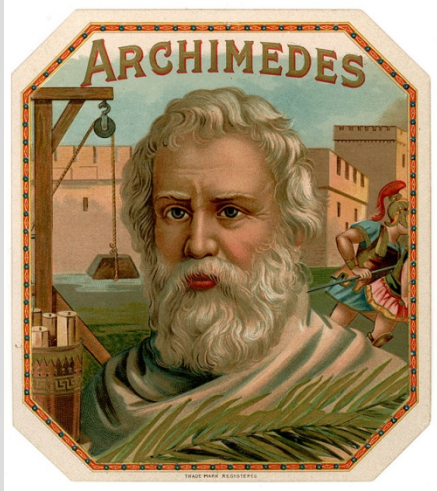

- Archimedes, 287-212 B.C.
- Hiero, 306-215 B.C.
- Hiero learned of a rumor where the goldsmith replaced some of the gold in his crown with silver. Hiero asked Archimedes to determine whether the crown was pure gold.
- Archimedes had to develop a nondestructive testing method



The Golden Crown of Hiero II, King of Syracuse



- The weight of the crown and nugget are the same in air: $W_c = \rho_c V_c = W_n = \rho_n V_n$.
- If the crown is pure gold, $\rho_c = \rho_n$ which means that the volumes must be the same, $V_c = V_n$.
- In water, the buoyancy force is $B = \rho_{H_2O} V$.
- If the scale becomes unbalanced, this implies that the $V_c \neq V_n$, which in turn means that the $\rho_c \neq \rho_n$.
- Goldsmith was shown to be a fraud!

Hydrostatic Bodyfat Testing



- What is the best way to measure body fat?
- Hydrostatic Bodyfat Testing using Archimedes Principle!
- Process
 - ✓ Measure body weight $W = \rho_{body} V$
 - ✓ Get in tank, expel all air, and measure apparent weight W_a
 - ✓ Buoyancy force $B = W - W_a = \rho_{H_2O} V$. This permits computation of body volume.
 - ✓ Body density can be computed $\rho_{body} = W/V$.
 - ✓ Body fat can be computed from formulas.

Hydrostatic Bodyfat Testing in Air?



- Same methodology as Hydrostatic testing in water.
- What are the ramifications of using air?
 - ✓ Density of air is 1/1000th of water.
 - ✓ Temperature dependence of air.
 - ✓ Measurement of small volumes.
 - ✓ Used by NCAA Wrestling (there is a BodPod on PSU campus).