

CLASS

Fourth Units (First part)

Overview

- Fluid Kinematics deals with the motion of fluids without considering the forces and moments which create the motion.
- Items discussed in this Chapter.
 - ✓ Material derivative and its relationship to Lagrangian and Eulerian descriptions of fluid flow.
 - ✓ Fundamental kinematic properties of fluid motion and deformation.
 - ✓ Reynolds Transport Theorem

Lagrangian Description

- Lagrangian description of fluid flow tracks the position and velocity of individual particles.
- Based upon Newton's laws of motion.
- Difficult to use for practical flow analysis.
 - ✓ Fluids are composed of *billions* of molecules.
 - ✓ Interaction between molecules hard to describe/model.
- However, useful for specialized applications
 - ✓ Sprays, particles, bubble dynamics, rarefied gases.
 - ✓ Coupled Eulerian-Lagrangian methods.
- Named after Italian mathematician Joseph Louis Lagrange (1736-1813).

Eulerian Description

- Eulerian description of fluid flow: a **flow domain** or **control volume** is defined by which fluid flows in and out.
- We define **field variables** which are functions of space and time.
 - ✓ Pressure field, $P=P(x,y,z,t)$
 - ✓ Velocity field, $\vec{V} = \vec{V}(x, y, z, t)$
$$\vec{V} = u(x, y, z, t)\vec{i} + v(x, y, z, t)\vec{j} + w(x, y, z, t)\vec{k}$$
 - ✓ Acceleration field, $\vec{a} = \vec{a}(x, y, z, t)$
$$\vec{a} = a_x(x, y, z, t)\vec{i} + a_y(x, y, z, t)\vec{j} + a_z(x, y, z, t)\vec{k}$$
 - ✓ These (and other) field variables define the **flow field**.
- Well suited for formulation of initial boundary-value problems (PDE's).
- Named after Swiss mathematician Leonhard Euler (1707-1783).

Example: Coupled Eulerian-Lagrangian Method



- Global Environmental MEMS Sensors (GEMS)
- Simulation of micron-scale airborne probes. The probe positions are tracked using a Lagrangian particle model embedded within a flow field computed using an Eulerian CFD code.

http://www.ensco.com/products/atmospheric/gem/gem_ovr.htm

Example: Coupled Eulerian-Lagrangian Method

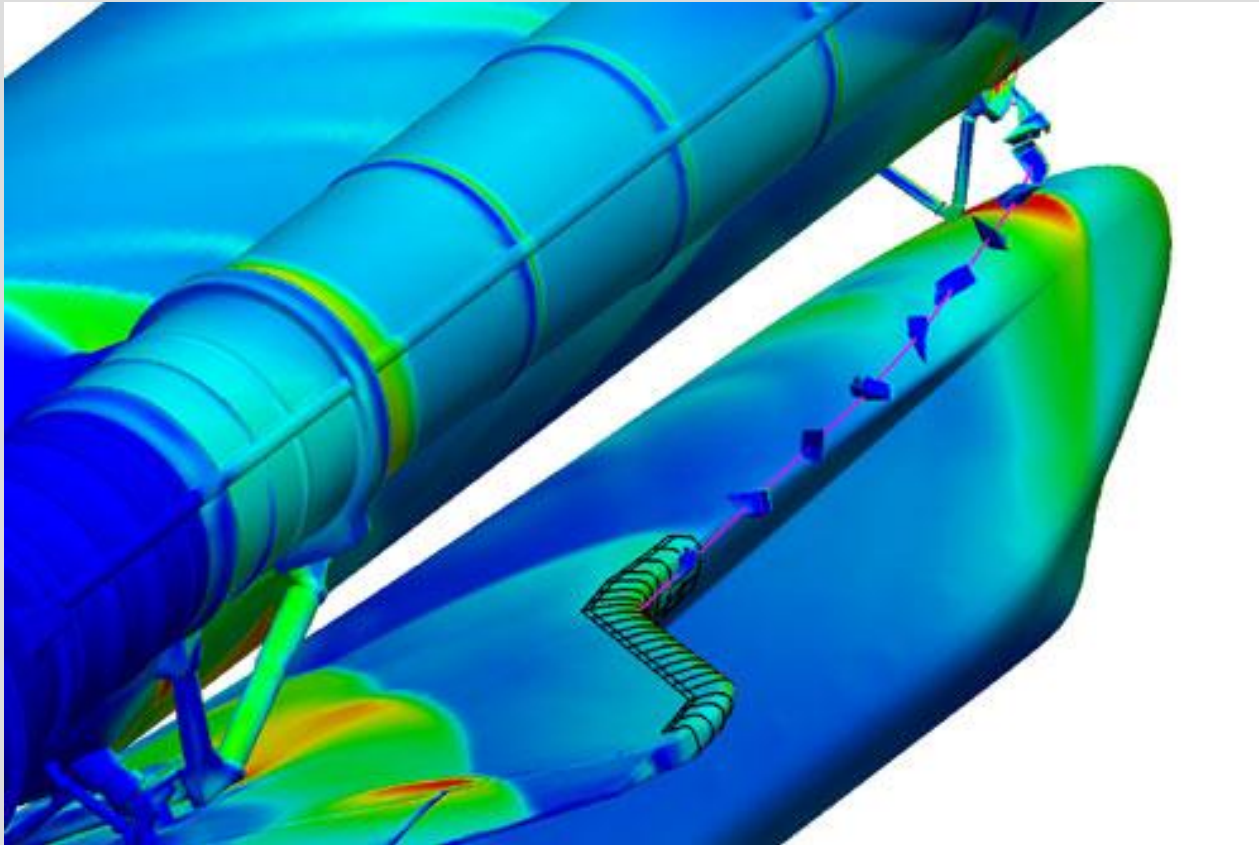

Forensic analysis of Columbia accident: simulation of shuttle debris trajectory using Eulerian CFD for flow field and Lagrangian method for the debris.

A Steady Two-Dimensional Velocity Field

Consider the following steady, two-dimensional velocity field:

$$\vec{V} = (u, v) = \left[a^2 - (b - cx)^2 \right] \vec{i} + \left(-2cby + 2c^2xy \right) \vec{j}$$

Is there a stagnation point in this flow field? If so, where is it?

Acceleration Field

- Consider a fluid particle and Newton's second law

$$\vec{F}_{particle} = m_{particle} \vec{a}_{particle}$$

- The acceleration of the particle is the time derivative of the particle's velocity.

$$\vec{a}_{particle} = \frac{d\vec{V}_{particle}}{dt}$$

- However, particle velocity at a point is the same as the fluid velocity,

$$\vec{V}_{particle} = \vec{V}(x_{particle}(t), y_{particle}(t), z_{particle}(t))$$

- To take the time derivative of, chain rule must be used.

$$\vec{a}_{particle} = \frac{\partial \vec{V}}{\partial t} \frac{dt}{dt} + \frac{\partial \vec{V}}{\partial x} \frac{dx_{particle}}{dt} + \frac{\partial \vec{V}}{\partial y} \frac{dy_{particle}}{dt} + \frac{\partial \vec{V}}{\partial z} \frac{dz_{particle}}{dt}$$

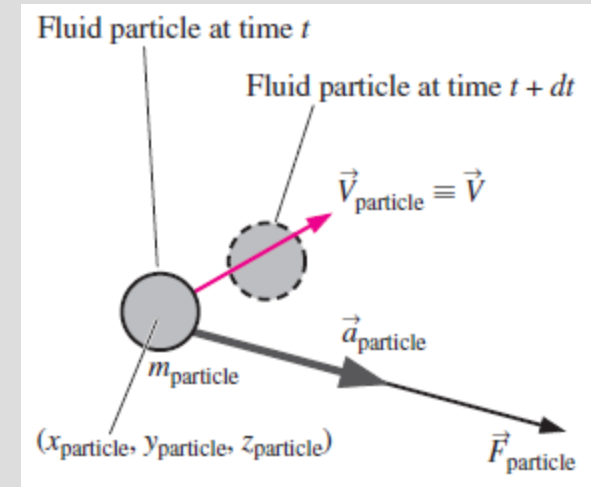

Acceleration Field

- Since $\frac{dx_{particle}}{dt} = u, \frac{dy_{particle}}{dt} = v, \frac{dz_{particle}}{dt} = w$

$$\vec{a}_{particle} = \frac{\partial \vec{V}}{\partial t} + u \frac{\partial \vec{V}}{\partial x} + v \frac{\partial \vec{V}}{\partial y} + w \frac{\partial \vec{V}}{\partial z}$$

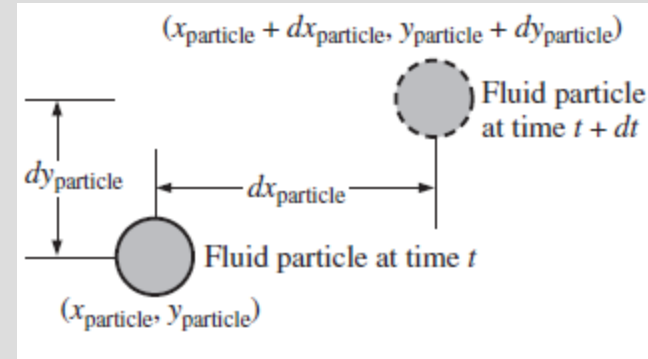

- In vector form, the acceleration can be written as

$$\vec{a}(x, y, z, t) = \frac{d\vec{V}}{dt} = \frac{\partial \vec{V}}{\partial t} + (\vec{V} \bullet \vec{\nabla}) \vec{V}$$

- First term is called the **local acceleration** and is nonzero only for unsteady flows.
- Second term is called the **advective acceleration** and accounts for the effect of the fluid particle moving to a new location in the flow, where the velocity is different.

Nabla

En geometría diferencial, **nabla** (también llamado **del**) es un operador diferencial representado por el símbolo: ∇ (nabla). En coordenadas cartesianas tridimensionales, nabla se puede escribir como:

$$\nabla = \hat{x} \frac{\partial}{\partial x} + \hat{y} \frac{\partial}{\partial y} + \hat{z} \frac{\partial}{\partial z}.$$

siendo \hat{x}, \hat{y} y \hat{z} los vectores unitarios en las direcciones de los ejes coordenados. Esta base también se representa por $\vec{i}, \vec{j}, \vec{k}$.

Aplicaciones del operador nabla

Este operador puede aplicarse a campos escalares (Φ) o a campos vectoriales \mathbf{F} , dando:

- Gradiente: $\nabla \phi$
- Divergencia: $\nabla \cdot \vec{F}$
- Rotacional: $\nabla \times \vec{F}$
- Laplaciano: $\nabla^2 \phi = \nabla \cdot (\nabla \phi)$

Material Derivative

$$\frac{D\vec{V}}{Dt} = \frac{d\vec{V}}{dt} = \frac{\partial\vec{V}}{\partial t} + (\vec{V} \cdot \nabla)\vec{V}$$

The total derivative operator d/dt in this equation is given a special name, the **material derivative**; it is assigned a special notation, D/Dt , in order to emphasize that it is formed by *following a fluid particle as it moves through the flow field*.

Other names for the material derivative include **total**, **particle**, **Lagrangian**, **Eulerian**, and **substantial derivative**.

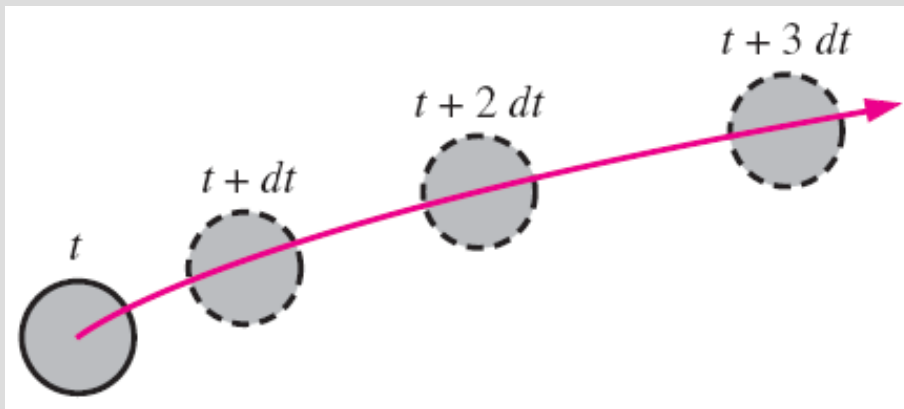

The material derivative D/Dt is defined by following a fluid particle as it moves throughout the flow field. In this illustration, the fluid particle is accelerating to the right as it moves up and to the right.

Material derivative: $\frac{D}{Dt} = \frac{d}{dt} = \frac{\partial}{\partial t} + (\vec{V} \cdot \vec{\nabla})$

Material acceleration: $\vec{a}(x, y, z, t) = \frac{D\vec{V}}{Dt} = \frac{d\vec{V}}{dt} = \frac{\partial\vec{V}}{\partial t} + (\vec{V} \cdot \vec{\nabla})\vec{V}$

Material derivative of pressure: $\frac{DP}{Dt} = \frac{dP}{dt} = \frac{\partial P}{\partial t} + (\vec{V} \cdot \vec{\nabla})P$

$$\underbrace{\frac{D}{Dt}}_{\text{Material derivative}} = \underbrace{\frac{\partial}{\partial t}}_{\text{Local}} + \underbrace{(\vec{V} \cdot \vec{\nabla})}_{\text{Advective}}$$

The material derivative D/Dt is composed of a *local* or *unsteady* part and a *convective* or *advective* part.

Problem:

Consider the steady, incompressible, two-dimensional velocity field:

$$\vec{V} = (u, v) = (0.5 + 0.8x)\vec{i} + (1.5 - 0.8y)\vec{j}$$

- a) Calculate the material acceleration at the point $(x = 2\text{m}, y = 3\text{m})$.
- b) Sketch the material acceleration vectors at several locations in the domain between $x = -2\text{m}$ to 2m and $y = 0\text{m}$ to 5m ; qualitatively describe the flow field.

Problem:

Nadeen is washing her car, using a nozzle similar to the one sketched in Fig. 4–8. The nozzle is 3.90 in (0.325 ft) long, with an inlet diameter of 0.420 in (0.0350 ft) and an outlet diameter of 0.182 in (see Fig. 4–9). The volume flow rate through the garden hose (and through the nozzle) is $\dot{V} = 0.841$ gal/min (0.00187 ft³/s), and the flow is steady. Estimate the magnitude of the acceleration of a fluid particle moving down the centerline of the nozzle.

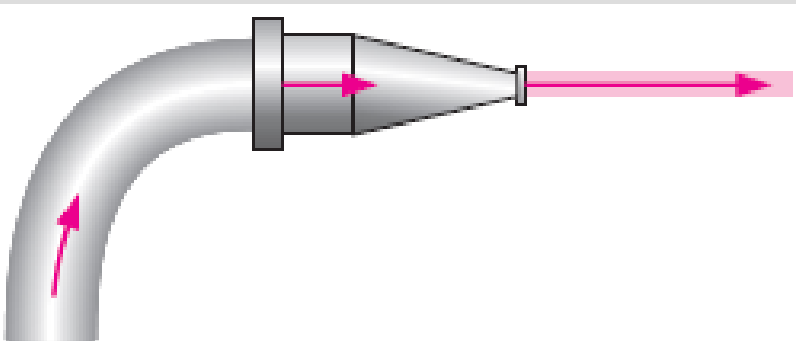

FIGURE 4–8

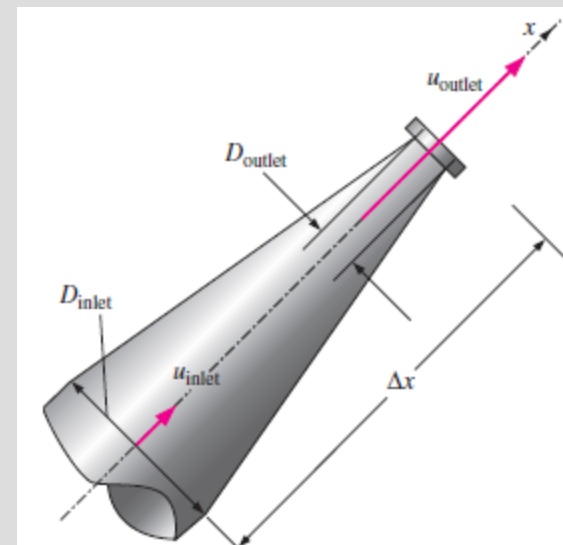
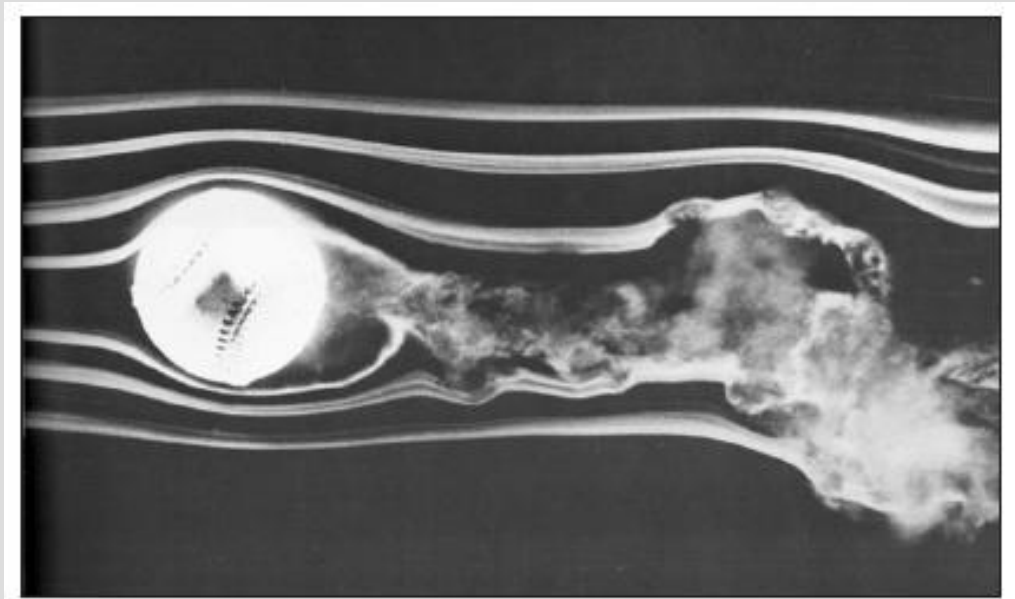

FIGURE 4–9

FLOW PATTERNS AND FLOW VISUALIZATION

- **Flow visualization:** The visual examination of flow field features.
- While quantitative study of fluid dynamics requires advanced mathematics, much can be learned from flow visualization.
- Flow visualization is useful not only in physical experiments but in *numerical* solutions as well [computational fluid dynamics (CFD)].
- In fact, the very first thing an engineer using CFD does after obtaining a numerical solution is simulate some form of flow visualization.



Spinning baseball. The late F. N. M. Brown devoted many years to developing and using smoke visualization in wind tunnels at the University of Notre Dame. Here the flow speed is about 23 m/s and the ball is rotated at 630 rpm.

Flow Visualization

- Flow visualization is the visual examination of flow-field features.
- Important for both physical experiments and numerical (CFD) solutions.
- Numerous methods
 - ✓ Streamlines and streamtubes
 - ✓ Pathlines
 - ✓ Streaklines
 - ✓ Refractive techniques
 - ✓ Surface flow techniques

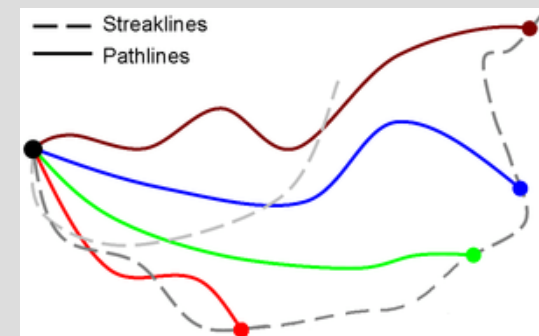
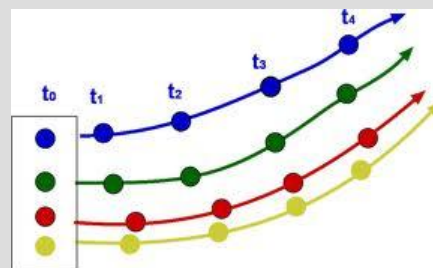
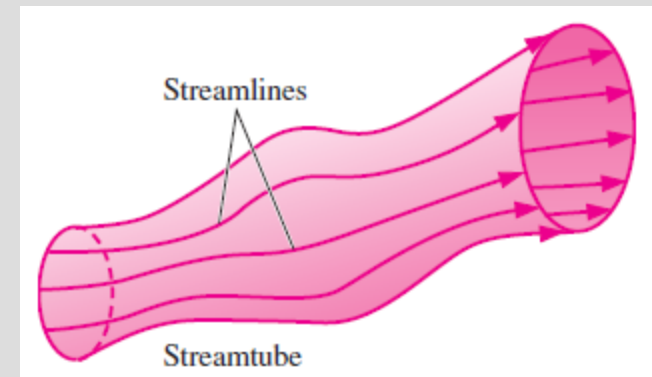

Pathlines

Streamlines

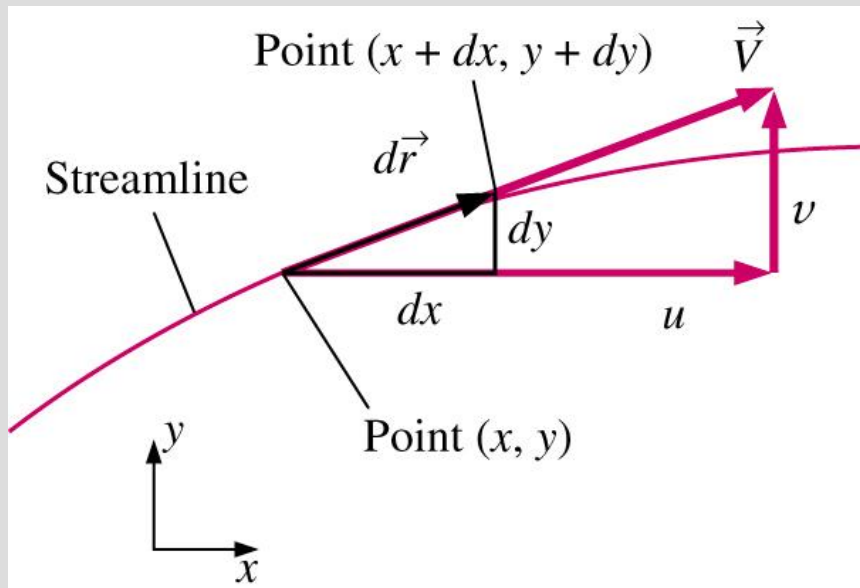

- A **Streamline** is a curve that is everywhere tangent to the *instantaneous* local velocity vector.
- Consider an arc length
$$d\vec{r} = dx\vec{i} + dy\vec{j} + dz\vec{k}$$
- $d\vec{r}$ must be parallel to the local velocity vector

$$\vec{V} = u\vec{i} + v\vec{j} + w\vec{k}$$

- Geometric arguments results in the equation for a streamline

$$\frac{dr}{V} = \frac{dx}{u} = \frac{dy}{v} = \frac{dz}{w}$$

Streamlines

NASCAR surface pressure contours and streamlines

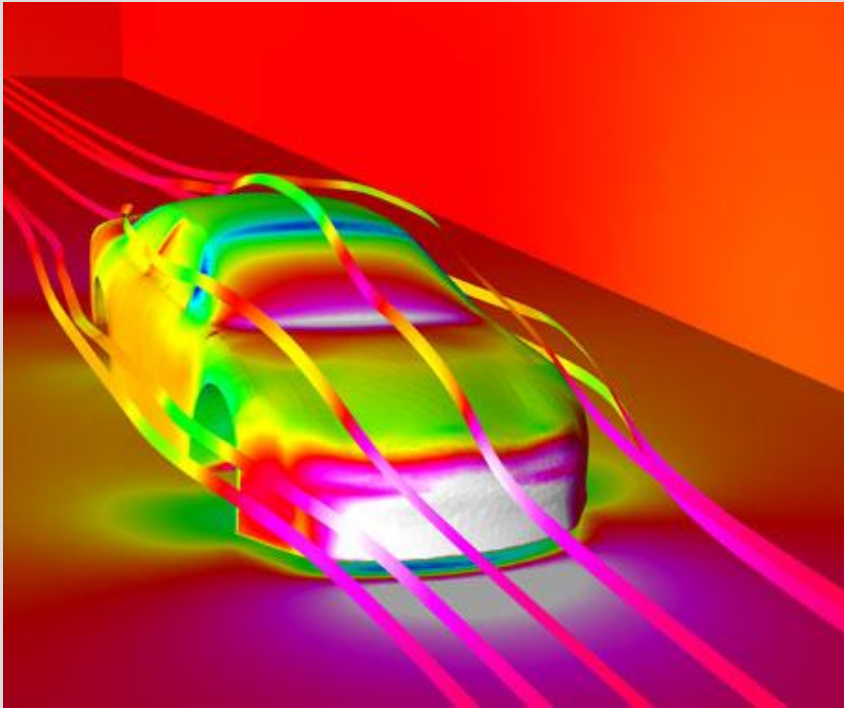

Airplane surface pressure contours, volume streamlines, and surface streamlines

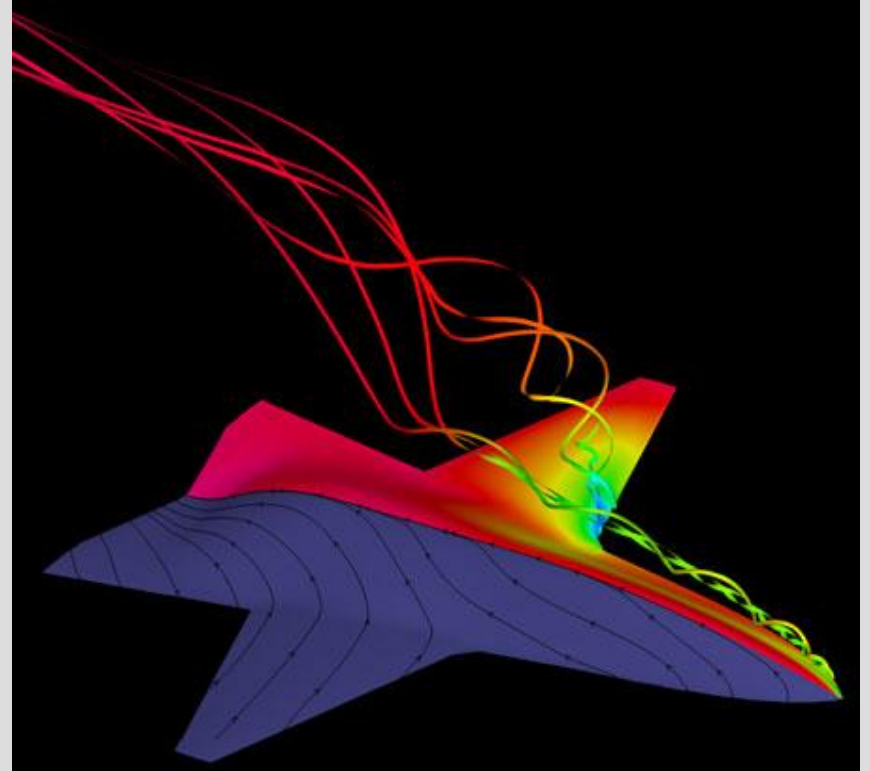

Pathlines

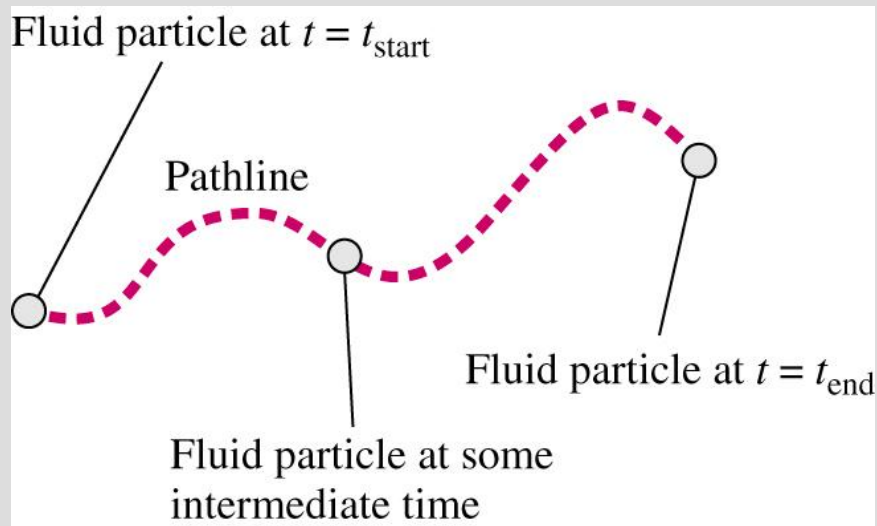

- A **Pathline** is the actual path traveled by an individual fluid particle over some time period.

- Same as the fluid particle's material position vector $(x_{particle}(t), y_{particle}(t), z_{particle}(t))$

- Particle location at time t :

$$\vec{x} = \vec{x}_{start} + \int_{t_{start}}^t \vec{V} dt$$

- Particle Image Velocimetry (PIV) is a modern experimental technique to measure velocity field over a plane in the flow field.

Pathlines

- A pathline is a Lagrangian concept in that we simply follow the path of an individual fluid particle as it moves around in the flow field.
- Thus, a pathline is the same as the fluid particle's material position vector $(x_{\text{particle}}(t), y_{\text{particle}}(t), z_{\text{particle}}(t))$ traced out over some finite time interval.

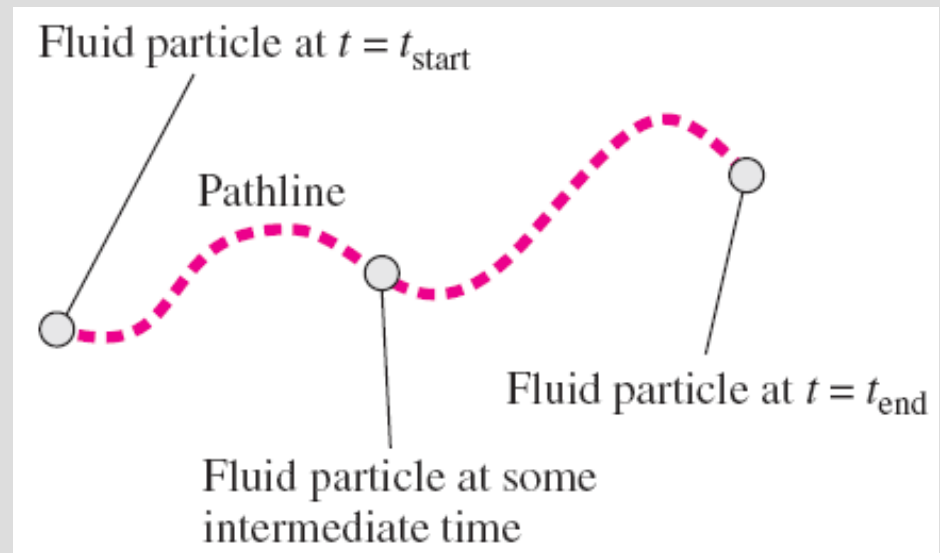

A *pathline* is formed by following the actual path of a fluid particle.

Pathlines produced by white tracer particles suspended in water and captured by time-exposure photography; as waves pass horizontally, each particle moves in an elliptical path during one wave period.

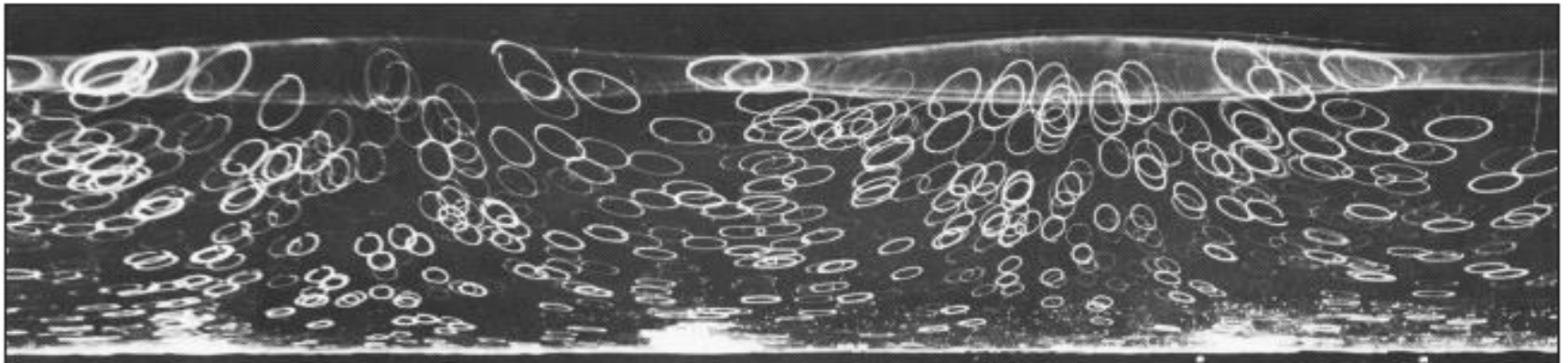

Streaklines

Streakline: The locus of fluid particles that have passed sequentially through a prescribed point in the flow.

Streaklines are the most common flow pattern generated in a physical experiment.

If you insert a small tube into a flow and introduce a continuous stream of tracer fluid (dye in a water flow or smoke in an air flow), the observed pattern is a streakline.

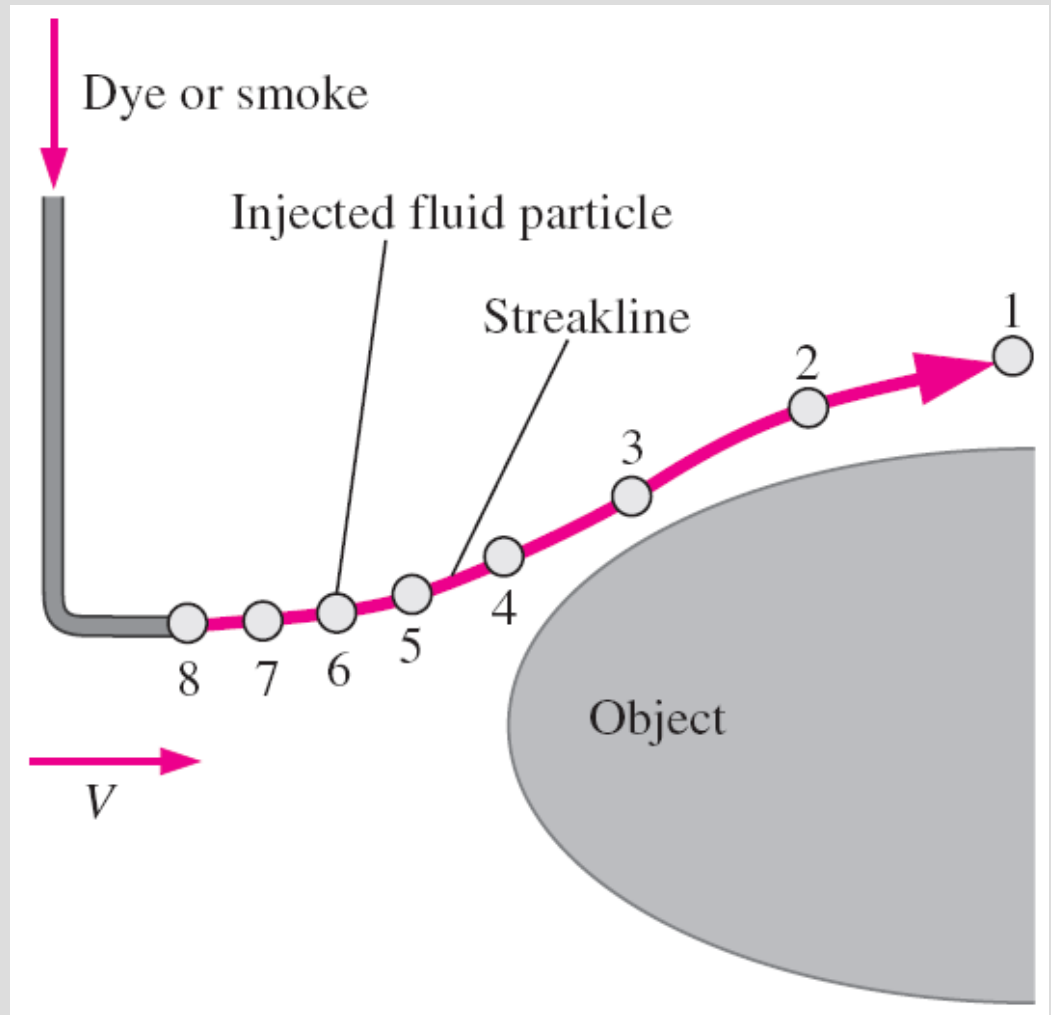

A *streakline* is formed by continuous introduction of dye or smoke from a point in the flow. Labeled tracer particles (1 through 8) were introduced sequentially.

Streaklines

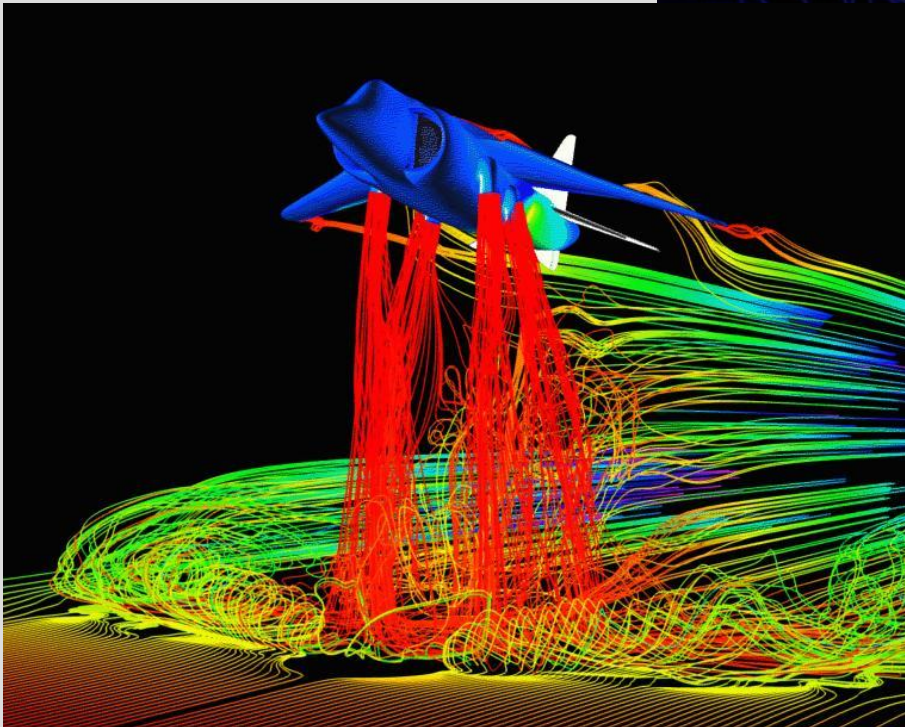
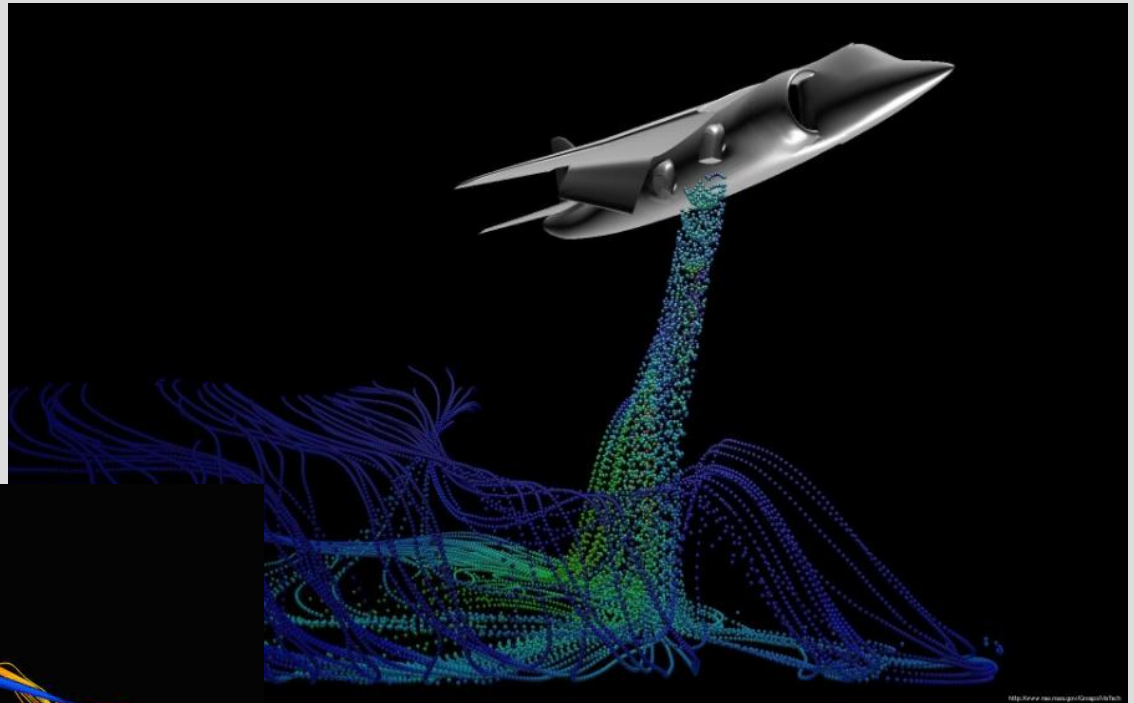

Timelines

Timeline: A set of adjacent fluid particles that were marked at the same (earlier) instant in time.

Timelines are particularly useful in situations where the uniformity of a flow (or lack thereof) is to be examined.

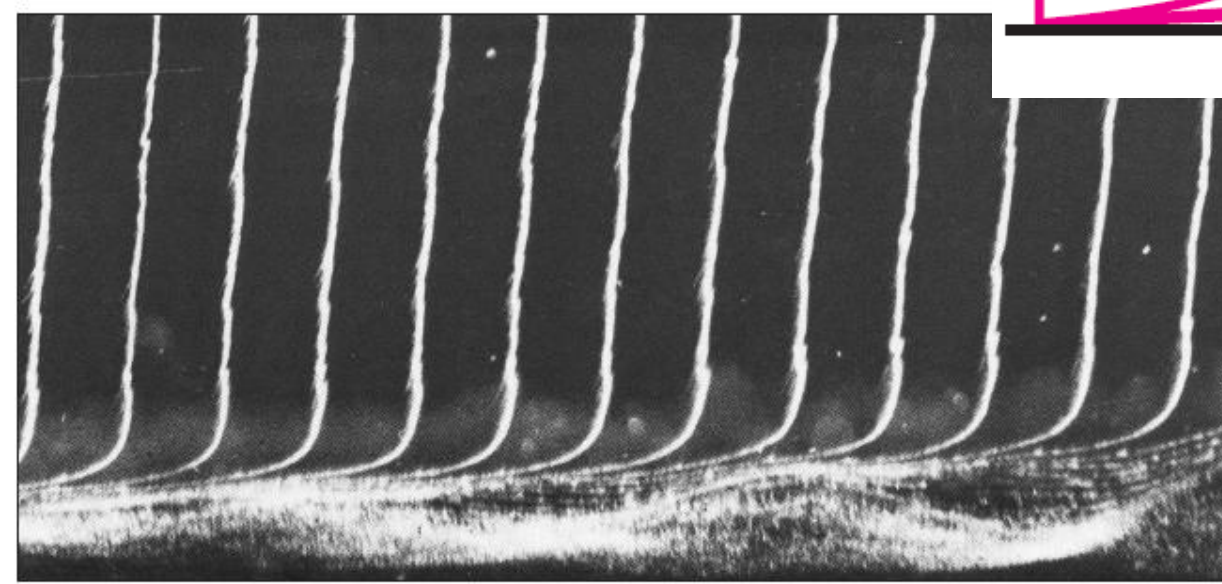
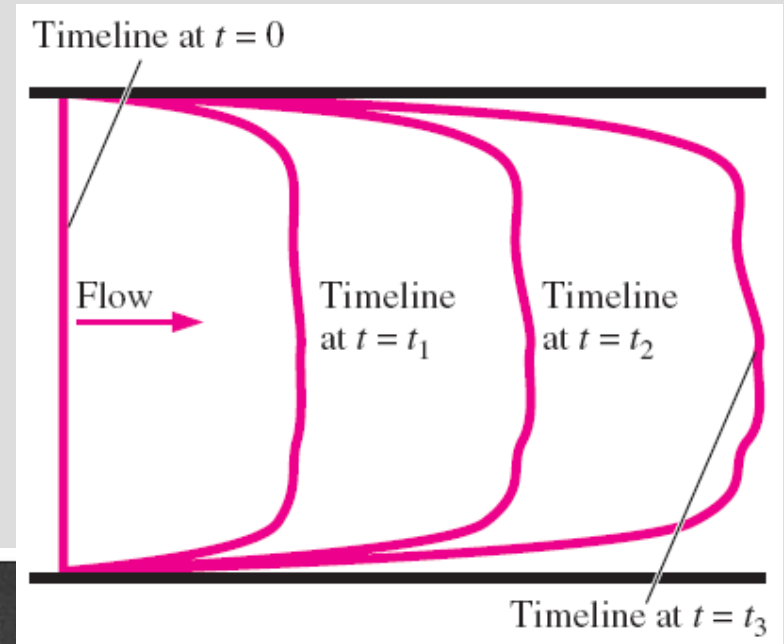

Timelines are formed by marking a line of fluid particles, and then watching that line move (and deform) through the flow field; timelines are shown at $t = 0$, t_1 , t_2 , and t_3 .

Timelines produced by a hydrogen bubble wire are used to visualize the boundary layer velocity profile shape. Flow is from left to right, and the hydrogen bubble wire is located to the left of the field of view. Bubbles near the wall reveal a flow instability that leads to turbulence.

Plots of Data

- A **Profile plot** indicates how the value of a scalar property varies along some desired direction in the flow field.
- A **Vector plot** is an array of arrows indicating the magnitude and direction of a vector property at an instant in time.
- A **Contour plot** shows curves of constant values of a scalar property for magnitude of a vector property at an instant in time.

Kinematic Description

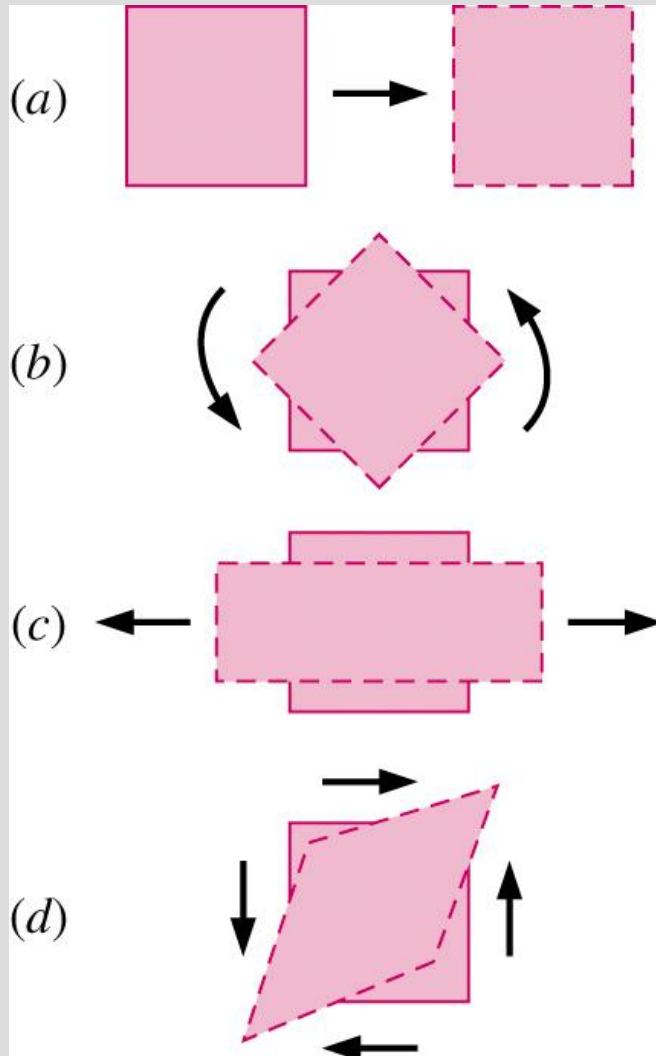

- In fluid mechanics, an element may undergo four fundamental types of motion.
 - a) Translation
 - b) Rotation
 - c) Linear strain
 - d) Shear strain
- Because fluids are in constant motion, motion and deformation is best described in terms of rates
 - a) velocity: rate of translation
 - b) angular velocity: rate of rotation
 - c) linear strain rate: rate of linear strain
 - d) shear strain rate: rate of shear strain

Rate of Translation and Rotation

- To be useful, these rates must be expressed in terms of velocity and derivatives of velocity
- The **rate of translation vector** is described as the velocity vector. In Cartesian coordinates:

$$\vec{V} = u\vec{i} + v\vec{j} + w\vec{k}$$

- Rate of rotation** at a point is defined as the average rotation rate of two initially perpendicular lines that intersect at that point. The rate of rotation vector in Cartesian coordinates:

$$\vec{\omega} = \frac{1}{2} \left(\frac{\partial w}{\partial y} - \frac{\partial v}{\partial z} \right) \vec{i} + \frac{1}{2} \left(\frac{\partial u}{\partial z} - \frac{\partial w}{\partial x} \right) \vec{j} + \frac{1}{2} \left(\frac{\partial v}{\partial x} - \frac{\partial u}{\partial y} \right) \vec{k}$$

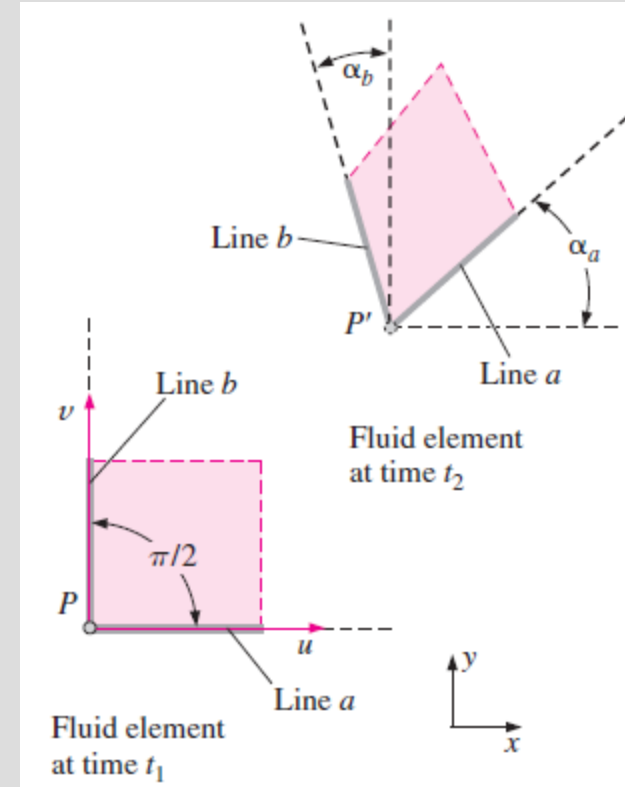

Linear Strain Rate

- **Linear Strain Rate** is defined as the rate of increase in length per unit length.
- In Cartesian coordinates

$$\varepsilon_{xx} = \frac{\partial u}{\partial x}, \varepsilon_{yy} = \frac{\partial v}{\partial y}, \varepsilon_{zz} = \frac{\partial w}{\partial z}$$

- Volumetric strain rate in Cartesian coordinates

$$\frac{1}{V} \frac{DV}{Dt} = \varepsilon_{xx} + \varepsilon_{yy} + \varepsilon_{zz} = \frac{\partial u}{\partial x} + \frac{\partial v}{\partial y} + \frac{\partial w}{\partial z}$$

- Since the volume of a fluid element is constant for an incompressible flow, the volumetric strain rate must be zero.

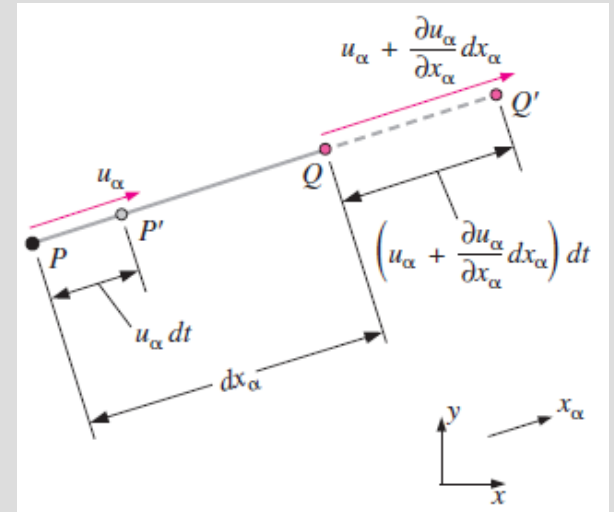

$$\varepsilon_{\alpha\alpha} = \frac{d}{dt} \left(\frac{P'Q' - PQ}{PQ} \right)$$

Shear Strain Rate

- **Shear Strain Rate** at a point is defined as *half of the rate of decrease of the angle between two initially perpendicular lines that intersect at a point.*
- Shear strain rate can be expressed in Cartesian coordinates as:

$$\varepsilon_{xy} = -\frac{1}{2} \frac{d}{dt} \alpha_{a-b} = \frac{1}{2} \left(\frac{\partial u}{\partial y} + \frac{\partial v}{\partial x} \right)$$

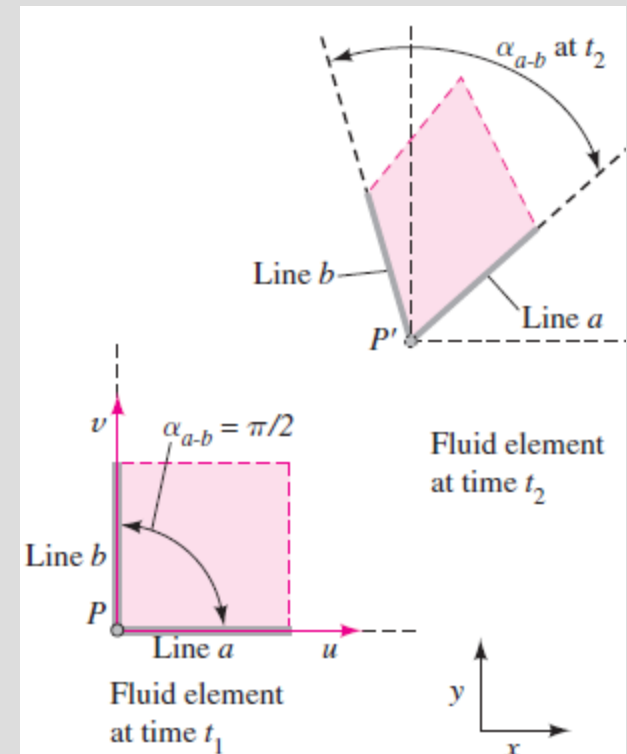

$$\varepsilon_{xy} = \frac{1}{2} \left(\frac{\partial u}{\partial y} + \frac{\partial v}{\partial x} \right), \varepsilon_{zx} = \frac{1}{2} \left(\frac{\partial w}{\partial x} + \frac{\partial u}{\partial z} \right), \varepsilon_{yz} = \frac{1}{2} \left(\frac{\partial v}{\partial z} + \frac{\partial w}{\partial y} \right)$$

Shear Strain Rate

We can combine linear strain rate and shear strain rate into one symmetric second-order tensor called the **strain-rate tensor**.

$$\boldsymbol{\varepsilon}_{ij} = \begin{pmatrix} \varepsilon_{xx} & \varepsilon_{xy} & \varepsilon_{xz} \\ \varepsilon_{yx} & \varepsilon_{yy} & \varepsilon_{yz} \\ \varepsilon_{zx} & \varepsilon_{zy} & \varepsilon_{zz} \end{pmatrix} = \begin{pmatrix} \frac{\partial u}{\partial x} & \frac{1}{2} \left(\frac{\partial u}{\partial y} + \frac{\partial v}{\partial x} \right) & \frac{1}{2} \left(\frac{\partial u}{\partial z} + \frac{\partial w}{\partial x} \right) \\ \frac{1}{2} \left(\frac{\partial v}{\partial x} + \frac{\partial u}{\partial y} \right) & \frac{\partial v}{\partial y} & \frac{1}{2} \left(\frac{\partial v}{\partial z} + \frac{\partial w}{\partial y} \right) \\ \frac{1}{2} \left(\frac{\partial w}{\partial x} + \frac{\partial u}{\partial z} \right) & \frac{1}{2} \left(\frac{\partial w}{\partial y} + \frac{\partial v}{\partial z} \right) & \frac{\partial w}{\partial z} \end{pmatrix}$$

Shear Strain Rate

- Purpose of our discussion of fluid element kinematics:
 - ✓ Better appreciation of the inherent complexity of fluid dynamics
 - ✓ Mathematical sophistication required to fully describe fluid motion
- Strain-rate tensor is important for numerous reasons. For example,
 - ✓ Develop relationships between fluid stress and strain rate.
 - ✓ Feature extraction and flow visualization in CFD simulations.

Shear Strain Rate

Example: Visualization of trailing-edge turbulent eddies for a hydrofoil with a beveled trailing edge

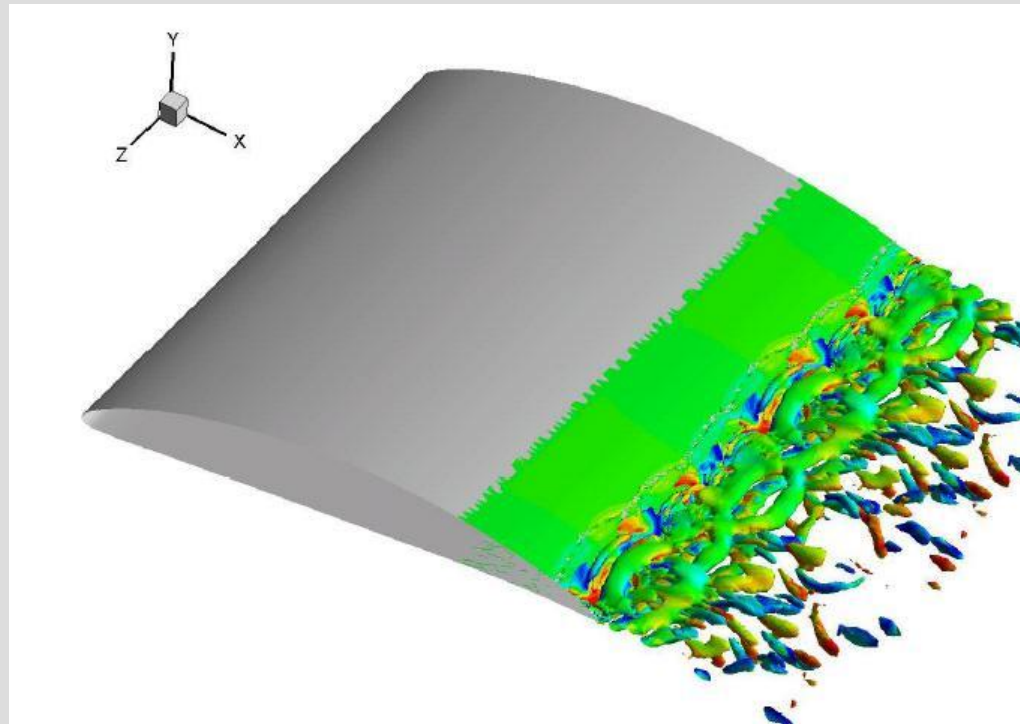

Feature extraction method is based upon eigen-analysis of the strain-rate tensor.

Vorticity and Rotationality

- The **vorticity vector** is defined as the curl of the velocity vector

$$\vec{\zeta} = \vec{\nabla} \times \vec{V}$$

- Vorticity is equal to twice the angular velocity of a fluid particle.
Cartesian coordinates

$$\vec{\zeta} = 2\vec{\omega}$$

Then

$$\vec{\zeta} = \left(\frac{\partial w}{\partial y} - \frac{\partial v}{\partial z} \right) \vec{i} + \left(\frac{\partial u}{\partial z} - \frac{\partial w}{\partial x} \right) \vec{j} + \left(\frac{\partial v}{\partial x} - \frac{\partial u}{\partial y} \right) \vec{k}$$

- In regions where $\zeta = 0$, the flow is called **irrotational**.
- Elsewhere, the flow is called **rotational**. (cylindrical coordinate)

$$\vec{\zeta} = \left(\frac{1}{r} \frac{\partial u_z}{\partial \theta} - \frac{\partial u_\theta}{\partial z} \right) \vec{e}_r + \left(\frac{\partial u_r}{\partial z} - \frac{\partial u_z}{\partial r} \right) \vec{e}_\theta + \left(\frac{\partial (ru_\theta)}{\partial r} - \frac{\partial u_r}{\partial \theta} \right) \vec{e}_z$$

Problem:

Consider fully developed **Couette flow** that shown in the figure. The flow is steady, incompressible and two-dimensional in the xy plane:

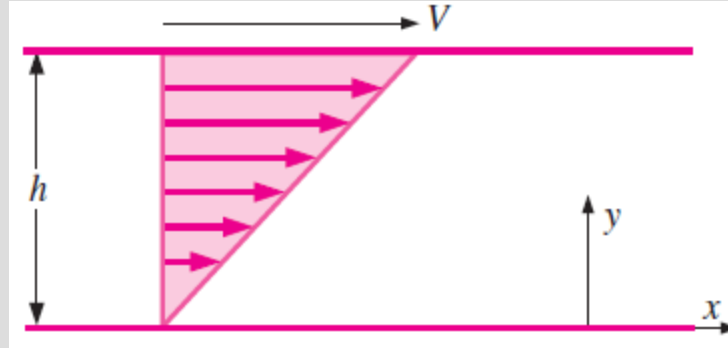

- Write the expression for the velocity field.
- Is this flow rotational or irrotational? Explain.
- If it is rotational, calculate the rotational component in the z direction.
- Do fluid particles in this flow rotate clockwise or counterclockwise?

Problem:

Consider the following steady, three-dimensional velocity field:

$$\vec{V} = (u, v, w) = (3 + 2x - y)\vec{i} + (2x - 2y)\vec{j} + (0.5xy)\vec{k}$$

Calculate the vorticity vector as a function of space (x, y, z) .

Reynolds—Transport Theorem (RTT)

- A **system** is a quantity of matter of fixed identity. *No mass can cross a system boundary.*
- A **control volume** is a region in space chosen for study. Mass can cross a control surface.
- The fundamental conservation laws (conservation of mass, energy, and momentum) apply directly to systems.
- However, in most fluid mechanics problems, control volume analysis is preferred over system analysis (for the same reason that the Eulerian description is usually preferred over the Lagrangian description).
- Therefore, we need to transform the conservation laws from a system to a control volume. This is accomplished with the Reynolds transport theorem (RTT).

THE REYNOLDS TRANSPORT THEOREM

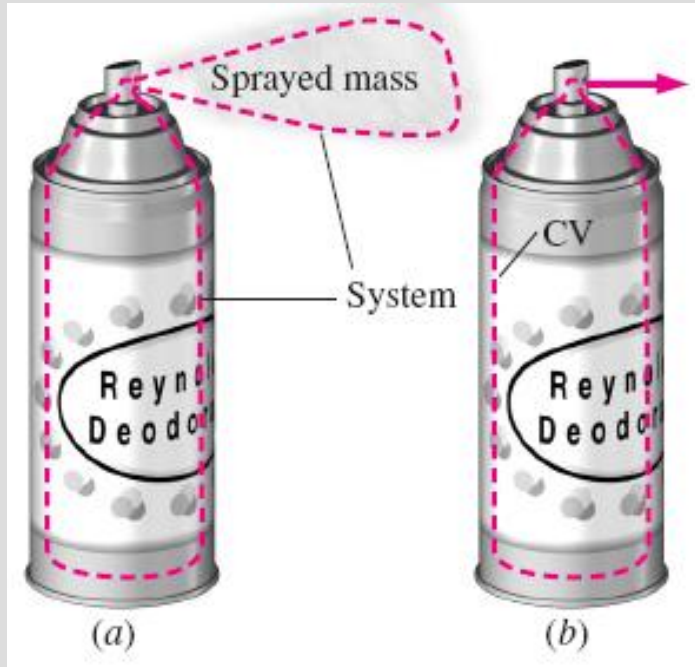

Two methods of analyzing the spraying of deodorant from a spray can:

(a) We follow the fluid as it moves and deforms. This is the *system approach*—no mass crosses the boundary, and the total mass of the system remains fixed.

(b) We consider a fixed interior volume of the can. This is the *control volume approach*—mass crosses the boundary.

The relationship between the time rates of change of an extensive property for a system and for a control volume is expressed by the *Reynolds transport theorem (RTT)*.

The *Reynolds transport theorem (RTT)* provides a link between the system approach and the control volume approach.

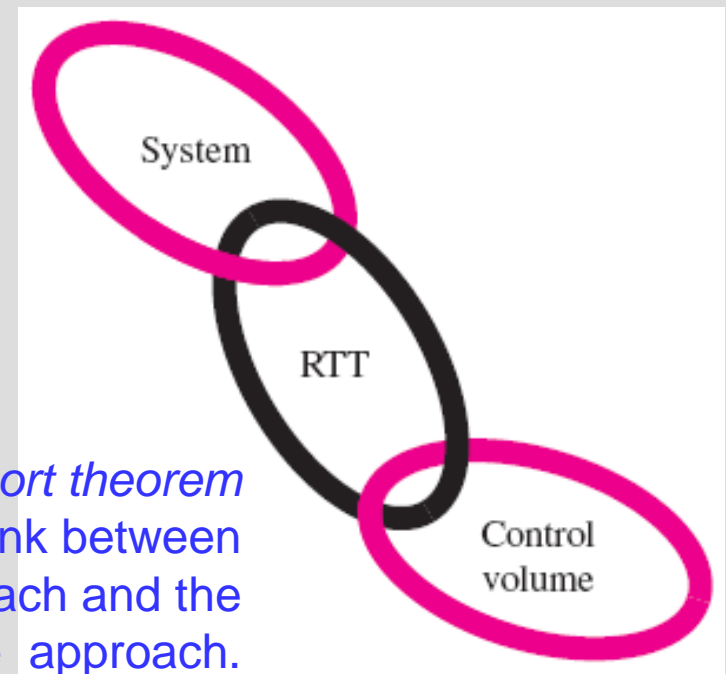

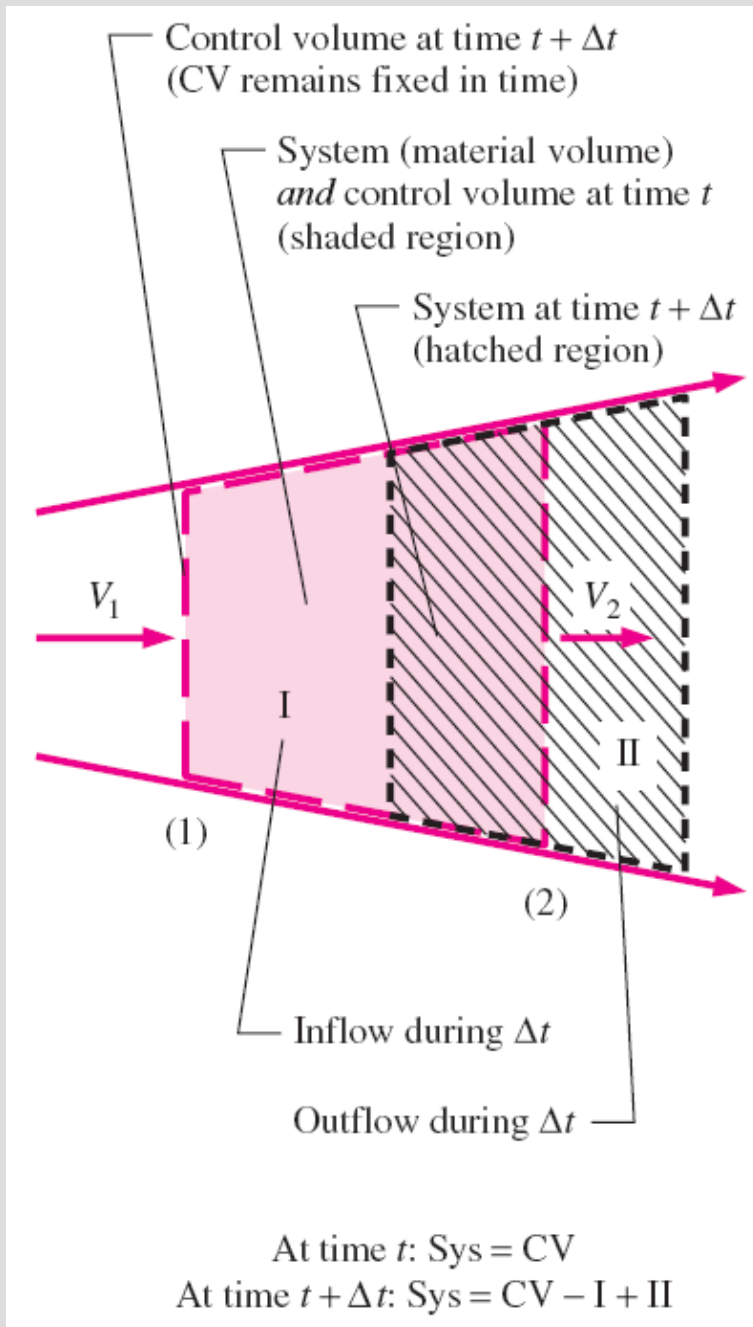

$$\frac{dB_{\text{sys}}}{dt} = \frac{dB_{\text{CV}}}{dt} - \dot{B}_{\text{in}} + \dot{B}_{\text{out}}$$

The time rate of change of the property B of the system is equal to the time rate of change of B of the control volume plus the net flux of B out of the control volume by mass crossing the control surface.

This equation applies at any instant in time, where it is assumed that the system and the control volume occupy the same space at that particular instant in time.

A moving *system* (hatched region) and a fixed *control volume* (shaded region) in a diverging portion of a flow field at times t and $t + \Delta t$. The upper and lower bounds are streamlines of the flow.

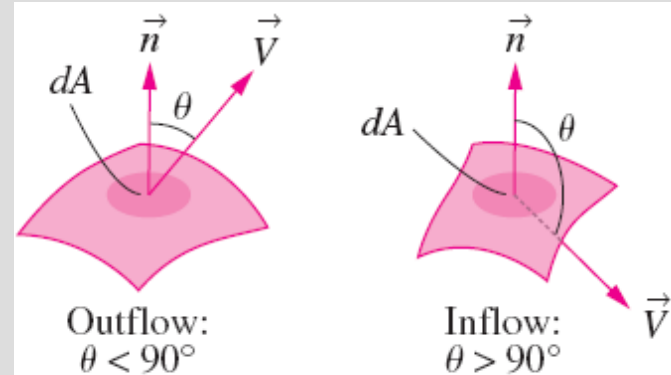
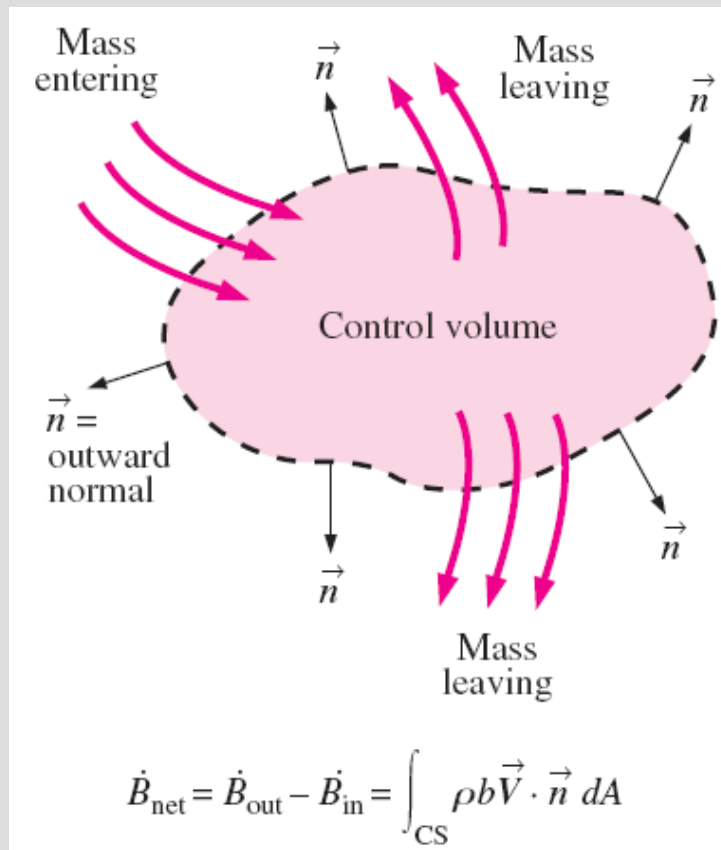

$$\vec{V} \cdot \vec{n} = |\vec{V}| |\vec{n}| \cos \theta = V \cos \theta$$

If $\theta < 90^\circ$, then $\cos \theta > 0$ (outflow).
 If $\theta > 90^\circ$, then $\cos \theta < 0$ (inflow).
 If $\theta = 90^\circ$, then $\cos \theta = 0$ (no flow).

Outflow and inflow of mass across the differential area of a control surface.

RTT, fixed CV:

$$\frac{dB_{\text{sys}}}{dt} = \frac{d}{dt} \int_{\text{CV}} \rho b dV + \int_{\text{CS}} \rho b \vec{V} \cdot \vec{n} dA$$

Alternate RTT, fixed CV:

$$\frac{dB_{\text{sys}}}{dt} = \int_{\text{CV}} \frac{\partial}{\partial t} (\rho b) dV + \int_{\text{CS}} \rho b \vec{V} \cdot \vec{n} dA$$

The integral of $\rho b \vec{V} \cdot \vec{n} dA$ over the control surface gives the net amount of the property B flowing out of the control volume (into the control volume if it is negative) per unit time.

Reynolds—Transport Theorem (RTT)

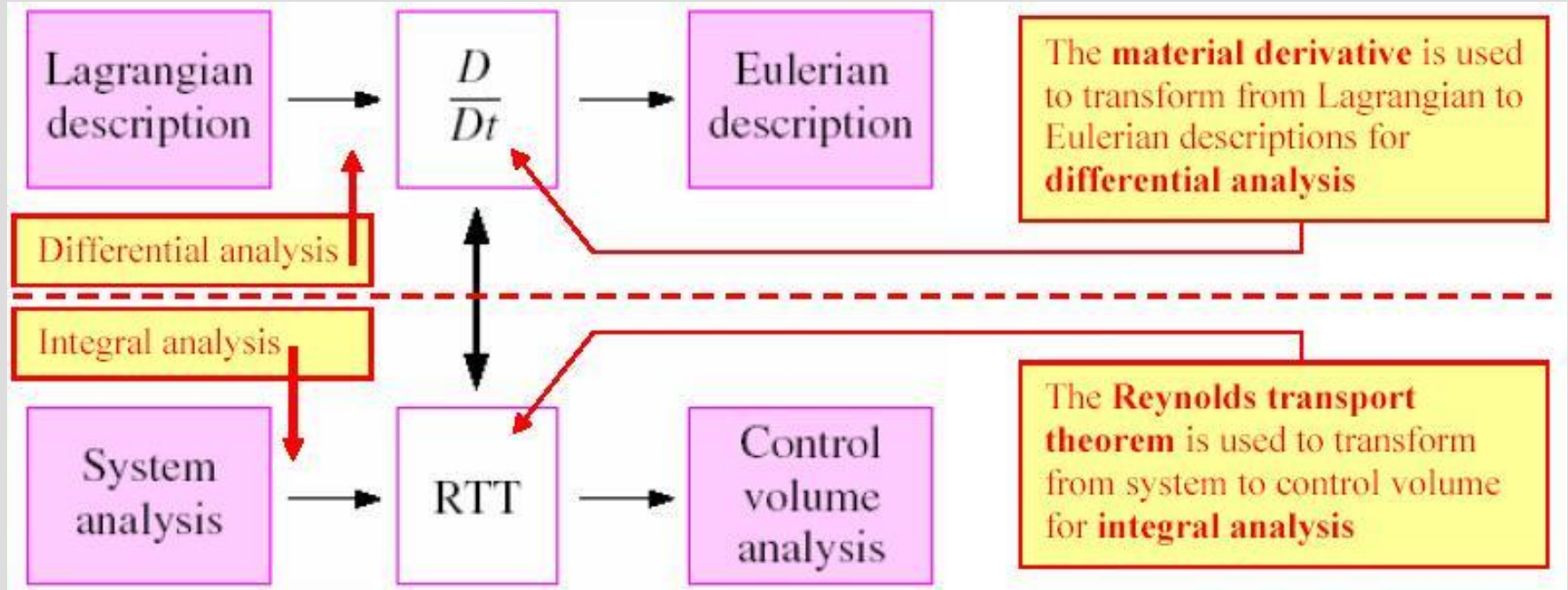

There is a direct analogy between the transformation from Lagrangian to Eulerian descriptions (for differential analysis using infinitesimally small fluid elements) and the transformation from systems to control volumes (for integral analysis using large, finite flow fields).

Reynolds—Transport Theorem (RTT)

- Material derivative (differential analysis):

$$\frac{Db}{Dt} = \frac{\partial b}{\partial t} + (\vec{V} \cdot \nabla) b$$

- General RTT, nonfixed CV (integral analysis):

$$\frac{dB_{sys}}{dt} = \int_{CV} \frac{\partial}{\partial t} (\rho b) dV + \int_{CS} \rho b \vec{V} \cdot \vec{n} dA$$

	Mass	Momentum	Energy	Angular momentum
B, Extensive properties	m	$m\vec{V}$	E	\vec{H}
b, Intensive properties	1	\vec{V}	e	$(\vec{r} \times \vec{V})$

- In next class, we will apply RTT to conservation of mass, energy, linear momentum, and angular momentum.

Reynolds—Transport Theorem (RTT)

- Interpretation of the RTT:
 - ✓ Time rate of change of the property B of the system is equal to (Term 1) + (Term 2)
 - ✓ Term 1: the time rate of change of B of the control volume
 - ✓ Term 2: the net flux of B out of the control volume by mass crossing the control surface

$$\frac{dB_{sys}}{dt} = \int_{CV} \frac{\partial}{\partial t} (\rho b) dV + \int_{CS} \rho b \vec{V} \cdot \vec{n} dA$$

RTT Special Cases

For **moving** and/or **deforming** control volumes,

$$\frac{dB_{sys}}{dt} = \int_{CV} \frac{\partial}{\partial t} (\rho b) dV + \int_{CS} \rho b \vec{V}_r \cdot \vec{n} dA$$

- Where the absolute velocity V in the second term is replaced by the **relative velocity**
 $V_r = V - V_{CS}$
- V_r is the fluid velocity expressed relative to a coordinate system moving **with** the control volume.

RTT Special Cases

For steady flow, the time derivative drops out,

$$\frac{dB_{sys}}{dt} = \int_{CV} \frac{\partial}{\partial t} (\rho b) dV + \int_{CS} \rho b \vec{V}_r \cdot \vec{n} dA = \int_{CS} \rho b \vec{V}_r \cdot \vec{n} dA$$

For control volumes with well-defined inlets and outlets

$$\frac{dB_{sys}}{dt} = \frac{d}{dt} \int_{CV} \rho b dV + \sum_{out} \rho_{avg} b_{avg} V_{r,avg} A - \sum_{in} \rho_{avg} b_{avg} V_{r,avg} A$$

$$\int_A \rho b \vec{V}_r \cdot \vec{n} dA \cong b_{\text{avg}} \int_A \rho \vec{V}_r \cdot \vec{n} dA = b_{\text{avg}} \dot{m}_r$$

$$\frac{dB_{\text{sys}}}{dt} = \frac{d}{dt} \int_{\text{CV}} \rho b dV + \underbrace{\sum_{\text{out}} \dot{m}_r b_{\text{avg}}}_{\text{for each outlet}} - \underbrace{\sum_{\text{in}} \dot{m}_r b_{\text{avg}}}_{\text{for each inlet}}$$

Approximate RTT for well-defined inlets and outlets:

$$\dot{m}_r \approx \rho_{\text{avg}} \dot{V}_r = \rho_{\text{avg}} V_{r, \text{avg}} A$$

$$\frac{dB_{\text{sys}}}{dt} = \frac{d}{dt} \int_{\text{CV}} \rho b dV + \underbrace{\sum_{\text{out}} \rho_{\text{avg}} b_{\text{avg}} V_{r, \text{avg}} A}_{\text{for each outlet}} - \underbrace{\sum_{\text{in}} \rho_{\text{avg}} b_{\text{avg}} V_{r, \text{avg}} A}_{\text{for each inlet}}$$

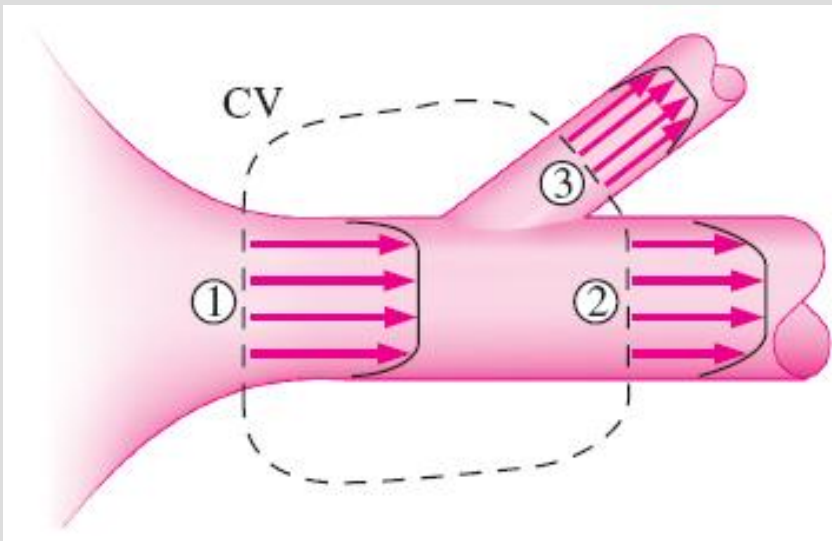

An example control volume in which there is one well-defined inlet (1) and two well-defined outlets (2 and 3). In such cases, the control surface integral in the RTT can be more conveniently written in terms of the average values of fluid properties crossing each inlet and outlet.

Quiz:

The profile of velocity in the tube with 2cm of diameter that shown in the figure is given by:

$$u(r,t) = 2 \left(1 - \frac{r^2}{r_0^2} \right) (1 - e^{-t/10}) \text{ m/s}$$

Where r_0 is the external radius of the tube and t is given in seconds. Calculate the maxima velocity and the maxima acceleration at:

- Along of central line of the tube
- Along of stream line at $r = 0,5$ cm

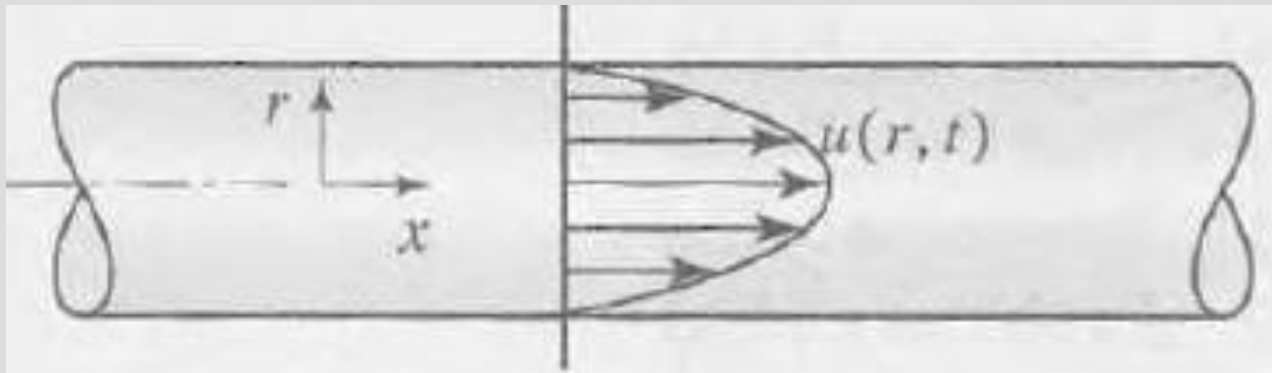

Principle of Mass conservation

Conservation of Mass

- **Conservation of mass principle** is one of the most fundamental principles in nature.
- Mass, like energy, is a conserved property, and it cannot be created or destroyed during a process.
- For ***closed systems*** mass conservation is implicit since the mass of the system remains constant during a process.
- For ***control volumes***, mass can cross the boundaries which means that we must keep track of the amount of mass entering and leaving the control volume.

Mass and Volume Flow Rates

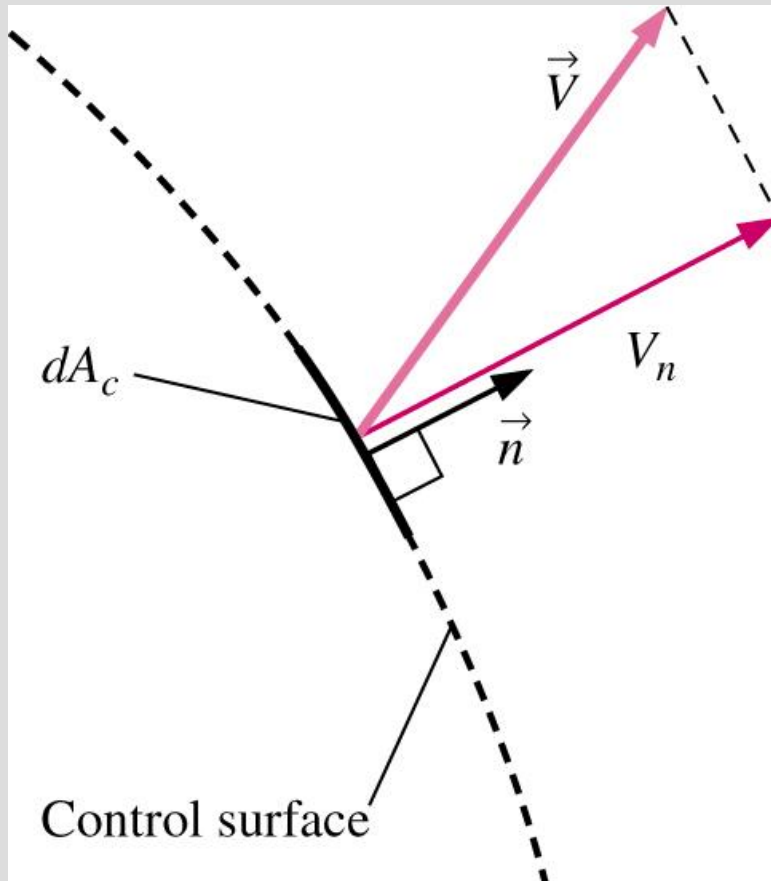

- The amount of mass flowing through a control surface per unit time is called the **mass flow rate** and is denoted \dot{m}
- The dot over a symbol is used to indicate *time rate of change*.
- Flow rate across the entire cross-sectional area of a pipe or duct is obtained by integration

$$\dot{m} = \int_{A_c} \delta m = \int_{A_c} \rho V_n dA_c$$

- While this expression for \dot{m} is exact, it is not always convenient for engineering analyses.

Average Velocity and Volume Flow Rate

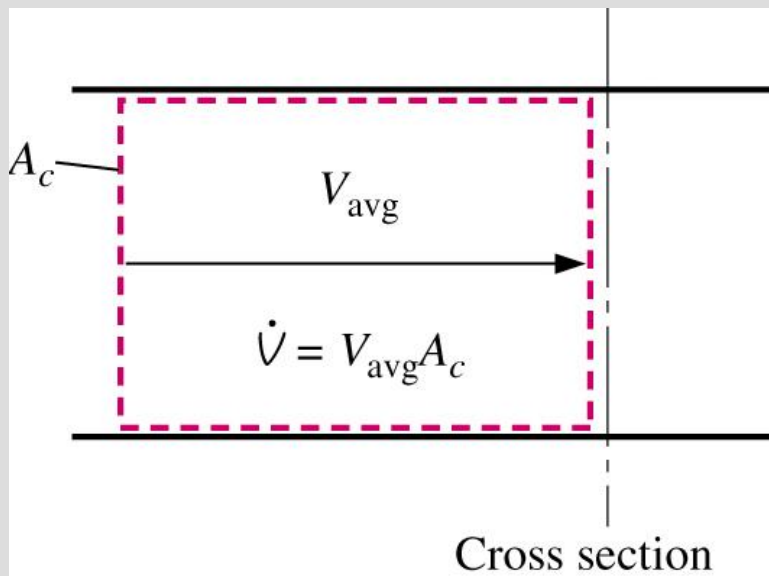
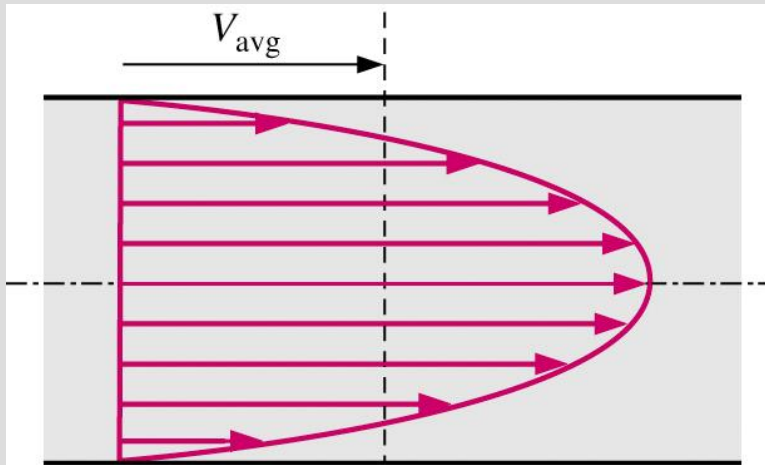

- Integral in \dot{m} can be replaced with average values of ρ and V_n

$$V_{avg} = \frac{1}{A_c} \int_{A_c} V_n dA_c$$

- For many flows variation of ρ is very small: $\dot{m} = \rho V_{avg} A_c$

- Volume flow rate \dot{V} is given by

$$\dot{V} = \int_{A_c} V_n dA_c = V_{avg} A_c = V A_c$$

- Note: many textbooks use Q instead of \dot{V} for volume flow rate.
- Mass and volume flow rates are related by $\dot{m} = \rho \dot{V}$

Conservation of Mass Principle

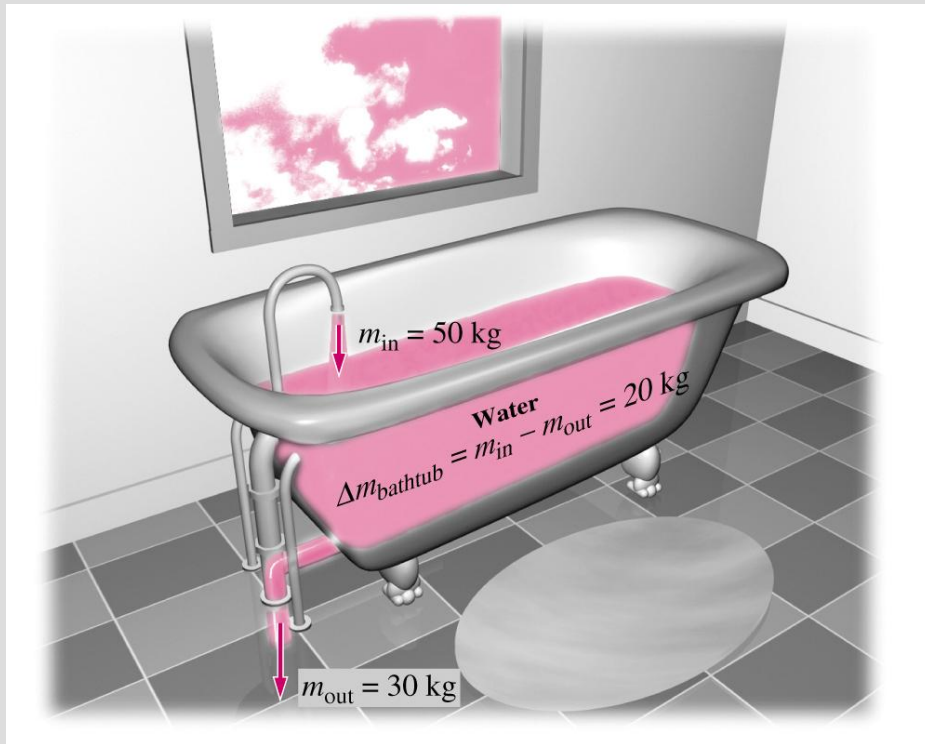

- The **conservation of mass principle** can be expressed as

$$\dot{m}_{in} - \dot{m}_{out} = \frac{dm_{CV}}{dt}$$

- Where \dot{m}_{in} and \dot{m}_{out} are the total rates of mass flow into and out of the CV, and dm_{CV}/dt is the rate of change of mass within the CV.

Conservation of Mass Principle

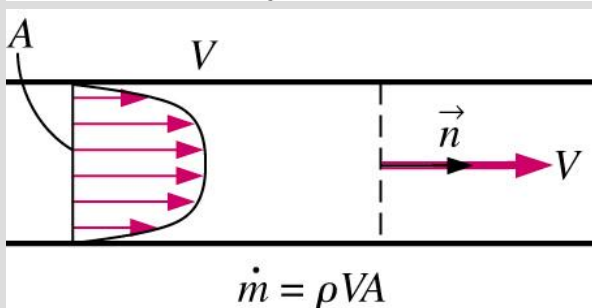
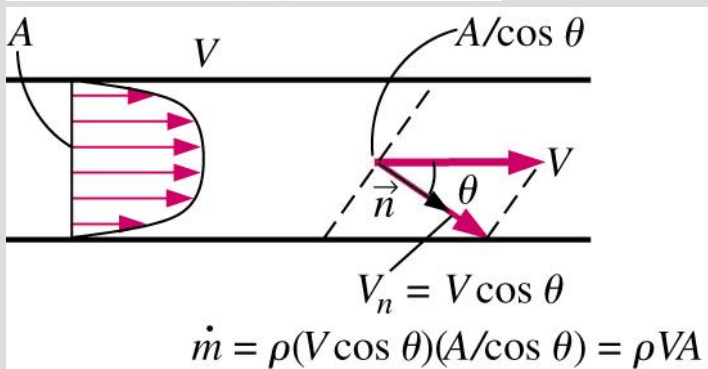
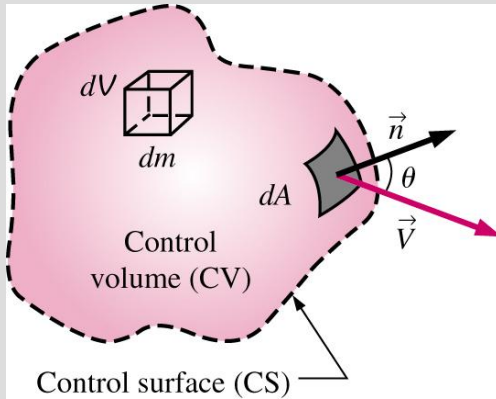

- For CV of arbitrary shape,
 - ✓ rate of change of mass within the CV

$$\frac{dm_{CV}}{dt} = \frac{d}{dt} \int_{CV} \rho dV$$

- ✓ net mass flow rate

$$\dot{m}_{net} = \int_{CS} \delta \dot{m} = \int_{CS} \rho V_n dA = \int_{CS} \rho (\vec{V} \cdot \vec{n}) dA$$

- Therefore, general conservation of mass for a fixed CV is:

$$\frac{d}{dt} \int_{CV} \rho dV + \int_{CS} \rho (\vec{V} \cdot \vec{n}) dA = 0$$

Mass Balance for Steady-Flow Processes

During a steady-flow process, the total amount of mass contained within a control volume does not change with time ($m_{CV} = \text{constant}$).

Then the conservation of mass principle requires that **the total amount of mass entering a control volume equal the total amount of mass leaving it.**

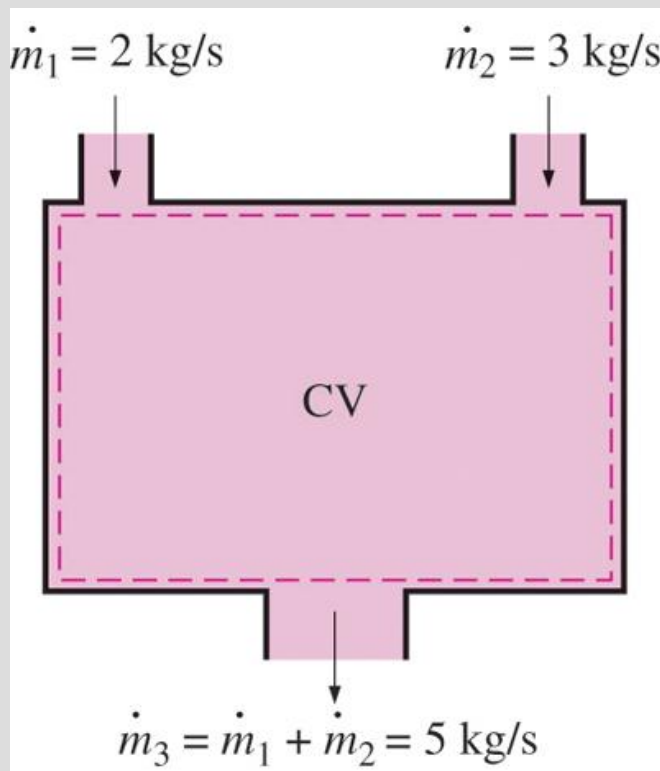

For steady-flow processes, we are interested in the amount of mass flowing per unit time, that is, *the mass flow rate*.

$$\sum_{\text{in}} \dot{m} = \sum_{\text{out}} \dot{m} \quad (\text{kg/s}) \quad \text{Multiple inlets and exits}$$

$$\dot{m}_1 = \dot{m}_2 \quad \rightarrow \quad \rho_1 V_1 A_1 = \rho_2 V_2 A_2 \quad \text{Single stream}$$

Many engineering devices such as nozzles, diffusers, turbines, compressors, and pumps involve a single stream (only one inlet and one outlet).

Conservation of mass principle for a two-inlet–one-outlet steady-flow system.

Special Case: Incompressible Flow

The conservation of mass relations can be simplified even further when the fluid is incompressible, which is usually the case for liquids.

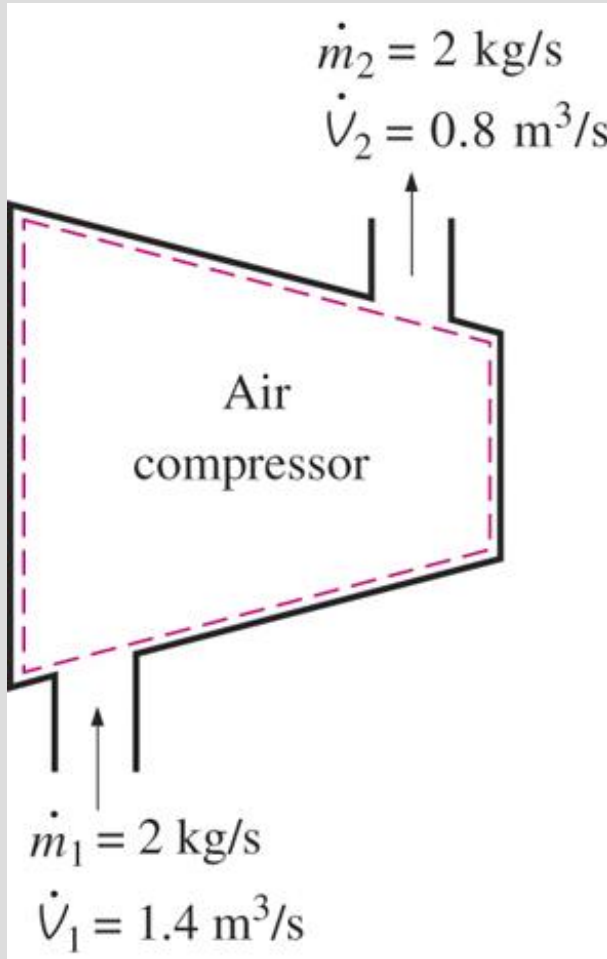

$$\sum_{\text{in}} \dot{V} = \sum_{\text{out}} \dot{V} \quad (\text{m}^3/\text{s})$$

Steady,
incompressible

$$\dot{V}_1 = \dot{V}_2 \rightarrow V_1 A_1 = V_2 A_2$$

Steady,
incompressible
flow (single stream)

There is no such thing as a “**conservation of volume**” principle.

However, for steady flow of liquids, the volume flow rates, as well as the mass flow rates, remain constant since liquids are essentially incompressible substances.

During a steady-flow process, volume flow rates are not necessarily conserved although mass flow rates are.

Problem:

Se infla un globo con un suministro de agua de $0.6 \text{ m}^3/\text{s}$ (Fig. E4.4). Calcule la velocidad de crecimiento del radio en el momento en que $R = 0.5 \text{ m}$.

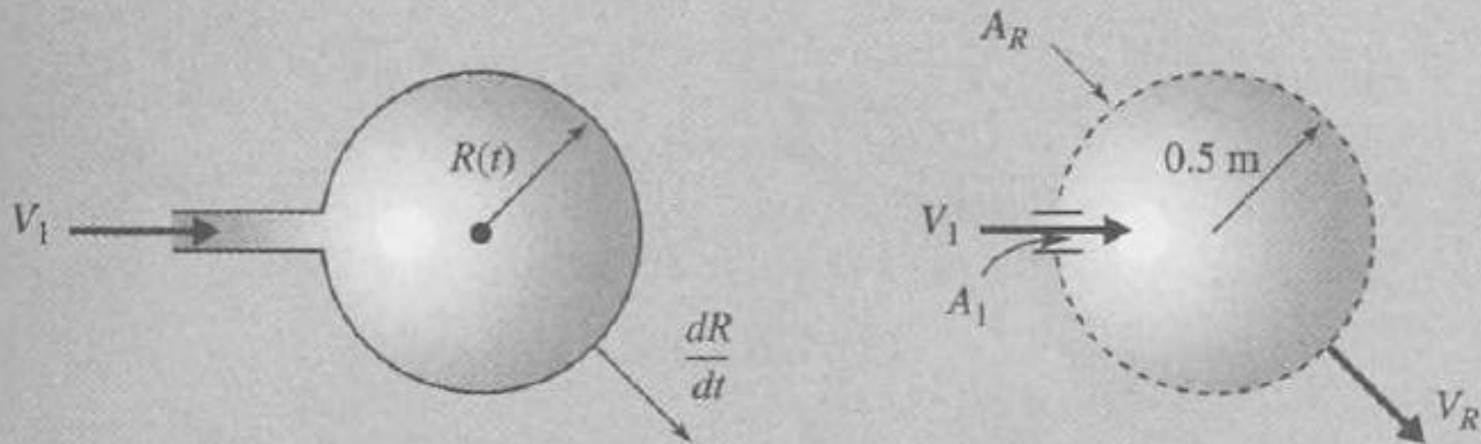

Problem:

With the data shown in the figure, calculate the velocity of height level change in the tank.

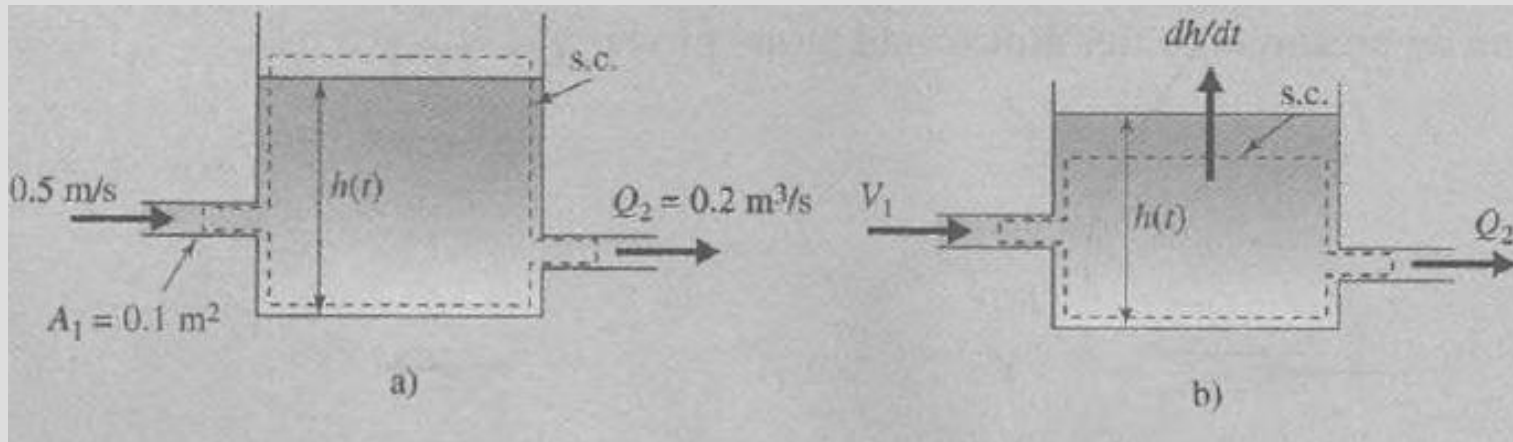

Problem:

Por un tubo de 4 pulg de diámetro fluye aire a 60°F y 40 psia con un flujo de masa de 0.2 slug/seg. El tubo se transforma en un ducto rectangular de 2×3 pulg en el cual $T = 150^{\circ}\text{F}$ y $p = 7$ psia. Calcule la velocidad en cada sección.

PRINCIPLE OF ENERGY CONSERVATION

INTRODUCTION

- If we take the entire room—including the air and the refrigerator (or fan)—as the system, which is an adiabatic closed system since the room is well-sealed and well-insulated, the only energy interaction involved is the electrical energy crossing the system boundary and entering the room.
- As a result of the conversion of electric energy consumed by the device to heat, **the room temperature will rise.**



A fan running in a well-sealed and well-insulated room will raise the temperature of air in the room.

A refrigerator operating with its door open in a well-sealed and well-insulated room

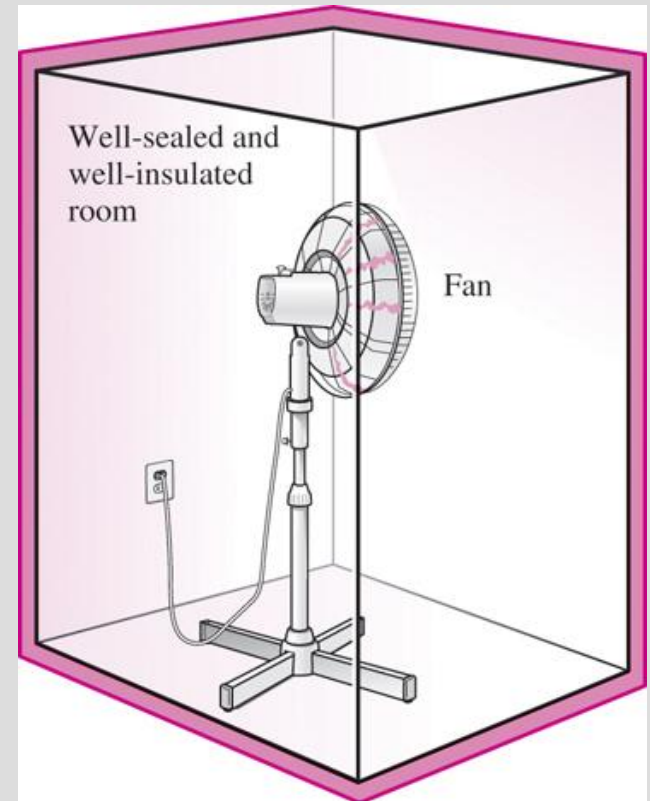

FORMS OF ENERGY

- Energy can exist in numerous forms such as thermal, mechanical, kinetic, potential, electric, magnetic, chemical, and nuclear, and their sum constitutes the **total energy, E** of a system.
- Thermodynamics deals only with the **change** of the total energy.
- **Macroscopic forms of energy:** Those a system possesses as a whole with respect to some outside reference frame, such as kinetic and potential energies.
- **Microscopic forms of energy:** Those related to the molecular structure of a system and the degree of the molecular activity.
- **Internal energy, U :** The sum of all the microscopic forms of energy.
- **Kinetic energy, KE:** The energy that a system possesses as a result of its motion relative to some reference frame.
- **Potential energy, PE:** The energy that a system possesses as a result of its elevation in a gravitational field.



The macroscopic energy of an object changes with velocity and elevation.

$$\text{KE} = m \frac{V^2}{2} \quad (\text{kJ}) \quad \text{Kinetic energy}$$

$$\text{ke} = \frac{V^2}{2} \quad (\text{kJ/kg}) \quad \text{Kinetic energy per unit mass}$$

$$\text{PE} = mgz \quad (\text{kJ}) \quad \text{Potential energy}$$

$$\text{pe} = gz \quad (\text{kJ/kg}) \quad \text{Potential energy per unit mass}$$

$$E = U + \text{KE} + \text{PE} = U + m \frac{V^2}{2} + mgz \quad (\text{kJ}) \quad \text{Total energy of a system}$$

$$e = u + \text{ke} + \text{pe} = u + \frac{V^2}{2} + gz \quad (\text{kJ/kg}) \quad \text{Energy of a system per unit mass}$$

$$e = \frac{E}{m} \quad (\text{kJ/kg}) \quad \text{Total energy per unit mass}$$

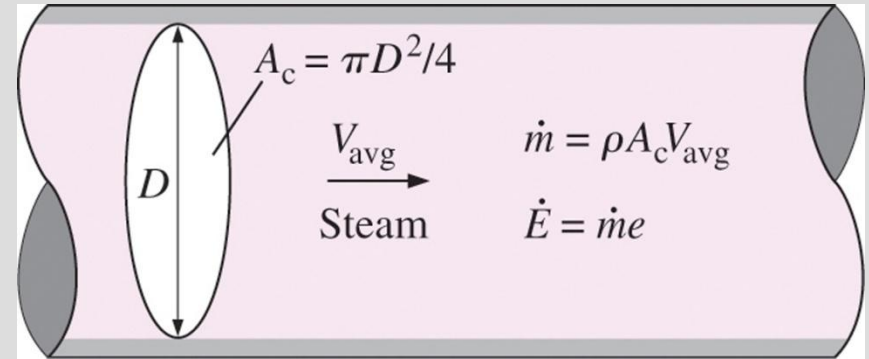

Mass flow rate

$$\dot{m} = \rho \dot{V} = \rho A_c V_{\text{avg}} \quad (\text{kg/s})$$

Energy flow rate

$$\dot{E} = \dot{m}e \quad (\text{kJ/s or kW})$$

Some Physical Insight to Internal Energy

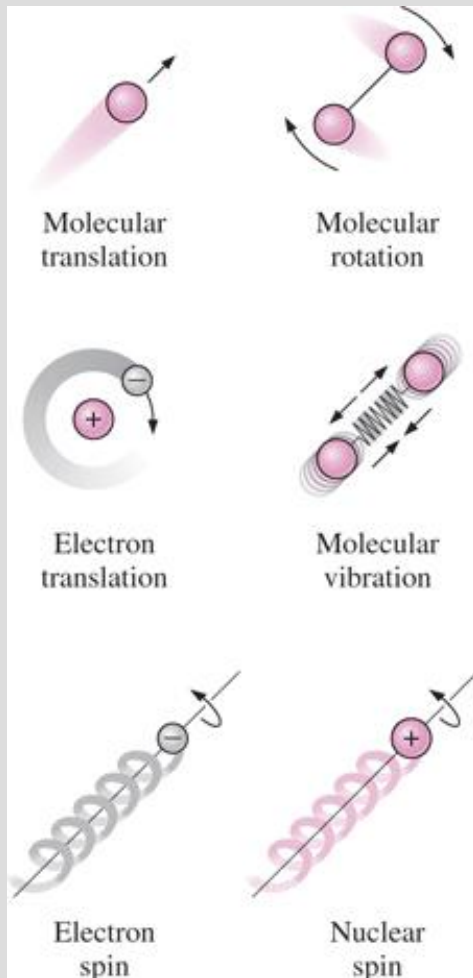

The various forms of microscopic energies that make up *sensible* energy.

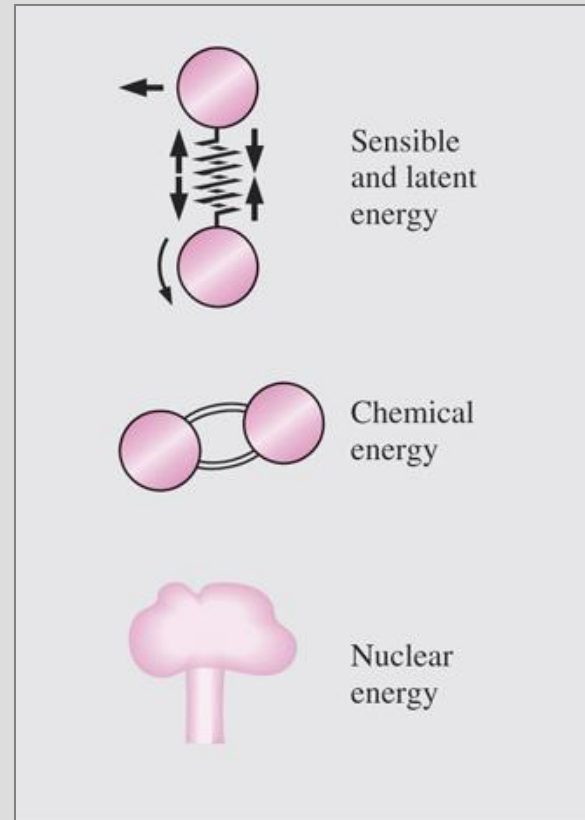

The internal energy of a system is the sum of all forms of the microscopic energies.

Sensible energy: The portion of the internal energy of a system associated with the kinetic energies of the molecules.

Latent energy: The internal energy associated with the phase of a system.

Chemical energy: The internal energy associated with the atomic bonds in a molecule.

Nuclear energy: The tremendous amount of energy associated with the strong bonds within the nucleus of the atom itself.

Thermal = Sensible + Latent

Internal = Sensible + Latent + Chemical + Nuclear

- The total energy of a system, can be *contained* or *stored* in a system, and thus can be viewed as the **static forms of energy**.
- The forms of energy not stored in a system can be viewed as the **dynamic forms of energy** or as **energy interactions**.
- The dynamic forms of energy are recognized at the system boundary as they cross it, and they represent the energy gained or lost by a system during a process.
- The only two forms of energy interactions associated with a closed system are **heat transfer** and **work**.
- **The difference between heat transfer and work:** An energy interaction is heat transfer if its driving force is a temperature difference. Otherwise it is work.

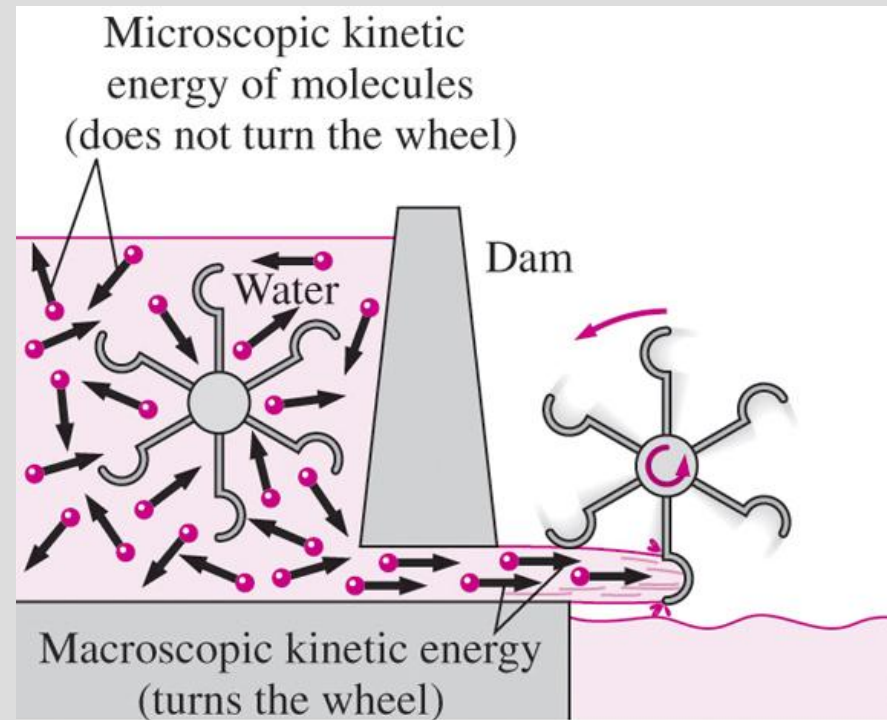

The *macroscopic* kinetic energy is an organized form of energy and is much more useful than the disorganized *microscopic* kinetic energies of the molecules.

More on Nuclear Energy

- The best known **fission** reaction involves the split of the uranium atom (the U-235 isotope) into other elements and is commonly used to generate electricity in nuclear power plants (440 of them in 2004, generating 363,000 MW worldwide), to power nuclear submarines and aircraft carriers, and even to power spacecraft as well as building nuclear bombs.
- Nuclear energy by **fusion** is released when two small nuclei combine into a larger one.
- The uncontrolled fusion reaction was achieved in the early 1950s, but all the efforts since then to achieve controlled fusion by massive lasers, powerful magnetic fields, and electric currents to generate power have failed.

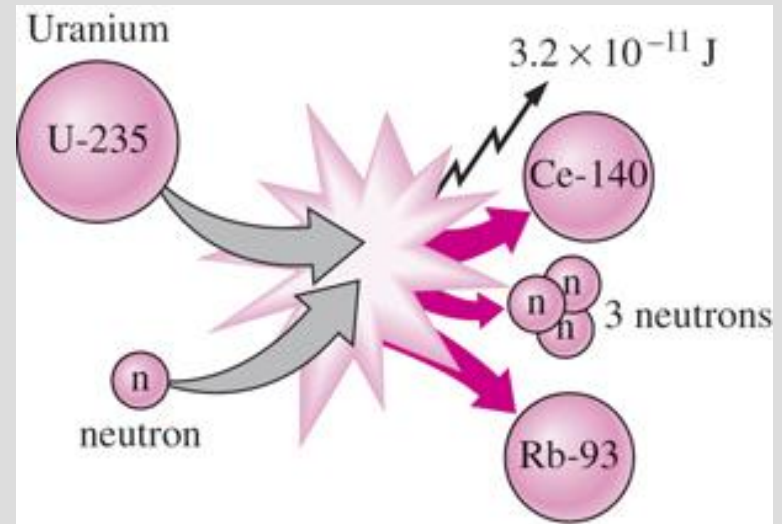

(a) Fission of uranium

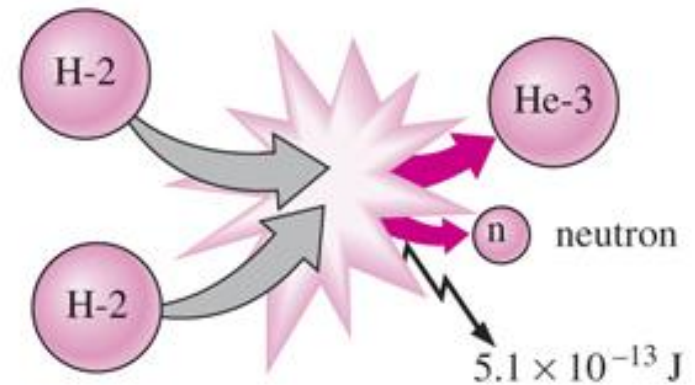

(b) Fusion of hydrogen

The fission of uranium and the fusion of hydrogen during nuclear reactions, and the release of nuclear energy.

Mechanical Energy

Mechanical energy: The form of energy that can be converted to mechanical work completely and directly by an ideal mechanical device such as an ideal turbine.

Kinetic and potential energies: The familiar forms of mechanical energy.

$$e_{\text{mech}} = \frac{P}{\rho} + \frac{V^2}{2} + gz$$

Mechanical energy of a flowing fluid per unit mass

$$\dot{E}_{\text{mech}} = \dot{m}e_{\text{mech}} = \dot{m} \left(\frac{P}{\rho} + \frac{V^2}{2} + gz \right)$$

Rate of mechanical energy of a flowing fluid

Mechanical energy change of a fluid during incompressible flow per unit mass

$$\Delta e_{\text{mech}} = \frac{P_2 - P_1}{\rho} + \frac{V_2^2 - V_1^2}{2} + g(z_2 - z_1) \quad (\text{kJ/kg})$$

Rate of mechanical energy change of a fluid during incompressible flow

$$\Delta \dot{E}_{\text{mech}} = \dot{m} \Delta e_{\text{mech}} = \dot{m} \left(\frac{P_2 - P_1}{\rho} + \frac{V_2^2 - V_1^2}{2} + g(z_2 - z_1) \right) \quad (\text{kW})$$

ENERGY TRANSFER BY HEAT

Heat: The form of energy that is transferred between two systems (or a system and its surroundings) by virtue of a temperature difference.

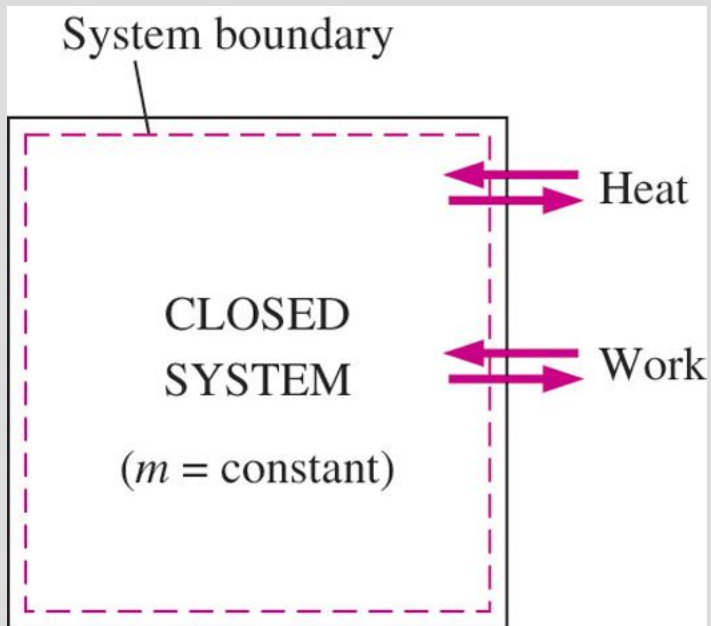

Energy can cross the boundaries of a closed system in the form of heat and work.

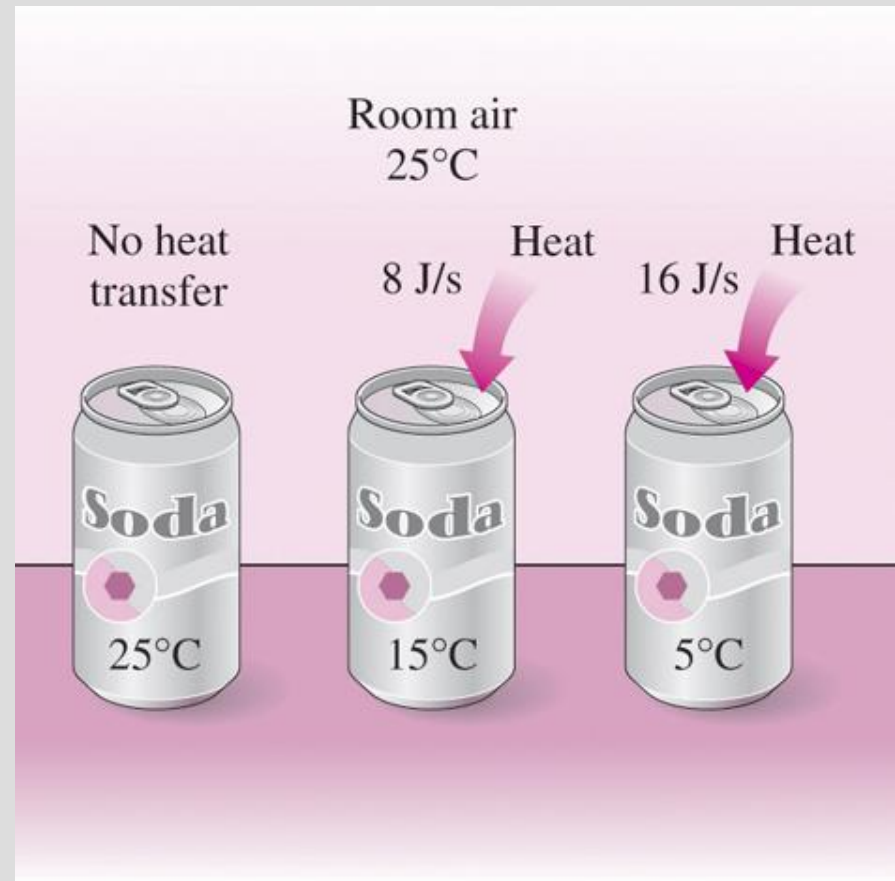

Temperature difference is the driving force for heat transfer. The larger the temperature difference, the higher is the rate of heat transfer.

$$q = \frac{Q}{m} \quad (\text{kJ/kg})$$

Heat transfer per unit mass

$$Q = \dot{Q} \Delta t \quad (\text{kJ})$$

Amount of heat transfer when heat transfer rate is constant

$$Q = \int_{t_1}^{t_2} \dot{Q} dt \quad (\text{kJ})$$

Amount of heat transfer when heat transfer rate changes with time

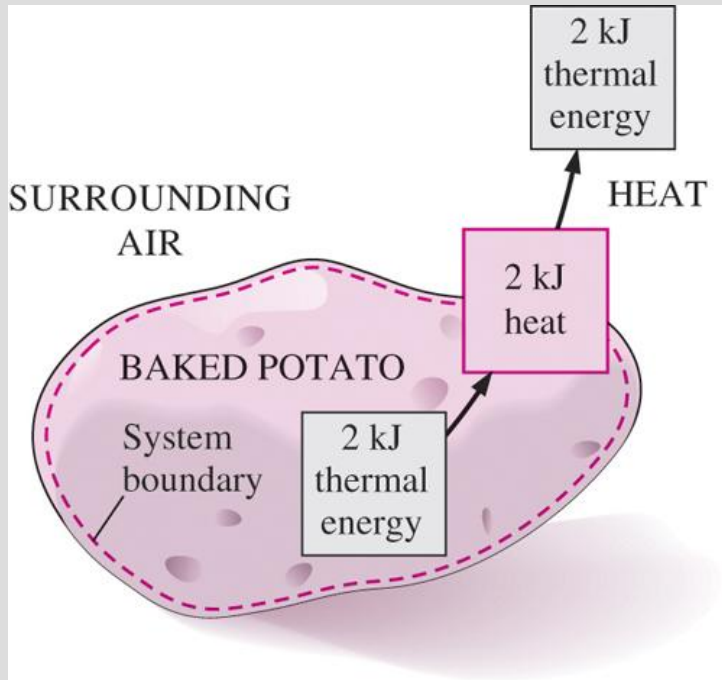
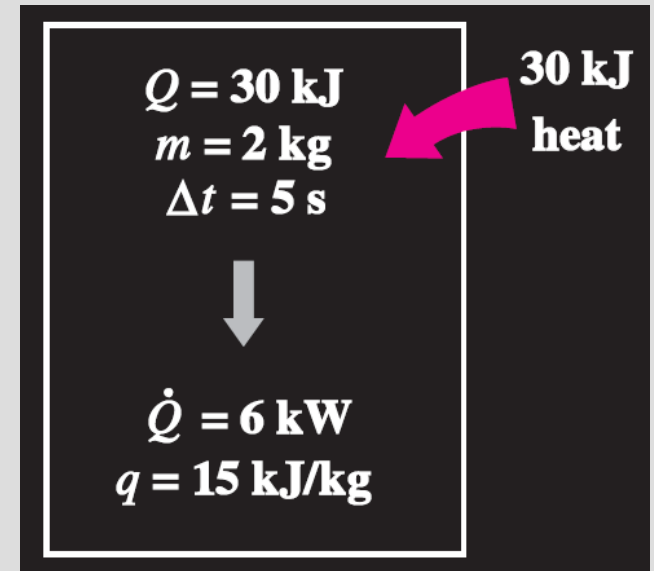

Energy is recognized as heat transfer only as it crosses the system boundary.

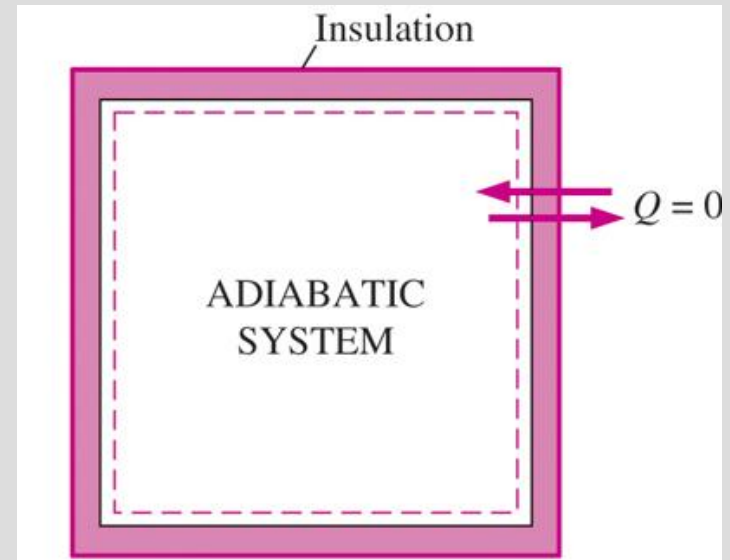

During an adiabatic process, a system exchanges no heat with its surroundings.

Historical Background on Heat

- **Kinetic theory:** Treats molecules as tiny balls that are in motion and thus possess kinetic energy.
- **Heat:** The energy associated with the random motion of atoms and molecules.

Heat transfer mechanisms:

- **Conduction:** The transfer of energy from the more energetic particles of a substance to the adjacent less energetic ones as a result of interaction between particles.
- **Convection:** The transfer of energy between a solid surface and the adjacent fluid that is in motion, and it involves the combined effects of conduction and fluid motion.
- **Radiation:** The transfer of energy due to the emission of electromagnetic waves (or photons).

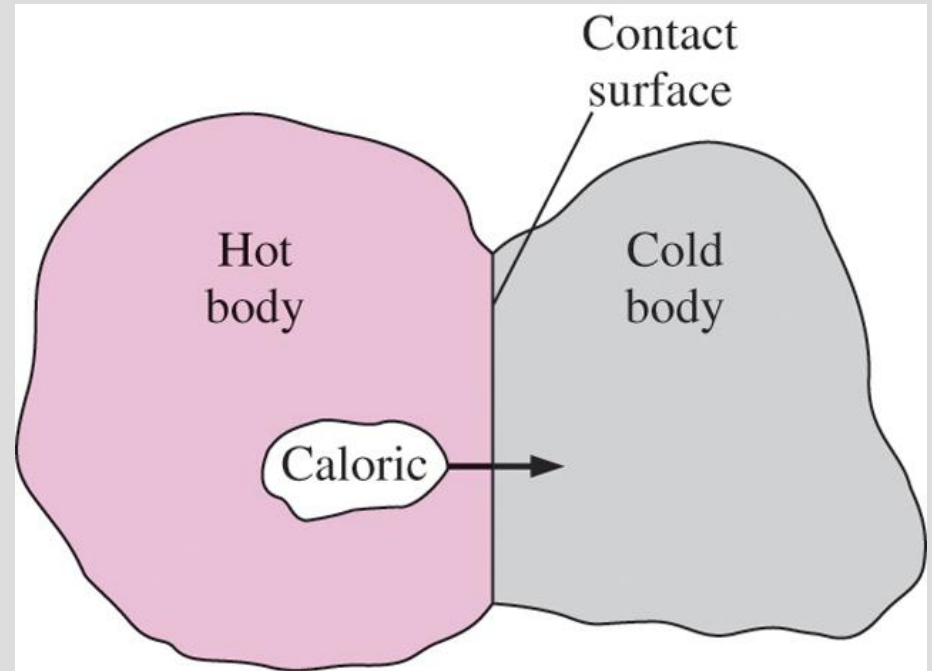

In the early nineteenth century, heat was thought to be an invisible fluid called the **caloric** that flowed from warmer bodies to the cooler ones.

ENERGY TRANSFER BY WORK

- **Work:** The energy transfer associated with a force acting through a distance.
 - ✓ **A rising piston, a rotating shaft, and an electric wire crossing the system boundaries** are all associated with work interactions
- **Formal sign convention:** *Heat transfer to a system and work done by a system are positive; heat transfer from a system and work done on a system are negative.*
- Alternative to sign convention is to use the subscripts **in** and **out** to indicate direction. This is the primary approach in this text.

$$w = \frac{W}{m} \quad (\text{kJ/kg})$$

Work done per unit mass

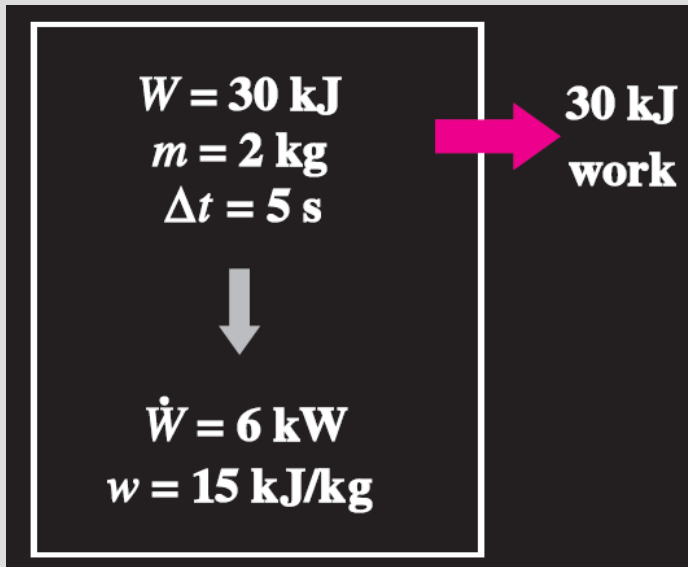

Power is the work done per unit time (kW)

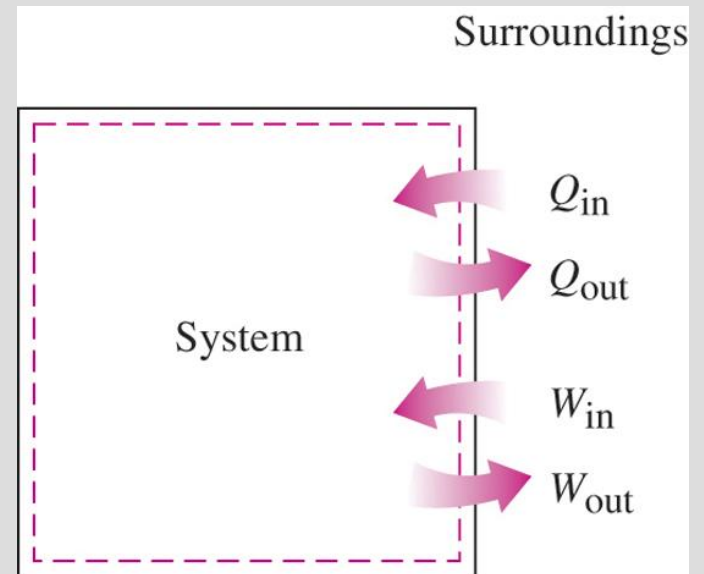

Specifying the directions of heat and work.

Heat vs. Work

- Both are recognized at the boundaries of a system as they cross the boundaries. That is, both heat and work are *boundary* phenomena.
- Systems possess energy, but not heat or work.
- Both are associated with a *process*, not a state.
- Unlike properties, heat or work has no meaning at a state.
- Both are *path functions* (i.e., their magnitudes depend on the path followed during a process as well as the end states).

Properties are point functions have exact differentials (d).

$$\int_1^2 dV = V_2 - V_1 = \Delta V$$

Path functions have inexact differentials (δ)

$$\int_1^2 \delta W = W_{12} \quad (\text{not } \Delta W)$$

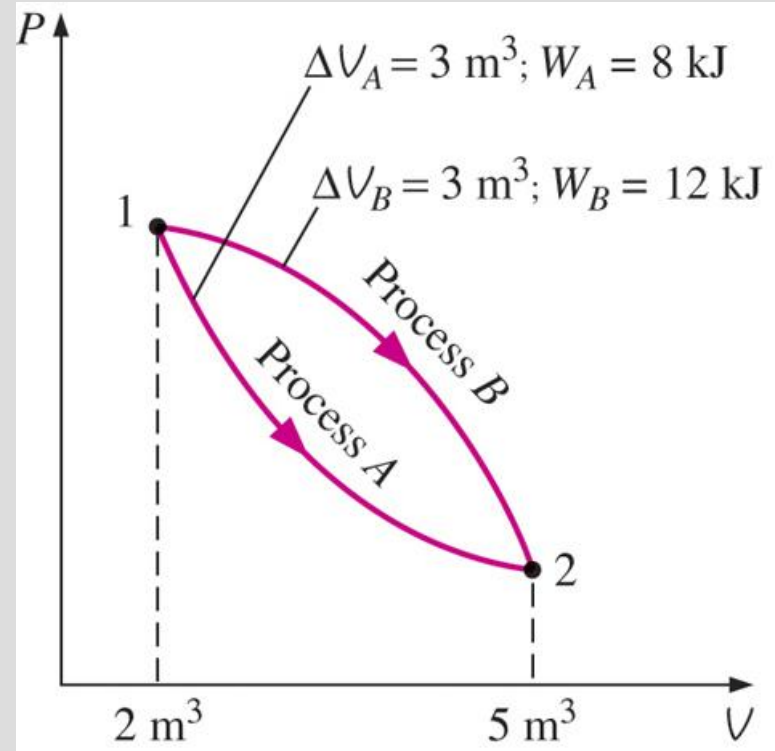

Properties are point functions; but heat and work are path functions (their magnitudes depend on the path followed).

Electrical Work

Electrical work

$$W_e = \mathbf{VN}$$

Electrical power

$$\dot{W}_e = \mathbf{VI} \quad (\text{W})$$

When potential difference and current change with time

$$W_e = \int_1^2 \mathbf{VI} dt \quad (\text{kJ})$$

When potential difference and current remain constant

$$W_e = \mathbf{VI} \Delta t \quad (\text{kJ})$$

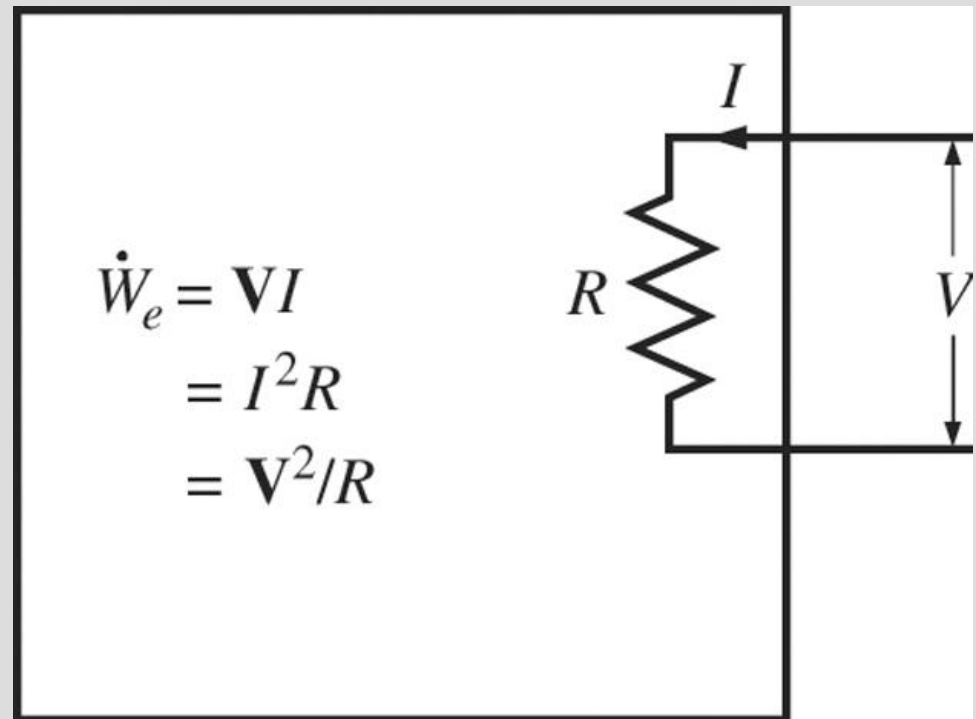

Electrical power in terms of resistance R , current I , and potential difference V .

MECHANICAL FORMS OF WORK

- There are two requirements for a work interaction between a system and its surroundings to exist:
 - ✓ there must be a **force** acting on the boundary.
 - ✓ the boundary must **move**.

Work = Force × Distance

$$W = Fs \quad (\text{kJ})$$

When force is not constant

$$W = \int_1^2 F ds \quad (\text{kJ})$$

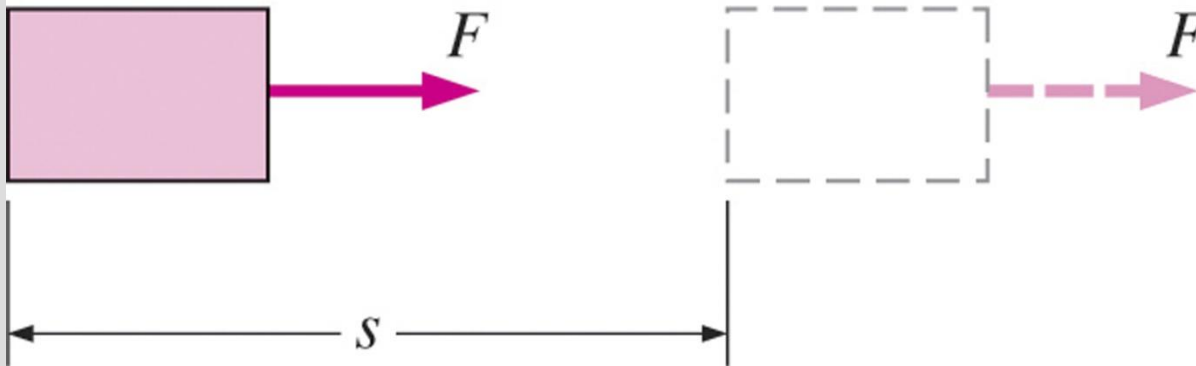

The work done is proportional to the force applied (F) and the distance traveled (s).



If there is no movement, no work is done.

Shaft Work

A force F acting through a moment arm r generates a torque T

$$T = Fr \quad \rightarrow \quad F = \frac{T}{r}$$

This force acts through a distance s $s = (2\pi r)n$

Shaft work

$$W_{\text{sh}} = Fs = \left(\frac{T}{r}\right)(2\pi rn) = 2\pi nT \quad (\text{kJ})$$

The power transmitted through the shaft is the shaft work done per unit time

$$\dot{W}_{\text{sh}} = 2\pi n\dot{T} \quad (\text{kW})$$

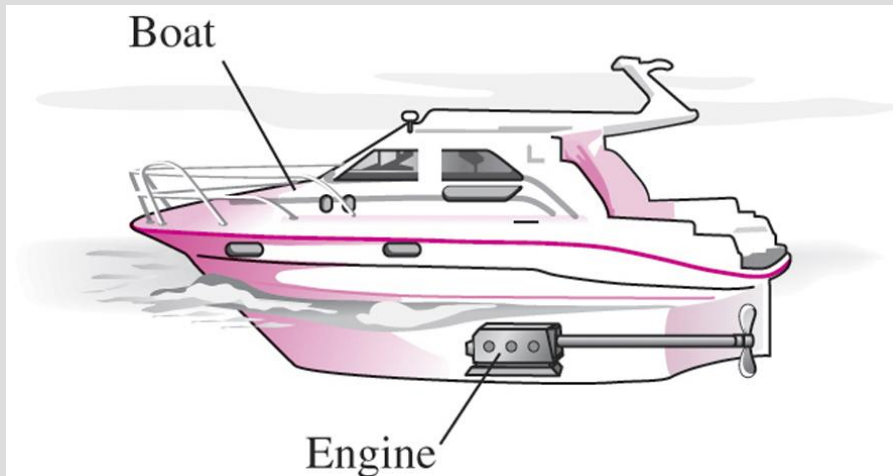

Energy transmission through rotating shafts is commonly encountered in practice.

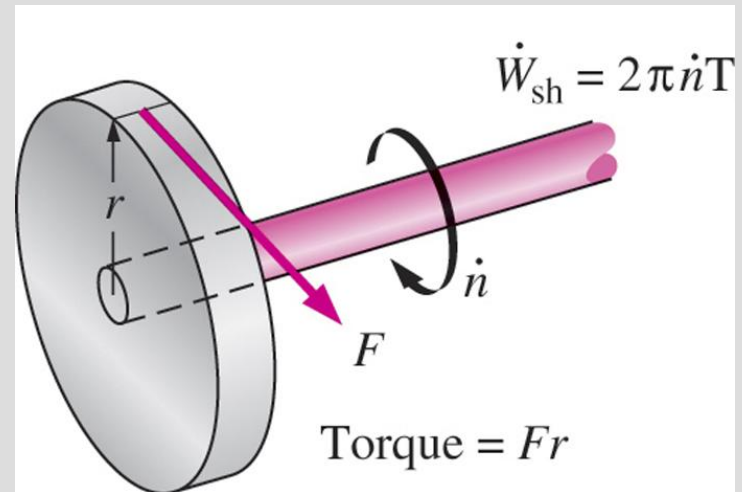

Shaft work is proportional to the torque applied and the number of revolutions of the shaft.

Spring Work

When the length of the spring changes by a differential amount dx under the influence of a force F , the work done is

$$\delta W_{\text{spring}} = F dx$$

For linear elastic springs, the displacement x is proportional to the force applied

$$F = kx \quad (\text{kN}) \quad k: \text{spring constant (kN/m)}$$

Substituting and integrating yield

$$W_{\text{spring}} = \frac{1}{2}k(x_2^2 - x_1^2) \quad (\text{kJ})$$

x_1 and x_2 : the initial and the final displacements

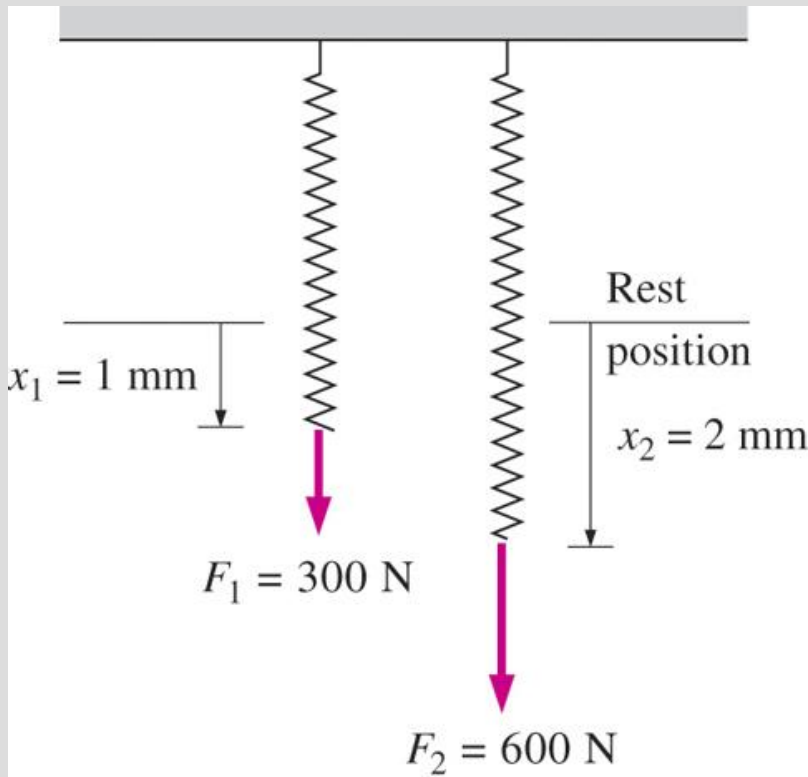

Elongation of a spring under the influence of a force.

The displacement of a linear spring doubles when the force is doubled.

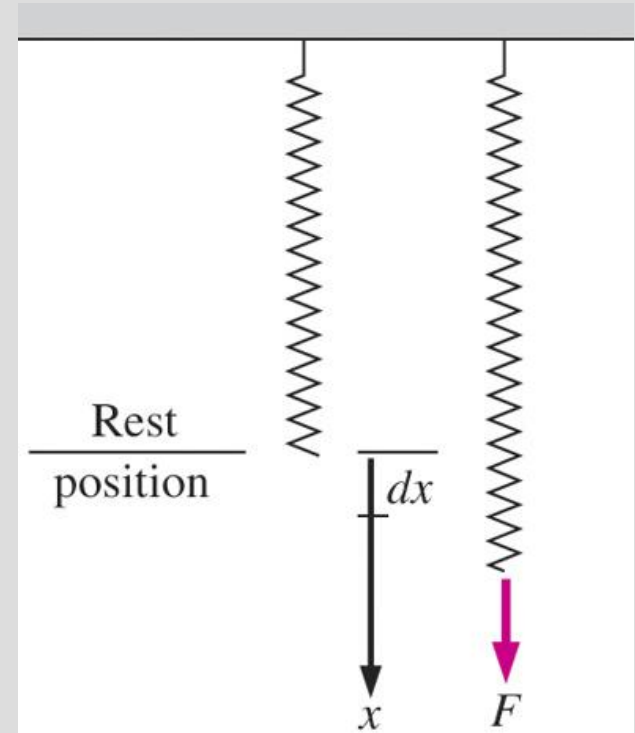

Work Done on Elastic Solid Bars

$$W_{\text{elastic}} = \int_1^2 F dx = \int_1^2 \sigma_n A dx \quad (\text{kJ})$$

Work Associated with the Stretching of a Liquid Film

$$W_{\text{surface}} = \int_1^2 \sigma_s dA \quad (\text{kJ})$$

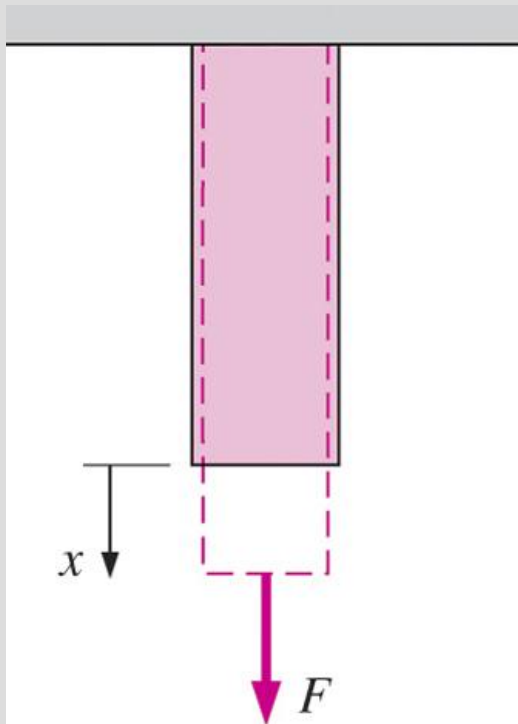

Stretching a liquid film with a movable wire.

Solid bars behave as springs under the influence of a force.

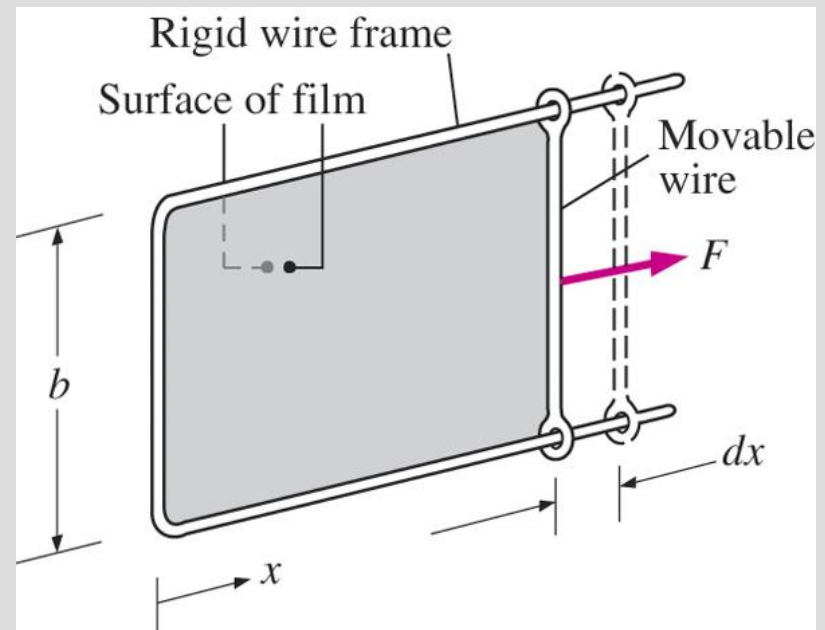

Work Done to Raise or to Accelerate a Body

1. The work transfer needed to raise a body is equal to the change in the potential energy of the body.
2. The work transfer needed to accelerate a body is equal to the change in the kinetic energy of the body.

Nonmechanical Forms of Work

Electrical work: The generalized force is the *voltage* (the electrical potential) and the generalized displacement is the *electrical charge*.

Magnetic work: The generalized force is the *magnetic field strength* and the generalized displacement is the total *magnetic dipole moment*.

Electrical polarization work: The generalized force is the *electric field strength* and the generalized displacement is the *polarization of the medium*.



The energy transferred to a body while being raised is equal to the change in its potential energy.

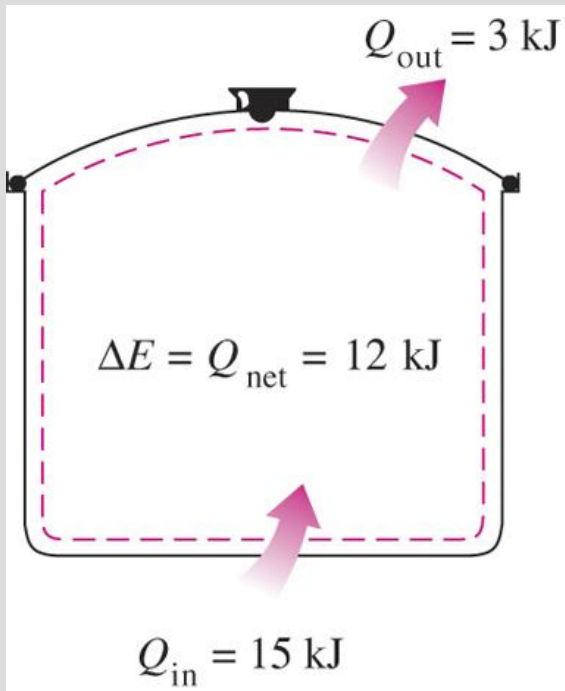

In the absence of any work interactions, the energy change of a system is equal to the net heat transfer.

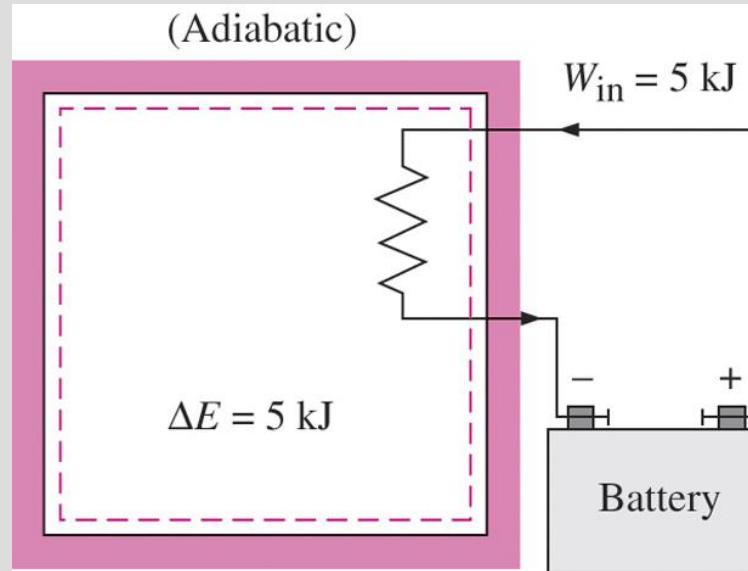

The work (electrical) done on an adiabatic system is equal to the increase in the energy of the system.

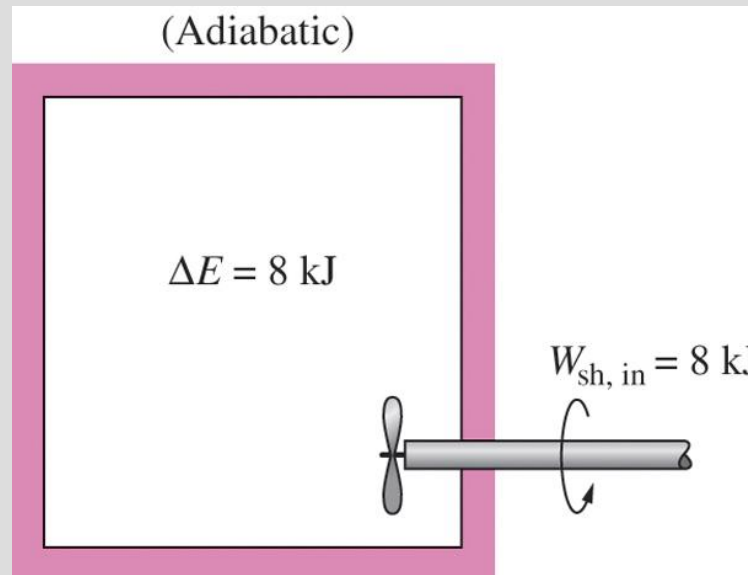

The work (shaft) done on an adiabatic system is equal to the increase in the energy of the system.

Energy Balance

The net change (increase or decrease) in the total energy of the system during a process is equal to the difference between the total energy entering and the total energy leaving the system during that process.

$$\left(\begin{array}{c} \text{Total energy} \\ \text{entering the system} \end{array} \right) - \left(\begin{array}{c} \text{Total energy} \\ \text{leaving the system} \end{array} \right) = \left(\begin{array}{c} \text{Change in the total} \\ \text{energy of the system} \end{array} \right)$$

$$E_{\text{in}} - E_{\text{out}} = \Delta E_{\text{system}}$$

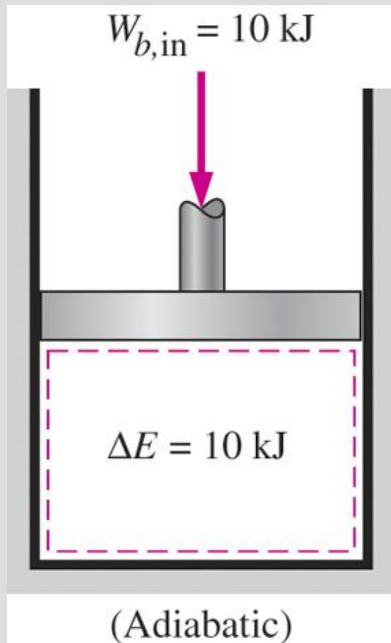

The energy change of a system during a process is equal to the *net* work and heat transfer between the system and its surroundings.

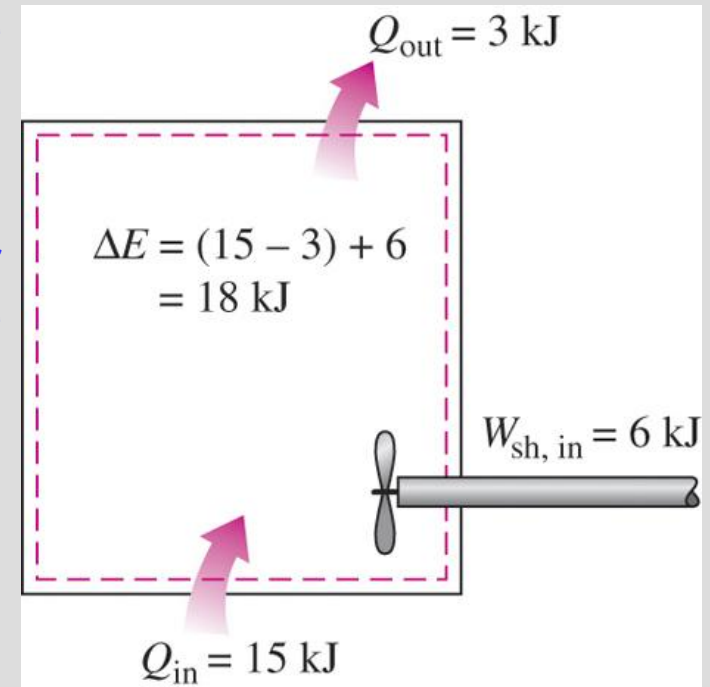

The work (boundary) done on an adiabatic system is equal to the increase in the energy of the system.

Energy Change of a System, ΔE_{system}

Energy change = Energy at final state – Energy at initial state

$$\Delta E_{\text{system}} = E_{\text{final}} - E_{\text{initial}} = E_2 - E_1$$

$$\Delta E = \Delta U + \Delta \text{KE} + \Delta \text{PE}$$

Internal, kinetic, and potential energy changes

$$\Delta U = m(u_2 - u_1)$$

$$\Delta \text{KE} = \frac{1}{2}m(V_2^2 - V_1^2)$$

$$\Delta \text{PE} = mg(z_2 - z_1)$$

Stationary Systems

$$z_1 = z_2 \rightarrow \Delta \text{PE} = 0$$

$$V_1 = V_2 \rightarrow \Delta \text{KE} = 0$$

$$\Delta E = \Delta U$$

Mechanisms of Energy Transfer, E_{in} and E_{out}

- Heat transfer
- Work transfer
- Mass flow

A closed mass involves only *heat transfer* and *work*.

$$E_{in} - E_{out} = (Q_{in} - Q_{out}) + (W_{in} - W_{out}) + (E_{mass,in} - E_{mass,out}) = \Delta E_{system}$$

$$\underbrace{E_{in} - E_{out}}_{\text{Net energy transfer by heat, work, and mass}} = \underbrace{\Delta E_{system}}_{\text{Change in internal, kinetic, potential, etc., energies}} \quad (\text{kJ})$$

$$\underbrace{\dot{E}_{in} - \dot{E}_{out}}_{\text{Rate of net energy transfer by heat, work, and mass}} = \underbrace{dE_{system}/dt}_{\text{Rate of change in internal, kinetic, potential, etc., energies}} \quad (\text{kW})$$

$$Q = \dot{Q} \Delta t \quad (\text{kJ})$$

$$W = \dot{W} \Delta t$$

$$\Delta E = (dE/dt) \Delta t$$

$$e_{in} - e_{out} = \Delta e_{system} \quad (\text{kJ/kg})$$

$$\delta E_{in} - \delta E_{out} = dE_{system} \quad \delta e_{in} - \delta e_{out} = de_{system}$$

$$\dot{W}_{net,out} = \dot{Q}_{net,in} \quad (\text{for a cycle})$$

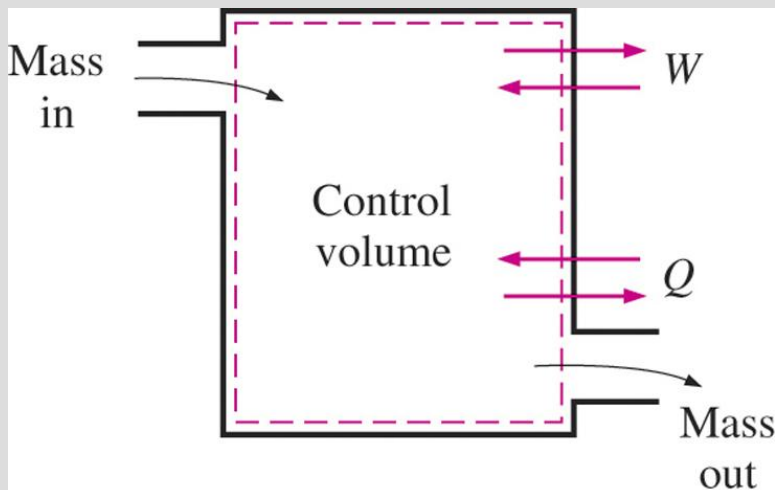

The energy content of a control volume can be changed by mass flow as well as heat and work interactions.

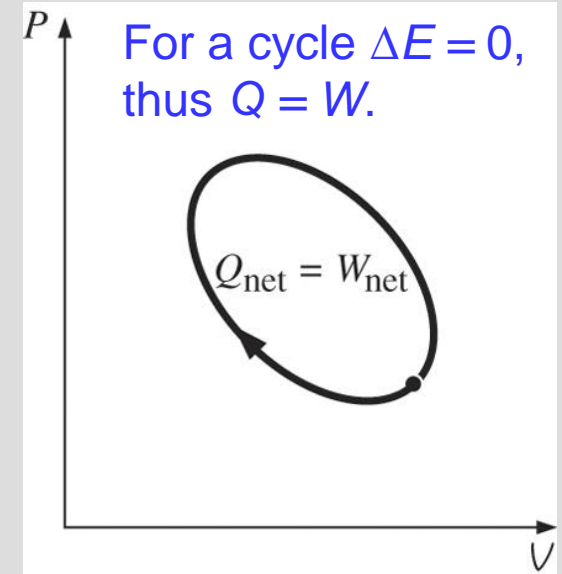

ENERGY CONVERSION EFFICIENCIES

Efficiency is one of the most frequently used terms in thermodynamics, and it indicates how well an energy conversion or transfer process is accomplished.

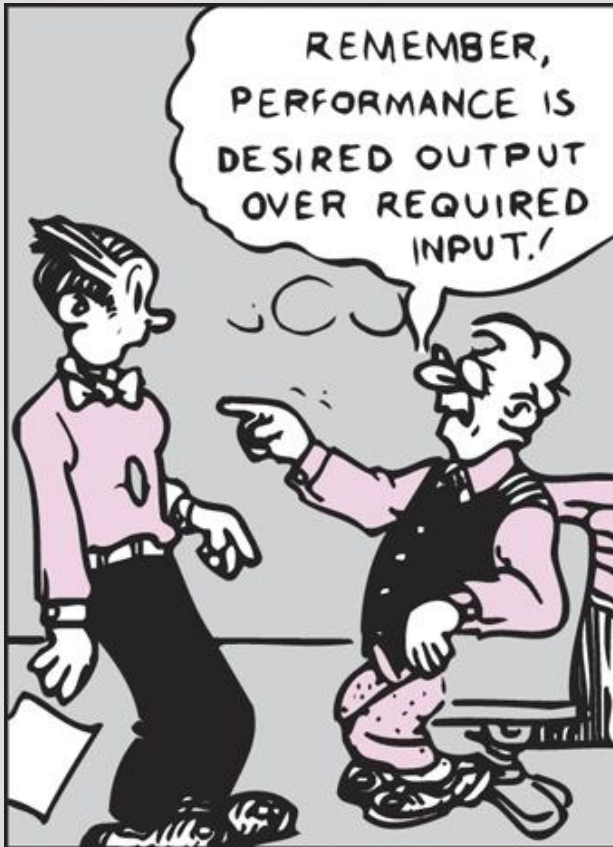

$$\text{Performance} = \frac{\text{Desired output}}{\text{Required input}}$$

Efficiency of a water heater: The ratio of the energy delivered to the house by hot water to the energy supplied to the water heater.

Type	Efficiency
Gas, conventional	55%
Gas, high-efficiency	62%
Electric, conventional	90%
Electric, high-efficiency	94%



The definition of performance is not limited to thermodynamics only.

$$\eta_{\text{combustion}} = \frac{Q}{\text{HV}} = \frac{\text{Amount of heat released during combustion}}{\text{Heating value of the fuel burned}}$$

Heating value of the fuel: The amount of heat released when a unit amount of fuel at room temperature is completely burned and the combustion products are cooled to the room temperature.

Lower heating value (LHV): When the water leaves as a vapor.

Higher heating value (HHV): When the water in the combustion gases is completely condensed and thus the heat of vaporization is also recovered.

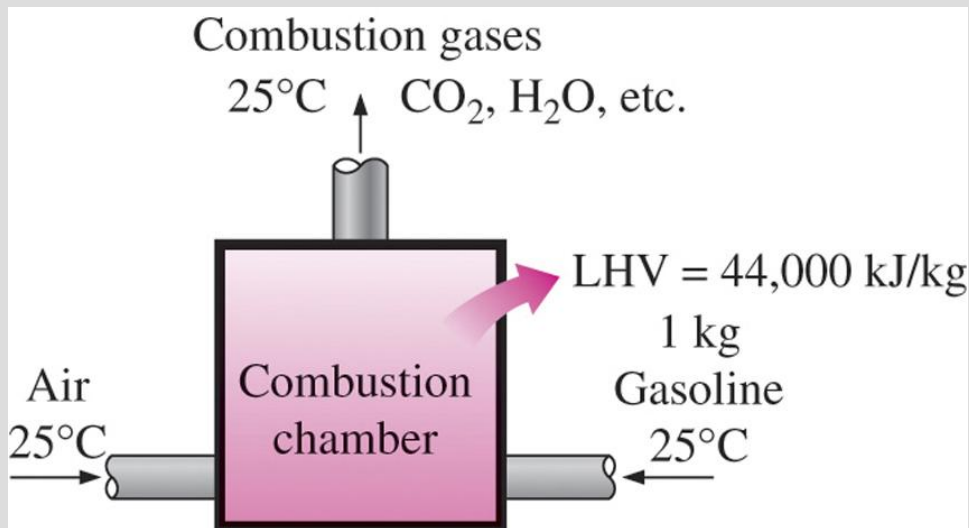

The definition of the heating value of gasoline.

The efficiency of space heating systems of residential and commercial buildings is usually expressed in terms of the **annual fuel utilization efficiency (AFUE)**, which accounts for the combustion efficiency as well as other losses such as heat losses to unheated areas and start-up and cooldown losses.

- **Generator:** A device that converts mechanical energy to electrical energy.
- **Generator efficiency:** The ratio of the electrical power output to the mechanical power input.
- **Thermal efficiency of a power plant:** The ratio of the net electrical power output to the rate of fuel energy input.

$$\eta_{\text{overall}} = \eta_{\text{combustion}} \eta_{\text{thermal}} \eta_{\text{generator}} = \frac{\dot{W}_{\text{net,electric}}}{\text{HHV} \times \dot{m}_{\text{net}}}$$

Overall efficiency of a power plant

The efficacy of different lighting systems

Type of lighting	Efficacy, lumens/W
<i>Combustion</i>	
Candle	0.2
<i>Incandescent</i>	
Ordinary	6–20
Halogen	16–25
<i>Fluorescent</i>	
Ordinary	40–60
High output	70–90
Compact	50–80
<i>High-intensity discharge</i>	
Mercury vapor	50–60
Metal halide	56–125
High-pressure sodium	100–150
Low-pressure sodium	up to 200

Lighting efficacy:

The amount of light output in lumens per W of electricity consumed.

A 15-W compact fluorescent lamp provides as much light as a 60-W incandescent lamp.

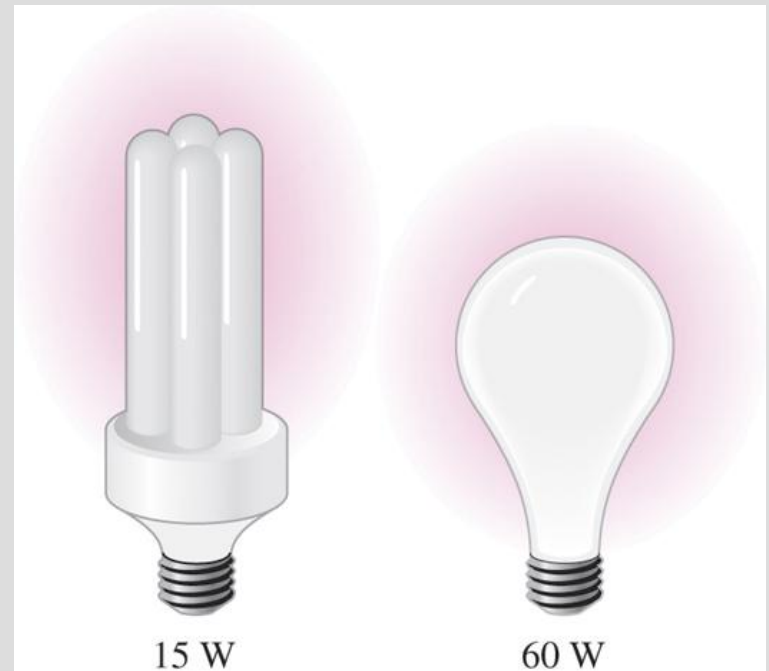

Energy costs of cooking a casserole with different appliances*

[From A. Wilson and J. Morril, *Consumer Guide to Home Energy Savings*, Washington, DC: American Council for an Energy-Efficient Economy, 1996, p. 192.]

Cooking appliance	Cooking temperature	Cooking time	Energy used	Cost of energy
Electric oven	350°F (177°C)	1 h	2.0 kWh	\$0.16
Convection oven (elect.)	325°F (163°C)	45 min	1.39 kWh	\$0.11
Gas oven	350°F (177°C)	1 h	0.112 therm	\$0.07
Frying pan	420°F (216°C)	1 h	0.9 kWh	\$0.07
Toaster oven	425°F (218°C)	50 min	0.95 kWh	\$0.08
Electric slow cooker	200°F (93°C)	7 h	0.7 kWh	\$0.06
Microwave oven	"High"	15 min	0.36 kWh	\$0.03

*Assumes a unit cost of \$0.08/kWh for electricity and \$0.60/therm for gas.

- Using energy-efficient appliances **conserve energy**.
- It helps the **environment** by reducing the amount of pollutants emitted to the atmosphere during the combustion of fuel.
- The combustion of fuel produces
 - **carbon dioxide**, causes global warming
 - **nitrogen oxides** and **hydrocarbons**, cause smog
 - **carbon monoxide**, toxic
 - **sulfur dioxide**, causes acid rain.

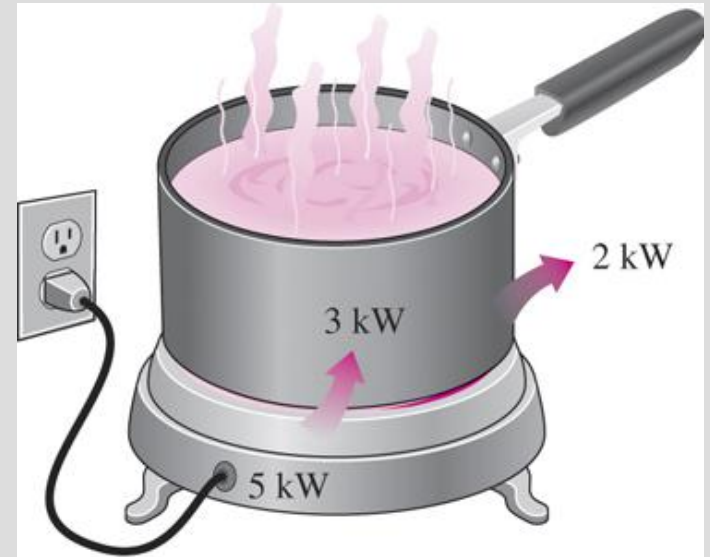

$$\text{Efficiency} = \frac{\text{Energy utilized}}{\text{Energy supplied to appliance}}$$

$$= \frac{3 \text{ kWh}}{5 \text{ kWh}} = 0.60$$

The efficiency of a cooking appliance represents the fraction of the energy supplied to the appliance that is transferred to the food.

Efficiencies of Mechanical and Electrical Devices

Mechanical efficiency

$$\eta_{\text{mech}} = \frac{\text{Mechanical energy output}}{\text{Mechanical energy input}} = \frac{E_{\text{mech,out}}}{E_{\text{mech,in}}} = 1 - \frac{E_{\text{mech,loss}}}{E_{\text{mech,in}}}$$

The effectiveness of the conversion process between the mechanical work supplied or extracted and the mechanical energy of the fluid is expressed by the **pump efficiency** and **turbine efficiency**,

$$\eta_{\text{pump}} = \frac{\text{Mechanical energy increase of the fluid}}{\text{Mechanical energy input}} = \frac{\Delta \dot{E}_{\text{mech,fluid}}}{\dot{W}_{\text{shaft,in}}} = \frac{\dot{W}_{\text{pump,u}}}{\dot{W}_{\text{pump}}}$$

$$\Delta \dot{E}_{\text{mech,fluid}} = \dot{E}_{\text{mech,out}} - \dot{E}_{\text{mech,in}}$$

$$\eta_{\text{turbine}} = \frac{\text{Mechanical energy output}}{\text{Mechanical energy decrease of the fluid}} = \frac{\dot{W}_{\text{shaft,out}}}{|\Delta \dot{E}_{\text{mech,fluid}}|} = \frac{\dot{W}_{\text{turbine}}}{\dot{W}_{\text{turbine,e}}}$$

$$|\Delta \dot{E}_{\text{mech,fluid}}| = \dot{E}_{\text{mech,in}} - \dot{E}_{\text{mech,out}}$$

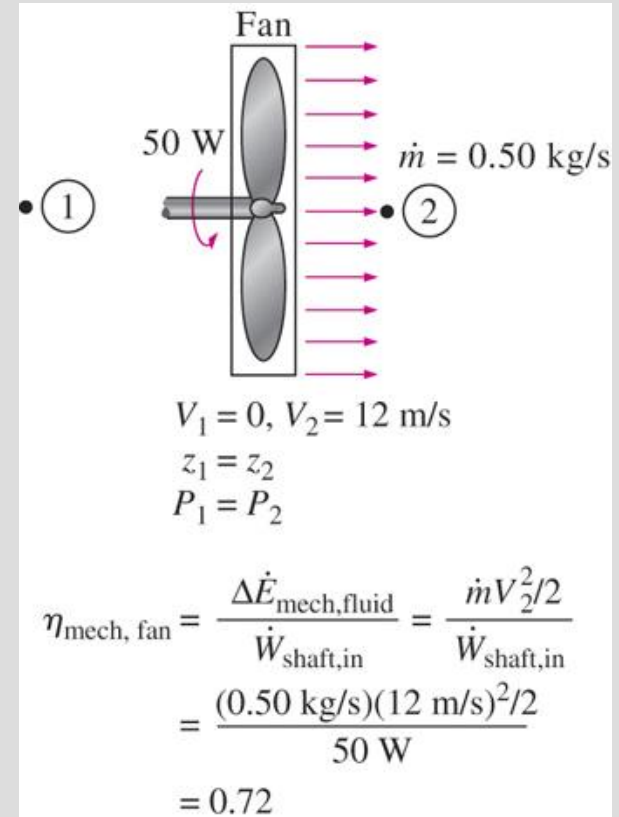

The mechanical efficiency of a fan is the ratio of the kinetic energy of air at the fan exit to the mechanical power input.

$$\eta_{\text{motor}} = \frac{\text{Mechanical power output}}{\text{Electric power input}} = \frac{\dot{W}_{\text{shaft,out}}}{\dot{W}_{\text{elect,in}}}$$

Pump
efficiency

$$\eta_{\text{generator}} = \frac{\text{Electric power output}}{\text{Mechanical power input}} = \frac{\dot{W}_{\text{elect,out}}}{\dot{W}_{\text{shaft,in}}}$$

Generator
efficiency

$$\eta_{\text{pump-motor}} = \eta_{\text{pump}}\eta_{\text{motor}} = \frac{\dot{W}_{\text{pump},u}}{\dot{W}_{\text{elect,in}}} = \frac{\Delta\dot{E}_{\text{mech,fluid}}}{\dot{W}_{\text{elect,in}}}$$

Pump-Motor
overall efficiency

$$\eta_{\text{turbine-gen}} = \eta_{\text{turbine}}\eta_{\text{generator}} = \frac{\dot{W}_{\text{elect,out}}}{\dot{W}_{\text{turbine},e}} = \frac{\dot{W}_{\text{elect,out}}}{|\Delta\dot{E}_{\text{mech,fluid}}|}$$

Turbine-Generator
overall efficiency

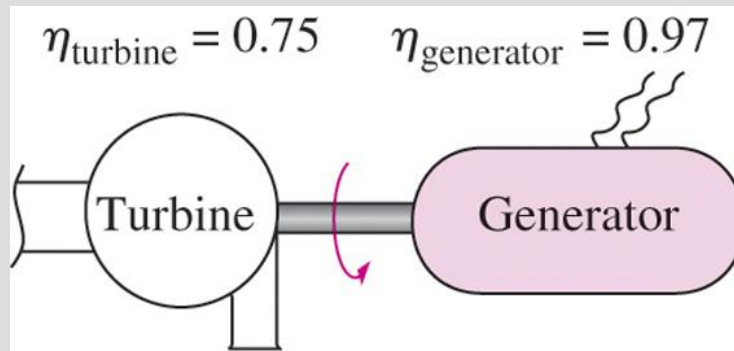

$$\begin{aligned}\eta_{\text{turbine-gen}} &= \eta_{\text{turbine}}\eta_{\text{generator}} \\ &= 0.75 \times 0.97 \\ &= 0.73\end{aligned}$$

The overall efficiency of a turbine-generator is the product of the efficiency of the turbine and the efficiency of the generator, and represents the fraction of the mechanical energy of the fluid converted to electric energy.

ENERGY AND ENVIRONMENT

- The conversion of energy from one form to another often affects the environment and the air we breathe in many ways, and thus the study of energy is not complete without considering its impact on the environment.
- Pollutants emitted during the combustion of fossil fuels are responsible for **smog, acid rain**, and **global warming**.
- The environmental pollution has reached such high levels that it became a serious threat to **vegetation, wild life**, and **human health**.

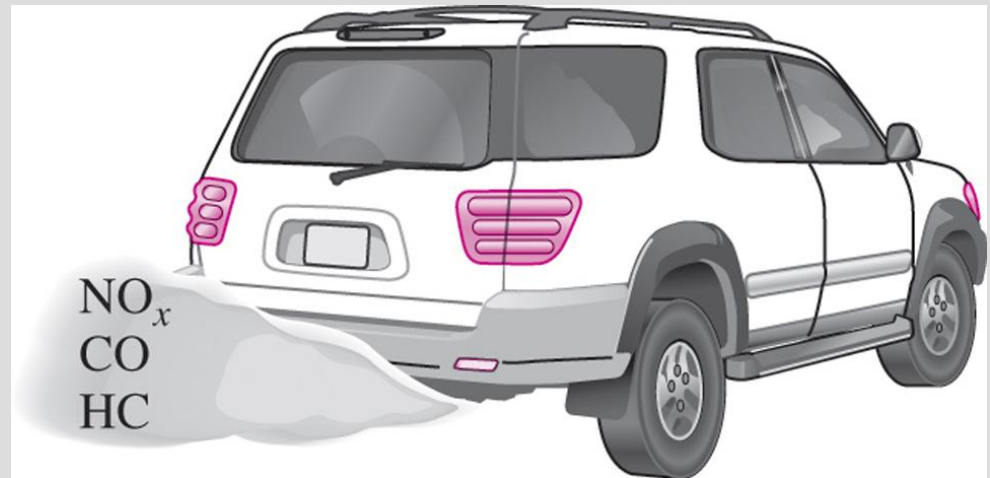

Motor vehicles are the largest source of air pollution.

Energy conversion processes are often accompanied by environmental pollution.

Ozone and Smog

- **Smog:** Made up mostly of ground-level ozone (O_3), but it also contains numerous other chemicals, including carbon monoxide (CO), particulate matter such as soot and dust, volatile organic compounds (VOCs) such as benzene, butane, and other hydrocarbons.
- **Hydrocarbons** and **nitrogen oxides** react in the presence of sunlight on hot calm days to form ground-level ozone.
- **Ozone** irritates eyes and damages the air sacs in the lungs where oxygen and carbon dioxide are exchanged, causing eventual hardening of this soft and spongy tissue.
- It also causes shortness of breath, wheezing, fatigue, headaches, and nausea, and aggravates respiratory problems such as asthma.

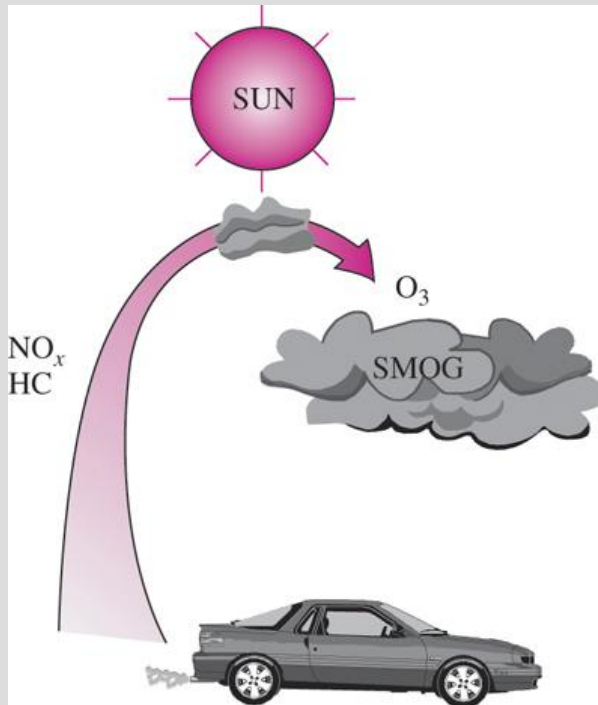

- The other serious pollutant in smog is **carbon monoxide**, which is a colorless, odorless, poisonous gas.
- It is mostly emitted by motor vehicles.
- It deprives the body's organs from getting enough oxygen by binding with the red blood cells that would otherwise carry oxygen. It is fatal at high levels.
- Suspended **particulate matter** such as **dust** and **soot** are emitted by vehicles and industrial facilities. Such particles irritate the eyes and the lungs.

Ground-level ozone, which is the primary component of smog, forms when HC and NO_x react in the presence of sunlight in hot calm days.

Acid Rain

- The sulfur in the fuel reacts with oxygen to form sulfur dioxide (SO_2), which is an air pollutant.
- The main source of SO_2 is the electric power plants that burn high-sulfur coal.
- Motor vehicles also contribute to SO_2 emissions since gasoline and diesel fuel also contain small amounts of sulfur.

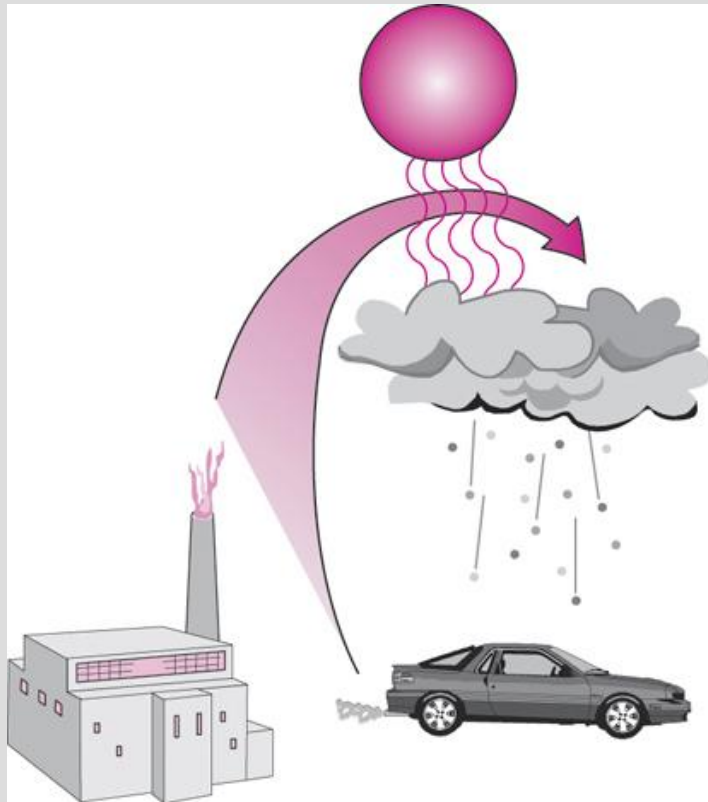

- The sulfur oxides and nitric oxides react with water vapor and other chemicals high in the atmosphere in the presence of sunlight to form sulfuric and nitric acids.
- The acids formed usually dissolve in the suspended water droplets in clouds or fog.
- These acid-laden droplets, which can be as acidic as lemon juice, are washed from the air on to the soil by rain or snow. This is known as **acid rain**.

Sulfuric acid and **nitric acid** are formed when sulfur oxides and nitric oxides react with water vapor and other chemicals high in the atmosphere in the presence of sunlight.

The Greenhouse Effect: Global Warming

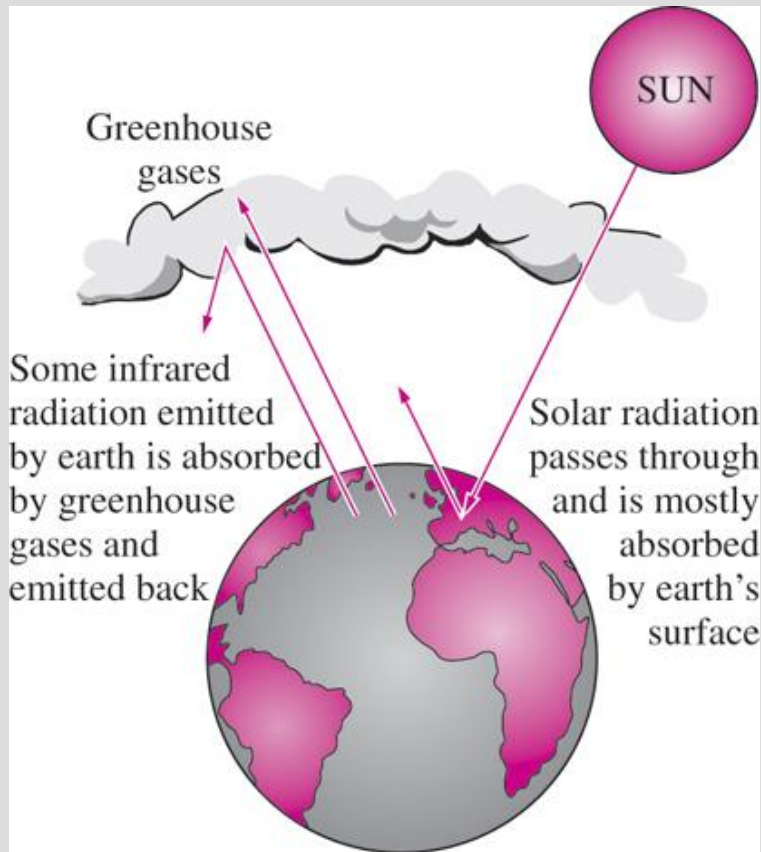

The greenhouse effect on earth.

- **Greenhouse effect:** Glass allows the solar radiation to enter freely but blocks the infrared radiation emitted by the interior surfaces. This causes a rise in the interior temperature as a result of the thermal energy buildup in a space (i.e., car).
- The surface of the earth, which warms up during the day as a result of the absorption of solar energy, cools down at night by radiating part of its energy into deep space as infrared radiation.
- **Carbon dioxide (CO₂),** water vapor, and trace amounts of some other gases such as methane and nitrogen oxides act like a blanket and keep the earth warm at night by blocking the heat radiated from the earth. The result is **global warming**.
- These gases are called “**greenhouse gases**,” with CO₂ being the primary component.
- CO₂ is produced by the burning of fossil fuels such as **coal, oil, and natural gas**.

THE FIRST LAW OF THERMODYNAMICS

- The *first law of thermodynamics (the conservation of energy principle)* provides a sound basis for studying the relationships among the various forms of energy and energy interactions.
- The first law states that *energy can be neither created nor destroyed during a process; it can only change forms.*
- **The First Law:** For all adiabatic processes between two specified states of a closed system, the net work done is the same regardless of the nature of the closed system and the details of the process.

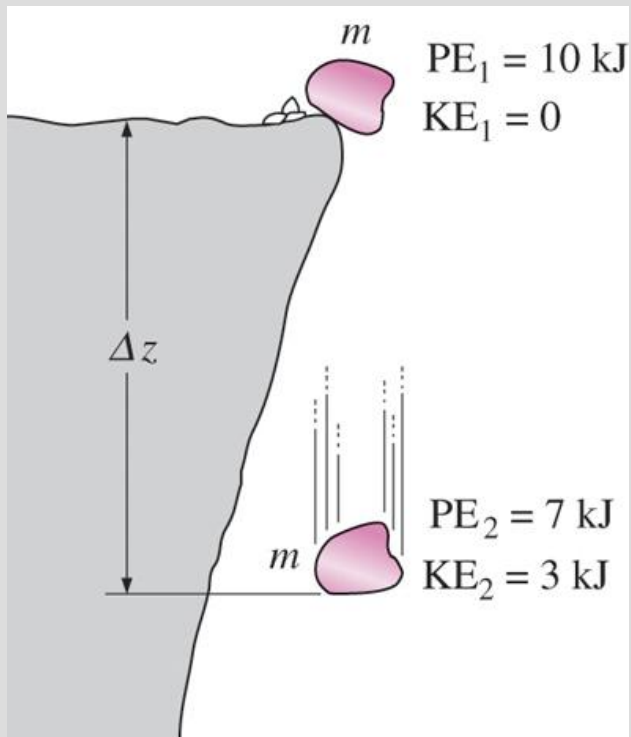

Energy cannot be created or destroyed; it can only change forms.

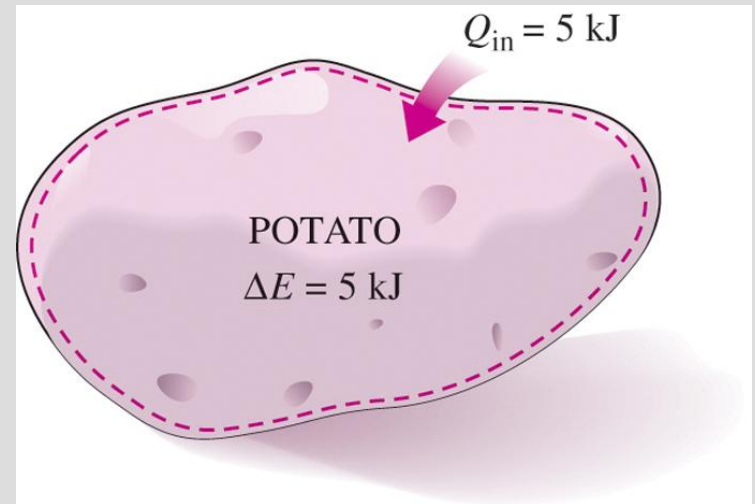

The increase in the energy of a potato in an oven is equal to the amount of heat transferred to it.

General Energy Equation

- Recall general RTT

$$\frac{dB_{sys}}{dt} = \frac{d}{dt} \int_{CV} \rho b dV + \int_{CS} \rho b (\vec{V}_r \cdot \vec{n}) dA$$

- “Derive” energy equation using $B=E$ and $b=e$

$$\frac{dE_{sys}}{dt} = \dot{Q}_{net,in} + \dot{W}_{net,in} = \frac{d}{dt} \int_{CV} \rho e dV + \int_{CS} \rho e (\vec{V}_r \cdot \vec{n}) dA$$

- Break power into rate of shaft and pressure work

$$\dot{W}_{net,in} = \dot{W}_{shaft,net,in} + \dot{W}_{pressure,net,in} = \dot{W}_{shaft,net,in} - \int P (\vec{V} \cdot \vec{n}) dA$$

General Energy Equation

- Moving integral for rate of pressure work to RHS of energy equation results in:

$$Q_{net,in} + W_{shaft,net,in} = \frac{d}{dt} \int_{CV} \rho e d\dot{V} + \int_{CS} \left(\frac{P}{\rho} + e \right) e (\vec{V}_r \cdot \vec{n}) dA$$

- Recall that P/ρ is the **flow work**, which is the work associated with pushing a fluid into or out of a CV per unit mass.

General Energy Equation

- As with the mass equation, practical analysis is often facilitated as averages across inlets and exits

$$Q_{net,in} + W_{shaft,net,in} = \frac{d}{dt} \int_{CV} \rho e d\dot{V} + \sum_{out} \dot{m} \left(\frac{P}{\rho} + e \right) - \sum_{in} \dot{m} \left(\frac{P}{\rho} + e \right)$$

$$\dot{m} = \int_{A_c} \rho (\vec{V} \cdot \vec{n}) dA_c$$

- Since $e = u + ke + pe = u + V^2/2 + gz$

$$Q_{net,in} + W_{shaft,net,in} = \frac{d}{dt} \int_{CV} \rho e d\dot{V} + \sum_{out} \dot{m} \left(\frac{P}{\rho} + u + \frac{V^2}{2} + gz \right) - \sum_{in} \dot{m} \left(\frac{P}{\rho} + u + \frac{V^2}{2} + gz \right)$$